



R60-16 R60-18 R60-20

Elektro Gabelstapler
Electric Fork Truck
Chariot élévateur électrique
Carretilla elevadora electrica

STILL
ELECTRONIC
DOCUMENTATION
SYSTEM

STEDS



**Werk-
statt-
handbuch**

**Work-
shop
manual**

**Manuel
d'Atelier**

**Manual
de taller**

R6030-R6032 R6050 - R6052
R6033i - R6035i R6053i -R6055i

Ident-Nr.164522 (en)



STILLGmbH

Information relating to workshop manual

The workshop manual is valid for all of the listed trucks.

This workshop manual has been prepared for the truck types 6030 - 6032.

For newer truck types, supplements will be provided in case of deviations. The supplements will include valid truck types.

designation	design	truck typ							
		DC current				AC current			
R60-16	Swing axle	6030	6050			6033	6053		
R60-18	Swing axle	6031	6051			6034	6054		
R60-20	Swing axle	6032	6052			6035	6055		

Chassis and counterweight

Chassis and counterweight

The chassis is a welded construction.

Chassis and counterweight are connected together with 4 hexagon bolts M20x70 8.8.

Bolt tightening torque: 385 Nm

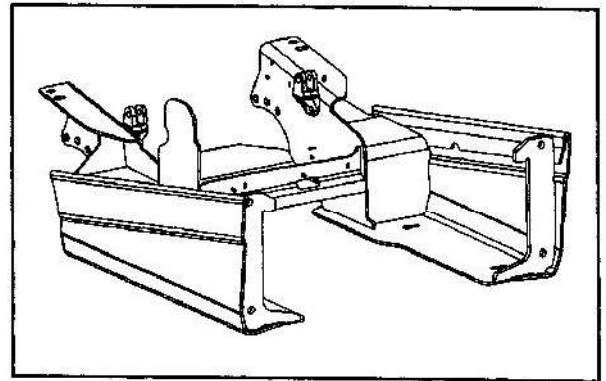

Weights of counterweights:

6030/31/33/34 → 818 kg

6050/51/53/54

6032/35, 6052/55 → 936 kg

Battery compartment dimensions

	6030/33 6050/53	6031/34 6051/54	6032/35 6052/55
A	788 ±3	788 ±3	788 ±3
B	1040 ±2	1040 ±2	1040 ±2
C	580 ±3	580 ±3	580 ±3

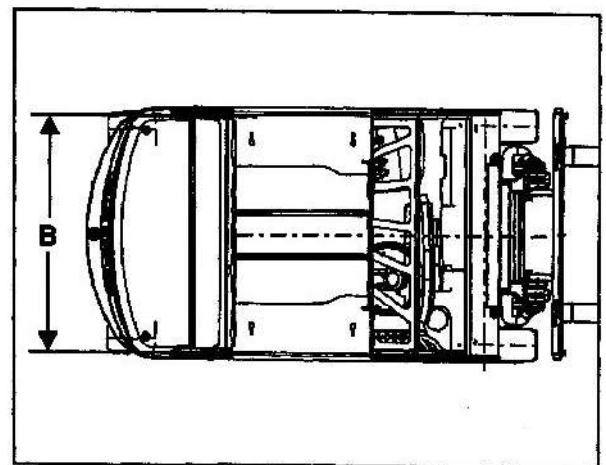
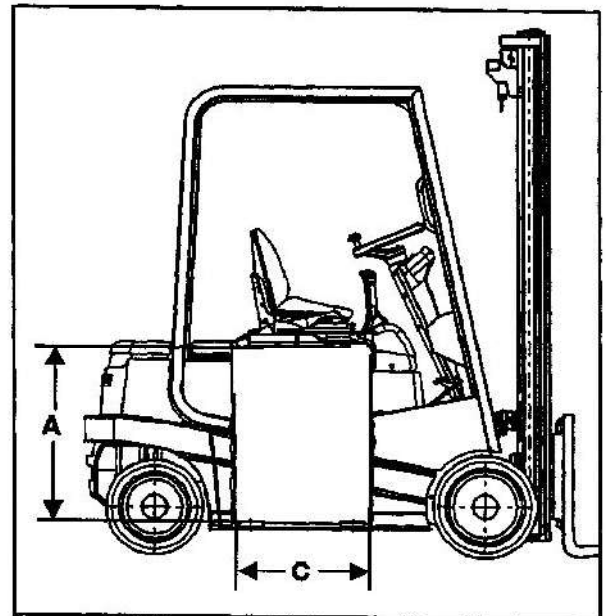

Thanks for your reading.

Please click here to download complete manual instantly.

And can also choose other manuals.

Feel free --->write to me with any questions.

Our service email:

manuals007@hotmail.com