

WORKSHOP SERVICE MANUAL

CONTENTS

- 1 - Introduction - Specifications
- 2 - Splitting the tractor
- 3 - Engine and equipment
- 4 - Clutch
- 5 - Gearbox
- 6 - Rear axle
- 7 - Power Take Off
- 8 - Front axle 2 and 4WD
- 9 - Hydraulics
- 10 - Electrical equipment
- 11 - Electronics
- 12 - Cab and Equipment
- 13 - Accessories
- 14 - Service Tools



1 . INTRODUCTION

Contents

1 A01 INTRODUCTION



Introduction

1 A01 Introduction

CONTENTS

A.	Reading the manual _____	2
B.	General specifications _____	3
C.	Chassis mounting points and dimensions _____	13
D.	Safety precautions _____	16
E.	Practical advice _____	17
F.	Installation instructions _____	21
G.	Conversion tables _____	22
H.	Locking compounds and sealants _____	30
I.	Tightening torques _____	30



1A01.2



Introduction

A. Reading the manual

General

The aim of this manual is to assist Distributors and Dealers in the efficient installation, maintenance and repair of MASSEY FERGUSON machinery. These operations can be carried out within the times specified in the repair times schedule by following the procedures specified and using appropriate specialised tools.

Page numbering

Example: 6 B03.2

This manual is divided into sections and parts. Each page is identified with the following information:

- 6 = Section
- B = Part
- 03 = Sequence number within the part
- 2 = Page number within the part

The issue number and the date are shown at the bottom of the page.

Using the manual

To make information easier to find, there is an index at the beginning of each section listing the various parts in that section.

At the beginning of each part there is a table of contents which should also be used as a guide to locate information.

Items are indicated by means of identifying symbols (circles, squares, triangles).

Meaning of identifying symbols

Circle ○ (...): identifies component part only.

Square □ [...]: identifies component part and indicates an adjustment.

Triangle ▲ /...: identifies component part and indicates an important point to be noted during assembly and disassembly.

Amendments

Amended pages are issued with the same page numbers as the previous pages: only the issue number and the date are changed.

The old pages must be destroyed.

Service tools

When a special service tool must be used in an operation, the tool number is specified along with the instruction requiring its use.

Repairs and replacements

When parts have to be replaced, it is essential that only genuine MASSEY FERGUSON parts should be used. Special attention should be paid to the following points concerning repairs and the fitting of replacement parts and accessories.

Safety features embodied in the tractor could be impaired if genuine parts are not fitted.

In certain countries, legislation prohibits the fitting of parts that fail to comply with tractor manufacturer's specifications. The torque wrench setting figures specified in the workshop manual must be strictly complied with. Locking devices must be installed where specified. If the efficiency of a locking device is impaired during removal, a new one must be fitted.

The tractor warranty is invalidated if parts other than genuine MASSEY FERGUSON parts are fitted. All MASSEY FERGUSON replacement parts benefit from the full backing of the manufacturer's warranty. MASSEY FERGUSON Distributors and Dealers are required to supply only genuine parts.

Repair time schedule

The sections on repair times are identical to those in the workshop manual. This repair time schedule is available under publication number 3378047M1.

**Introduction****B. General specifications****Engine**

Characteristic	8110	8120	8130	8140	8150	8160
MF manufactured by VALMET	-	-	-	620 DS	620 DS	634 DS
PERKINS model	1006.6THR2	1006.6THR3	1006.6THR4	-	-	-
Number of cylinders	6	6	6	6	6	6
Turbocharger	yes	yes	yes	yes	yes	yes
Bore (mm)	100	100	100	108	108	108
Stroke (mm)	127	127	127	120	120	134
Cubic capacity (cm ³)	6000	6000	6000	6600	6600	7400
Maximum power DIN (KW)	99.3	106.6	114	117.7	132,4	147,1
P.T.O. power (KW)	88.3	97	103	106.6	117,6	132.3
At engine speed of rev/min	2200	2200	2200	2200	2200	2200
Maximum torque (Nm)	551	588	625	650	720	810
Engine speed at maximum torque (rev/min)	1400	1400	1400	1300	1400	1300
Idling speed (rev/min)	1000	1000	1000	1000	1000	1000
Torque at rated speed (Nm)	430	462	495	555	555	620
Maximum no load speed (rev/min)	2310	2310	2310	2370	2370	2370
Permissible front P.T.O. (KW) at 2200 rev/min	75	75	75		92,1	
Maximum torque (Nm)	328	328	328		400	
Lubrication	Gear type pump-strainer on suction and external canister type filters					
Valves	Overhead, push-rod operated					
Valve clearances (cold)						
- Inlet (mm-in)	0,20 / 0,08	0,20 / 0,08	0,20 / 0,08	0,35 / 0,012	0,35 / 0,012	0,35 / 0,012
- Exhaust (mm-in)	0,45 / 0,018	0,45 / 0,018	0,45 / 0,018	0,35 / 0,012	0,35 / 0,012	0,35 / 0,012
Engine oil cooler	yes	yes	yes	yes	yes	yes

Fuel system and air cleaner

Supply pump	AC DELCO	Bosch in line
Fuel filter	Yes	
Number of elements	2	
Fuel injection pump	Stanadyne	Bosch in line
Injectors and nozzle holders	Stanadyne	
Cold weather starting	Thermostart	
Air cleaner : Two stage, dry element with blockage indicator. Built-in centrifugal pre-filter, self-cleaning by exhaust extraction of dust		



1A01.4

Introduction

Electrical system

Voltage :	12 volts negative earth.
Batteries :	2 maintenance free batteries
Safety start :	operated by the clutch pedal.
Bulbs:	
headlights :	European code 40 / 45 W
sidelights :	5 W
rear/brake lights :	21/5 W
direction indicators :	21 W
number plate light :	10 W
work lamps :	55 W - H3
instrument panel lighting and warning lights :	3W - 2 W - 1.2 W
roof light :	10 W

Cooling

Operation :	centrifugal pump pressurised radiator, regulated by pressure cap. Opening temperature : 83 ° C (181,4° F)
controlled by thermostat.	
Fan :	Viscostatic model.
Belt driven :	centrifugal water pump.
Belt deflection :	- with belt tension gauge : 355 N - without gauge : 10 mm (3/8") (on the longest span)

Transmission

Wet clutch 230 mm ø (9.05 in)	6 discs (8110/8120/8130) 7 discs (8140/8150) 8 discs (8160)
Gearbox :	
Dynashift Gearbox :	- 32 front speeds - 32 rear speeds - Four selectable ratios without declutching - Reverse shuttle (synchronised)



Final reduction units

Reduction units:	epicyclic, in the rear axle housings.
Reduction ratios :	• 8110/8120/8130/8140 : ND 5.571:1 • 8110/8120/8130/8140 : HD 6.214:1 Sealed compartment 8140 - (8130 - option) • 8150/8160 (8140 - option) composite final drive 7.141:1

**Introduction**

Road speeds "DYNASHIFT" at 2200 rev/min

Front

Ratio	With 20.8 - 38 tyres				With 20.8 - 42 tyres					
	8110/8120		8130		8140		8150/8160			
	KPh	MPh	KPh	MPh	KPh	MPh	KPh	MPh		
	1	A	2.156	1.34	2.125	1.32	2.538	1.58	2.522	1.57
		B	2.524	1.57	2.487	1.54	2.971	1.85	2.952	1.84
		C	2.979	1.85	2.936	1.82	3.507	2.18	3.485	2.17
		D	3.486	2.17	3.437	2.14	4.105	2.55	4.079	2.54
	2	A	3.272	2.03	3.225	2.01	3.852	2.39	3.828	2.38
		B	3.830	2.38	3.775	2.35	4.509	2.80	4.480	2.79
		C	4.521	2.81	4.456	2.80	5.382	3.35	5.288	3.29
		D	5.291	3.29	5.215	3.24	6.229	3.87	6.190	3.85
	3	A	4.675	2.90	4.608	2.86	5.503	3.42	5.469	3.40
		B	5.471	3.40	5.393	3.35	6.441	4.00	6.400	3.98
		C	6.458	4.02	6.366	3.96	7.603	4.73	7.555	4.70
		D	7.559	4.70	7.451	4.63	8.899	5.53	8.843	5.50
	4	A	6.363	3.95	6.272	4.00	7.491	4.66	7.443	4.63
		B	7.447	4.63	7.340	4.56	8.767	5.45	8.712	5.42
		C	8.790	5.46	8.664	5.40	10.348	6.43	10.283	6.40
		D	10.288	6.40	10.141	6.30	12.112	7.5	12.036	7.49
	1	A	8.385	5.21	8.265	5.13	8.362	5.19	8.309	5.16
		B	9.814	6.09	9.673	5.76	9.787	6.08	9.725	5.76
		C	11.584	7.19	11.418	7.09	11.552	7.17	11.479	7.13
		D	13.558	8.42	13.364	8.30	13.521	8.40	13.435	8.34
	2	A	12.725	7.90	12.543	7.79	12.690	7.88	12.610	7.83
		B	14.894	9.25	14.681	9.12	14.852	9.23	14.759	9.17
		C	17.580	10.92	17.329	10.77	17.532	10.89	17.421	10.82
		D	20.577	12.78	20.282	12.60	20.520	12.75	20.390	12.67
	3	A	18.179	11.29	17.919	11.13	18.128	11.26	18.014	11.19
		B	21.277	13.22	20.972	13.03	21.218	13.18	21.084	13.10
		C	25.115	15.60	24.755	15.38	25.045	15.56	24.087	14.97
		D	29.395	18.26	28.975	18.00	29.314	18.21	29.129	18.10
	4	A	24.743	15.37	24.389	15.15	24.675	15.33	24.519	15.23
		B	28.960	17.99	28.546	17.74	28.880	17.84	28.697	17.83
		C	34.184	21.24	33.695	20.94	34.089	21.18	33.874	21.05
		D	40.010	24.86	39.438	24.51	39.900	24.79	39.648	24.64



1A01.6

8100 SERIES TRACTORS

**Introduction**

Road speeds "DYNASHIFT" at 2200 rev/min

Rear

Ratio	With 20.8 - 38 tyres				With 20.8 - 42 tyres					
	8110/8120		8130		8140		8150/8160			
	KPh	MPh	KPh	MPh	KPh	MPh	KPh	MPh		
	1	A	1.985	1.23	1.957	1.22	2.487	1.55	2.322	1.44
		B	2.323	1.44	2.290	1.42	2.910	1.81	2.718	1.60
		C	2.742	1.71	2.703	1.68	3.435	2.14	3.208	1.20
		D	3.210	2.00	3.164	1.97	4.021	2.50	3.755	2.34
	2	A	3.012	1.87	2.969	1.85	3.774	2.35	3.524	2.19
		B	3.526	2.19	3.475	2.16	4.417	2.75	4.125	2.57
		C	4.162	2.59	4.102	2.55	5.213	3.24	4.869	3.03
		D	4.871	3.03	4.802	2.99	6.102	3.80	5.699	3.54
	3	A	4.304	2.68	4.242	2.64	5.391	3.35	5.035	3.13
		B	5.037	3.13	4.965	3.09	6.310	3.92	5.892	3.66
		C	5.945	3.70	5.860	3.64	7.448	4.63	6.955	4.33
		D	6.959	4.33	6.859	4.27	8.717	5.42	8.141	5.06
	4	A	5.858	3.64	5.774	3.59	7.338	4.56	6.853	4.26
		B	6.856	4.26	6.758	4.20	8.588	5.34	8.020	4.99
		C	8.092	5.03	7.977	4.96	10.137	6.30	9.467	5.88
		D	9.472	5.89	9.336	5.81	11.865	7.38	11.081	6.89
	1	A	7.719	4.79	7.609	4.72	8.191	5.09	7.649	4.75
		B	9.035	5.61	8.906	5.53	9.587	5.95	8.953	5.56
		C	10.664	6.62	10.512	6.53	11.316	7.03	10.568	6.56
		D	12.482	7.75	12.304	7.64	13.245	8.23	12.369	7.68
	2	A	11.715	7.28	11.548	7.17	12.431	7.72	11.609	7.21
		B	13.712	8.52	13.516	8.40	14.549	9.04	13.587	8.44
		C	16.185	10.05	15.953	9.91	17.174	10.67	16.038	9.96
		D	18.944	11.77	18.673	11.60	20.101	12.49	18.772	11.66
	3	A	16.736	10.40	16.497	10.25	17.758	11.03	16.584	10.30
		B	19.588	12.17	19.308	12.00	20.785	12.91	19.410	12.06
		C	23.121	14.36	22.791	14.16	24.534	15.24	22.912	14.23
		D	27.062	16.81	26.675	16.57	28.715	17.84	26.817	16.66
	4	A	22.780	14.15	22.454	13.95	24.171	15.02	22.573	14.02
		B	26.662	16.57	26.280	16.33	23.290	14.47	26.420	16.42
		C	31.471	19.55	31.021	19.27	33.393	20.75	31.185	19.38
		D	36.835	22.89	36.308	22.56	39.085	24.29	36.501	22.68



Introduction

Power take-off

P.T.O. ratio

Proportional to the engine speed. Hydraulic clutch.

540 rev/min at 1990 engine rev/min

750 rev/min at 2000 engine rev/min

1000 rev/min at 2090 engine rev/min

Speed changing

By changing shaft

- 540 rev/min shaft, 35 mm (1 3/8 in) diameter 6 splines

- 1000 rev/min shaft, 35 mm (1 3/8 in) diameter 21 spline

For 8160 : One speed only

1000 rev/min at 2090 engine rev/min

Front power take-off (optional extra)

Control

Hydraulic clutch mechanism controlled by a button in the cab.

Ratio

1000 rev/min at 2040 engine rev/min

Shaft

35 mm (1 3/8 in) diameter - 21 splines.

Four wheel drive front axle

Clutch mechanism

Hydraulic, electrically actuated by push button in the cab.

Differential lock

Electrically-controlled simultaneous front and rear differential lock

Hydraulics

According to countries and option, two different hydraulic systems are proposed :

1. Closed centre system with flow and pressure control :

Charge circuit :

Max. flow 160 l/mn(35.18 imp.gal - 42.27 US gal) supplies :

- constant boost pressure of 5 bar to the variable displacement pump - lubrication of the gearbox and the PTO clutch - cooling system- top up of the master cylinders.

High-pressure system :

Max. flow 110 l/mn (24.19 imp.gal - 29.05 US gal) at 2200 rev/min and 180 bar, maxi pressure 200 bar supplies :

- steering - trailer brake - 17-bar valve - spool valves - ELC valve

Filtration :

1 strainer, 150 micron, on suction, located to the left of the transmission housing.

External main high-pressure filter, 15 micron, to the right of the housing.

2. Open centre

Two-stage gear pump, driven directly by the engine :

1st stage : This circuit supplies 21 l/mn (4.6 Imp. gal/mn) (5.5 US Gal/mn) at maximum engine speed. Maximum pressure 17 bar.

Hare/Tortoise range gear - Dynashift - Differential lock - P.T.O. -

Front P.T.O. (if fitted) - Four wheel drive (if fitted)

2nd stage : This circuit supplies 54 l/mn (11.2 Imp. gal/mn) (14.2 US gal/mn) at maximum engine speed. Maximum pressure 185 bar.

Hydrostatic steering - Trailer brake system - Auxiliary hydraulic system - Hydraulic lift.

Filtration

External 20 micron throwaway, canister type filter.



1A01.8

8100 SERIES TRACTORS

**Introduction****Hydraulic lift**

Type : 3 point, category 2 or 3 with ball, hinged or hook-type ends.

Rams : Twin externally mounted rams

MF 8110/8120/8130/8140/8150 - Rams Ø 80 mm (3.1 in) or 89 mm (3.5 in)**MF 8160 ***

Position of lift rods on lower links		Length of lift rods		Rams diameter 80 mm (3.1 in)				Rams diameter 89 mm (3.5 in)			
				Lower links				Lower links			
				horizontal		fully raised		horizontal		fully raised	
mm	in	mm	in	kg	Lb	kg	Lb	kg	Lb	kg	Lb
530	(20.86)	675	(26.57)	5056	11158	6485	14312	6360	14036	8157	18002
		*		-	-	6917	15266	-	-	8701	19203
		865	(34.05)	5203	11483	5612	12385	6545	14445	7060	15581
		*		5183	11439	5904	13030	6520	14389	7426	16389
581	(22.87)	675	(26.57)	-	-	6953	15345	-	-	8747	18863
		*		-	-	7374	16947	-	-	9275	20470
		865	(34.05)	5621	12921	5997	13235	7070	15603	7544	16649
		*		5577	12308	6287	13875	7015	15482	7908	17453

Brakes

Type

Oil-immersed single disc per wheel, 343 mm (13.5 in) diameter.

Operation

Hydraulic from two master cylinders, automatic adjustment servo assisted factory fitted

Handbrake

Operates on the rear axle pinion

Trailer brake

According to model.

Differential lock - Rear axle

Type

Coupler

Control

Hydraulic with electrical control

Steering

Type : hydrostatic, fixed or tiltable telescopic steering column, one double action central ram.

Theoretical turning circle *	8110/8120/8130		8140		8150/8160
Tyres	11.0-16	16.9-28	11.0-16	16.9-30	16.9-30
- 2 WD	•		•		
- 4 WD		•		•	•
Track adjustment - m (in)		1,97 (77.6)	1,62 (63.8)	2,17 (85.4)	2,17 (85.4)
Angle available	55°	55°	55°	51°	49°
Radius					
- without braking - m (in)	4,26 (167.7)	4,95 (195)*	4,45 (176)	5,45 (215)*	5,56 (219)*

* with 4WD disengaged



Introduction

Wheels

FRONT	2 wheel drive pressed steel
	4 wheel drive pressed steel 6 or 8 clamps
REAR	pressed steel with manual adjustment
	adjust variable track (6 or 8 rails)
	cast with manual adjustment.

Tyres

Compatibility of front/rear tyres of 4 wheel drive tractors same make and model

Tyres	Front	Rear	Front	Rear	Front	Rear
	11.2-24	16.9-34	13.6-28	18.4-34	16.9-30	26.5-34
	12.4-24	18.4-30		18.4-38		18.4-42
		13.6-38	14.9-28	18.4-32		20.8-42
	13.6-24	18.4-30		24.5-32	12.4-32	18.4-38
		15.5-38		18.4-38		18.4-42
	11.2-28	18.4-30		20.8-38	18.4-34	18.4-30
		15.5-38	16.9-28	20.8-38		15.5-38
	12.4-28	18.4-30		18.4-42		
		23.1-30				

Note : The data in this table is not binding. Ask your dealer for further information on other possible choices.

Water Ballasting (75° fill)

Front tyres	Litre	Imp. gal	US gal	Front tyres	Litre	Imp. gal	US gal
10.0-16	50	11	13	18.4-38	370	81.4	96.2
11.0-16	95	20.9	24.7	20.8-38	460	101.3	121.4
14L-16.1	105	23.1	27.3	20.8-42	510	112.3	134.6
13.6-28	160	35.2	41.6				
14.9-28	190	71.8	49.4				
16.9-28	250	55	65				
16.9-30	260	57.2	68.6				



1A01.10

Introduction

Capacities

Fuel tank : :	8110/8120/8130	: 226 l	(49.7 Imp. gal)	(58.8 US gal)
.....	8140/8150/8160	: 330 l	(72.6 Imp. gal)	(85.8 US gal)
Cooling system :	8110/8120/8130	: 28.5 l	(6.3 Imp. gal)	(7.4 US gal)
.....	8140/8150/8160	: 34 l	(7.5 Imp. gal)	(8.8 US gal)
Engine sump :	8110/8120/8130	: 15.6 l	(3.4 Imp. gal)	(4.0 US gal)
.....	8140/8150/8160	: 19 l	(4.2 Imp. gal)	(4.9 US gal)
Transmission/rear axle :*	8110/8120/8130/8140/8150/8160	: 87.5 l	(19.3 Imp. gal)	(23.2 US gal)
Front axle assembly :	8110/8120/8130/8140	: 10.9 l	(2.4 Imp. gal)	(2.9 US gal)
.....	8150/8160	: 11.7 l	(2.6 Imp. gal)	(3.09 US gal)
Front final reduction units (each) :	8110/8120/8130/8140	: 1.8 l	(0.4 Imp. gal)	(0.47US gal)
.....	8150/8160	: 1.9 l	(0.4 Imp. gal)	(0.5 US gal)
Rear final reduction units (each) :	8140/8120/8130/8140/8150	: 3.6 l	(0.8 Imp. gal)	(0.9 US gal)
Double reduction (each)	8110/8120/8130/8140/8150	: 3.6 l	(0.8 Imp. gal)	(0.9 US gal)
.....	8160	: 4.5 l	(1 Imp. gal)	(1.2 US gal)

* When working on steep slopes 15 l (3.3 Imp. gal.) (4.05 US gal.) of oil can be added.



Introduction

1A01.11

Dimensions and weights - mm (in) - Kg (lb)

	8110/8120/8130		8140		8150		8160	
	2WD	4WD	2WD	4WD	2WD	4WD	2WD	4WD
A. Wheelbase	2777 (110)	2763 (109)	2940 (115.7)	2925 (114.9)	2940 (115.7)	2925 (114.9)	2940 (115.7)	2925 (114.9)
B. Overall length with lower links	4642 (183.8)	4644 (183)	5105 (201)	5039 (198.4)	5105 (201)	5039 (198.4)	5105 (201)	5039 (198.4)
C. Height to roof (cab tractor)	2942 (115.9)	2942 (115.9)	2930 (115.3)	3013 (118.6)	2930 (115.3)	3013 (118.6)	2930 (115.3)	3013 (118.6)
D. Overall width (1)	2771 (109.1)	2832 (111.5)	2771 (109.1)	2832 (111.5)	2852 (112.3)	2852 (112.3)	2832 (111.5)	2832 (111.5)
E. Ground clearance (under drawbar frame)	385 (15.15)	385 (15.15)	550 (21.6)	550 (21.6)	550 (21.6)	550 (21.6)	510 (20)	510 (20)
F. Height to steering wheel (platform models)	2204 (86.8)	2204 (86.8)	2204 (86.8)	2204 (86.8)				
- Total weight (with full tank, without extra weight)		6285 (13856)		6285 (13856)				
Front wheel	11.0-16	14.9-28*	11.0-16	16.9-28	11.0-16	16.9-28	11.0-16	16.9-28
Rear wheel	18.4-38*	20.8-38*	20.8-38*	20.8-38*	20.8-38*	20.8-38*	20.8-38*	20.8-38*

	Rear axle		Front axle	
			AG155	AG200
G. Normal Duty axle housing Ø 82		1909 (75.2)		
Heavy Duty axle housing sealed compartment Ø 82		1960 (77.2)	1920 (75.6)	1920 (75.6)
Heavy Duty axle housing Ø 82		1940 (76.4)		
Heavy Duty axle housing sealed compartment/composite final drive. Ø 95		1940 (76.4)		
H. Stud distance	Diam. 82 shaft	203,70 (8.02)	Diam. 95 shaft	325 (12.8)
L. Centring diameter		149,35 (5.87)		280,80 (11.04)
I. Stud length :	- Wheel with steel hub	41 (1.6)		55 (2.2)
	- Wheel with cast iron hub	66 (2.6)		47 (1.85)
J. Stud diameter		M 18 x 1.5		M18 x 1.5
K. Number of studs		8		8
				M22 x 1.5 10

(1) These dimensions are for a tractor fitted with maxi track setting
* with PAVT wheels

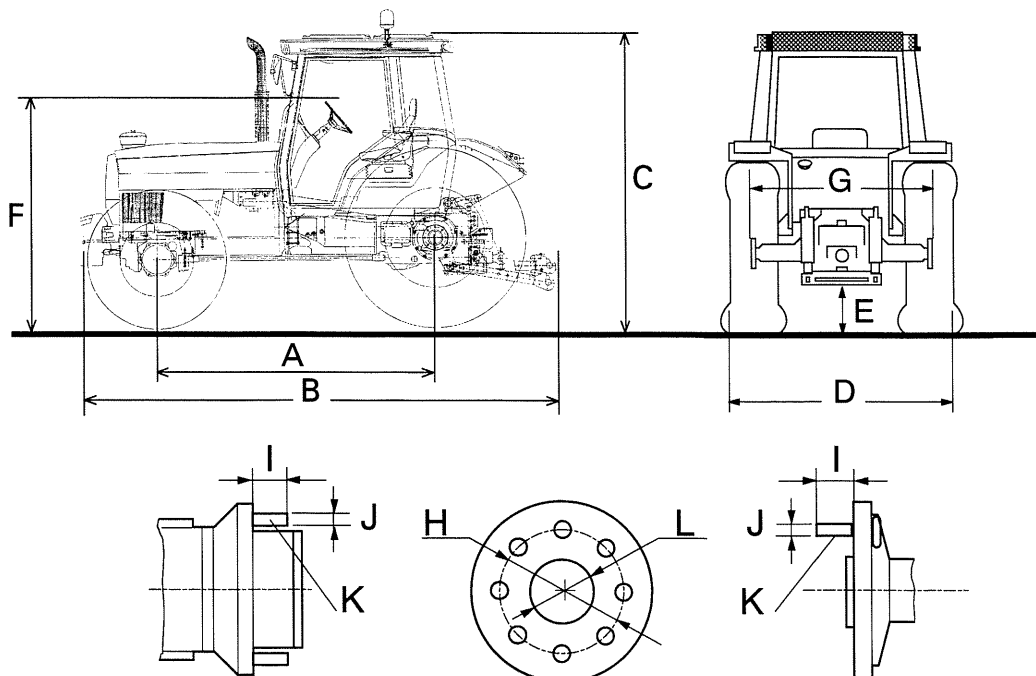



1A01.12

8100 SERIES TRACTORS



Introduction

Static load per axle (kg) at a pressure of 1,5 bar

	Front		Rear	
	Tyres	Charge	Pneus	Charge
2 wheel drive	10.00 - 16	2380 (5254)	18.4 - 38	6420 (14172)
	11.00 - 16	2640 (5828)	20.8 - 38	7810 (17241)
	14L - 16.1	2320 (5121)		
4 wheel drive	13.6 - 28	3320 (7329)	20.8 - 42	7400 (16335)
	14.9 - 28	3850 (8499)	650/75 R34	8140 (17969)
	16.9 - 28	4800 (10596)	710/75 R34	9100 (20088)
	16.9 - 30	4920 (10861)		

Front load limit Kg (lb) (for tractor without front linkage)

	A (Fig. 1)			
	m (in)	1 (39.37)	2 (78.74)	3 (118.11)
8110/20/30/40		945 (2085)	600 (1324)	470 (1037)
8150/8160		1500 (3310)	1060 (2339)	800 (1765)

B = 2 m (78.74 in) maxi

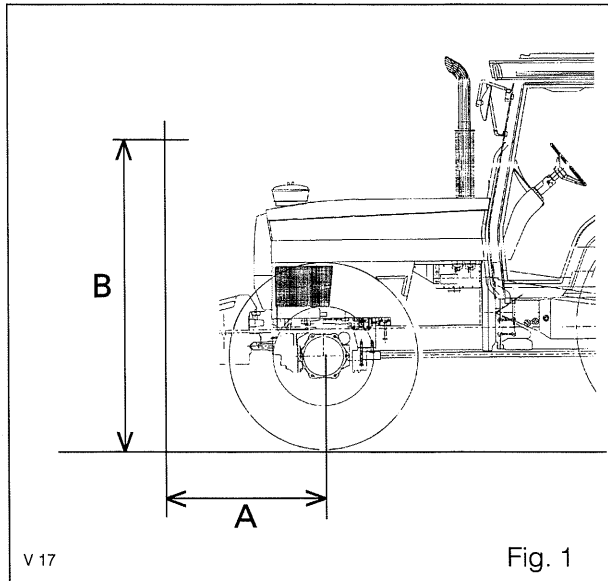



Introduction

C. Chassis mounting points and dimensions

1. Mounting points

Hole N°	Machining		8110 to 8140			8150 - 8160			
			Coordinates			Coordinates			
	Ø	Tapping depth	X	Y	Z	X	Y	Z	
1	M20	38	-1633.8	79.25	±190.5	-2067.8	4.3	±220	
2	M20	38	-1633.8	-15.97	±190.5	-2067.8	-95.7	±220	
3	M20	38	-1392.9	-20	±254	-1929.8	6.35	±254	
4	M20	38	-1392.9	-81.6	±254	-1929.8	-95.25	±254	
5	M20	38	-922.7	6.35	±254	-1869.48	-50.8	±254	
6	M20	38	-922.7	-95.25	±254	-1828.2	-95.25	±254	
7	M20	38	-862.38	-50.8	±254	-1828.2	6.35	±254	
8	M20	38	-821.1	-95.25	±254	-1594.4	-81.6	±254	
9	M20	38	-821.1	6.35	±254	-1594.4	-20	±254	
10	M20	38	-	-	-	-1124.2	6.35	±254	
11	M20	38	-	-	-	-1124.2	-95.25	±254	
12	M20	38	-	-	-	-1063.88	-50.8	±254	
13	M20	38	-	-	-	-1022.6	-95.25	±254	
14	M20	38	-	-	-	-1022.6	6.35	±254	
15	M16	32	121	77	±270	80	77	±270	
16	M16	32	121	-24.6	±270	80	-24.6	±270	
17	M16	32	222.6	77	±270	181.6	77	±270	
18	M16	32	222.6	-24.6	±270	181.6	-24.6	±270	
19	3/4-10	through	317.77	-45	±215.9	276.77	-45	±215.9	
20	3/4-10	30	317.77	-203.2	±215.9	276.77	-203.2	±215.9	
21	3/4-10	30	524.14	-63.5	±215.9	483.14	-63.5	±215.9	
22	3/4-10	30	524.14	-203.2	±215.9	483.14	-203.2	±215.9	
23	3/4-10	30	701.9	-203.2	±215.9	660.9	-203.2	±215.9	
24	3/4-10	30	701.9	-63.5	±215.9	660.9	-63.5	±215.9	
25	20.7	through	1518	-262.8	±632.7	1477	-262.8	±632.7	8150
25	20.7	through	-	-	-	1477	-262.8	±739.6	8160
26	20.7	through	1518	-262.8	±556.5	1477	-262.8	±556.5	8150
26	20.7	through	-	-	-	1477	-262.8	±663.4	8160
27	20.7	through	1759.35	-262.8	±632.7	1718.35	-262.8	±632.7	8150
27	20.7	through	-	-	-	1718.35	-262.8	±739.6	8160
28	20.7	through	1759.35	-262.8	±556.5	1718.35	-262.8	±556.5	8150
28	20.7	through	-	-	-	1718.35	-262.8	±663.4	8160
29	3/4-10	30	2065.98	-151	±149	2024.98	-151	±149	
30	3/4-10	30	2065.98	-363	±153	2024.98	-363	±153	
31	3/4-10	30	2065.98	-264	±75	2024.98	-264	±75	
32	3/4-10	30	2065.98	-363	±57	2024.98	-363	±57	
33	5/8-11	24	2065.98	-146	±53.44	2024.98	-146	±53.44	



1A01.14

Introduction**2. Chassis dimensions**

Dimens.	8110 to 8140	Dim.	8150	8160
34	337.11	34	337.11	337.11
35	354.6	35	354.6	354.6
36	862.3	-	-	-
37	771.5	37	973	973
38	41	-	-	-
39	234.10	39	234.10	234.10
40	823.90	40	823.90	823.90
41	967	41	967	967
42	3699.8	42	4092.8	4092.8
43	539.75	43	539.75	539.75
44	185.41	44	185.41	185.41
45	139.80	45	139.80	139.80
46	168.15	46	168.15	168.15
47	263.65	47	263.65	263.65
48	76.20	48	76.20	76.20
49	203.20	49	203.20	203.20
50	300	50	300	300
51	224	51	224	224
-	-	52	736.8	736.8
-	-	53	358	358
54	444.62	54	444.62	444.62
55	1909 (Normal Duty) 82 dia. shaft	-	-	-
55	1941 (Heavy Duty) 82 dia. shaft	-	-	-
55	1962 (Heavy Duty) sealed reduction unit	55	1962	-
-	double reduction unit	55	-	1940
56	double reduction unit	56	2493	2493
56	2355 sealed reduction unit	-	-	-
-	double reduction unit	57	2991	2991
57	2997 sealed reduction unit	-	-	-
58	233	58	233	233
59	47	59	47	47
60	204.21	60	204.21	204.21
61	2098	61	2046	2046
62	1920	62	1920	1920
63	ø 280.8 - 280.6	-	-	-
64	ø 335	64	ø 335	ø 335
65	ø 149.35 (82 dia. shaft)	-	-	-
65	ø 220.65 (95 dia. shaft)	65	ø 220.65	ø 220.65
66	ø 203.20 (82 dia. shaft)	-	-	-
66	ø 275.25 (95 dia. shaft)	66	ø 275.25	ø 275.25
67	337.11	67	337.11	337.11



Introduction

MF 8110 - 20 - 30 - 40

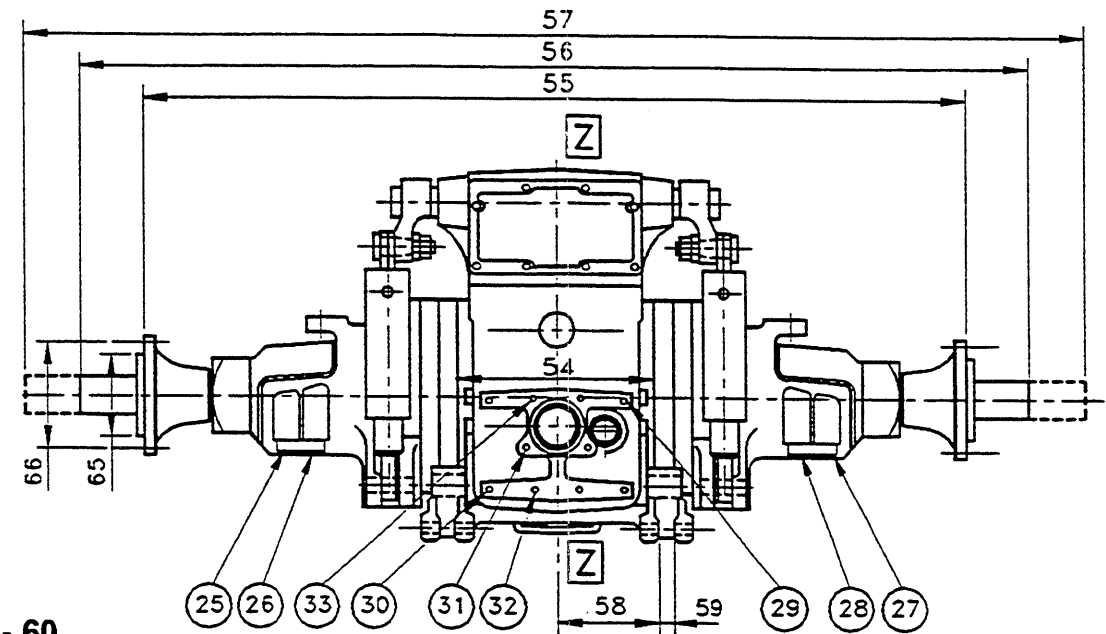
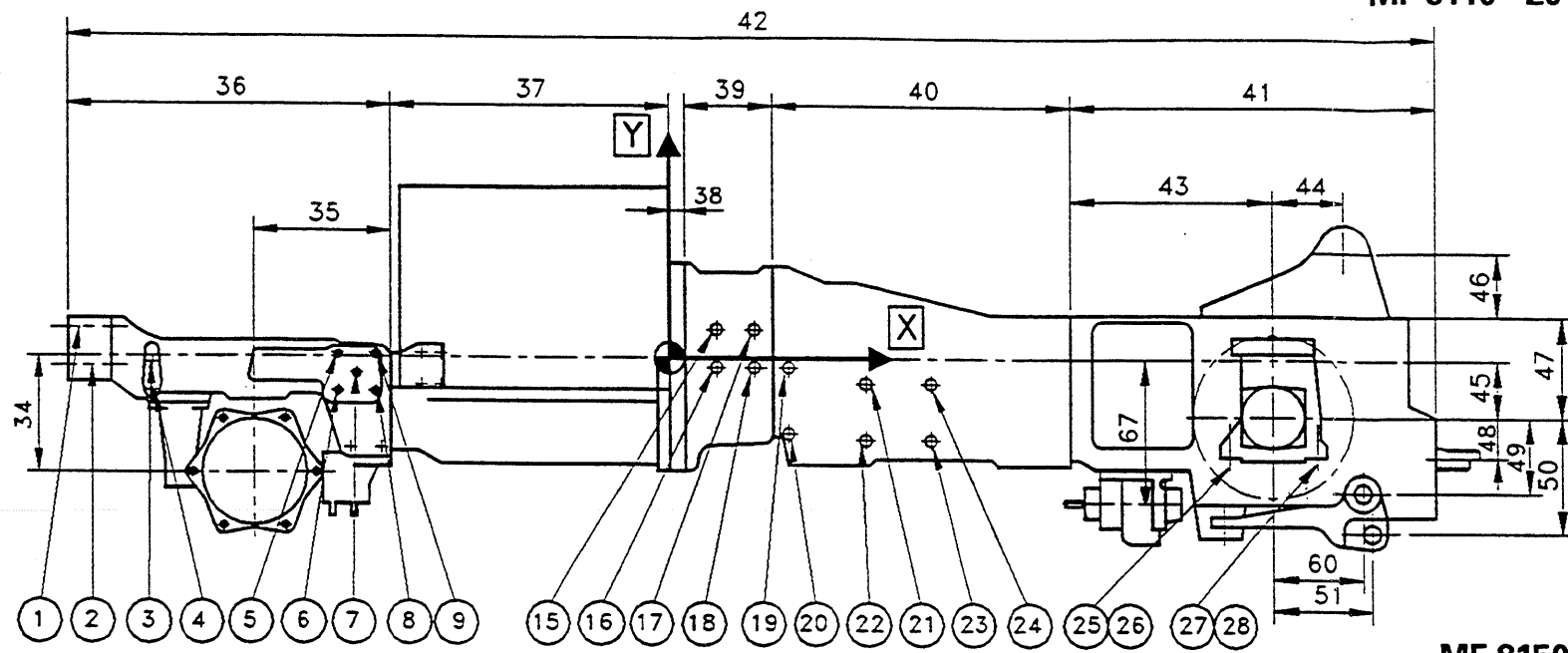

MF 8150 - 60

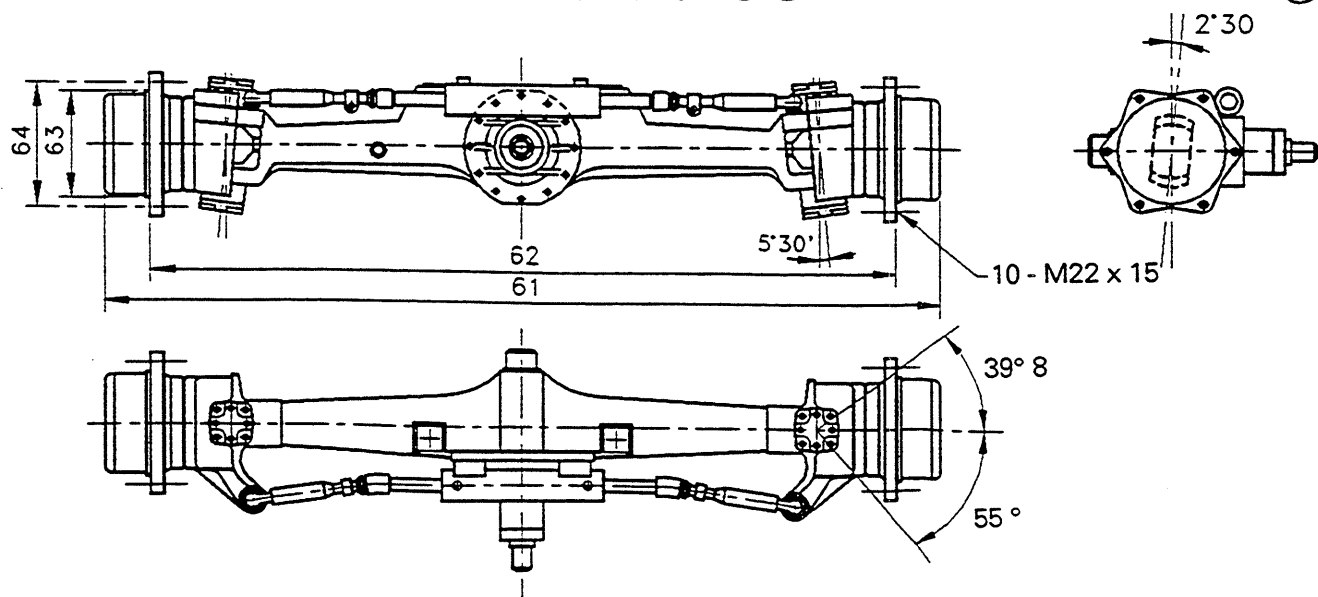
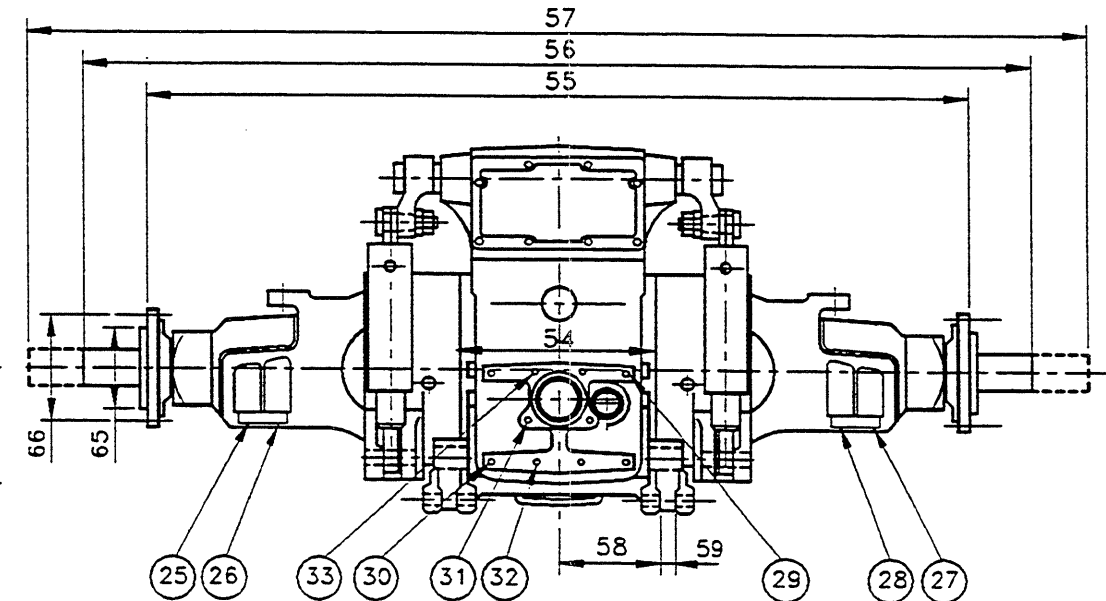
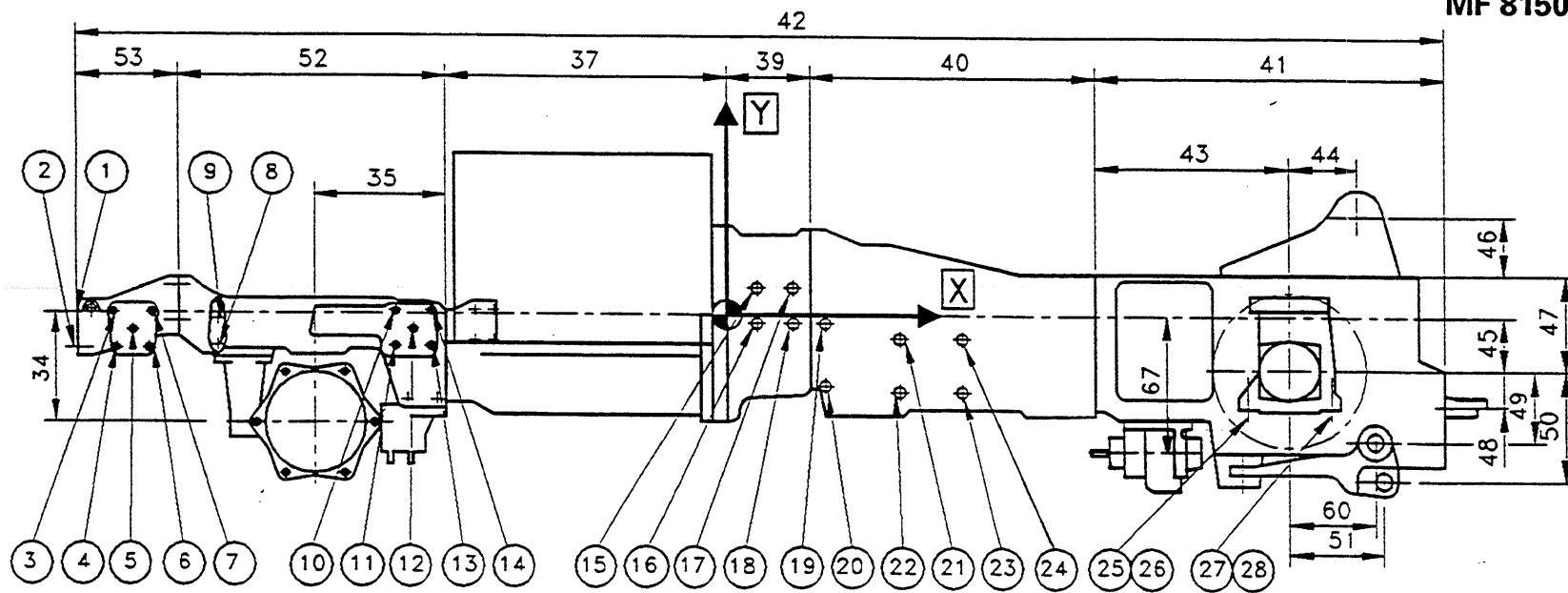



1A01.16

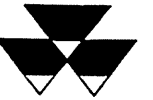

Introduction

D. Safety precautions

When replacing a tractor part bearing a safety decal (yellow) a new safety sticker MUST be affixed onto the replacement part. A full list of the locations for all safety decals are specified below.

G.B. CAUTION



Before operating, read operator's instruction book thoroughly.
Do not start engine until everyone is a safe distance from tractor and equipment.
Keep all shields, covers and guards in place while engine is running.
Keep hands, feet and clothing away from power driven or moving parts.

Always drive with due care and attention.
If differential lock does not disengage automatically, depress clutch pedal.
Brake pedals must always be coupled together when independent brakes are not being used.

When attaching equipment check operator's instruction book for front and rear axle load limits.
Put the gears lever (1-2-3-4) in neutral position and put the reverse/forward lever in forward position or reverse position in order to use the external lift controls.
Ensure that all wheel and rim nuts are tightened as specified in operator's instruction book.
On public roads, use SMV emblem and flashing warning lights where required by law.

Before leaving tractor, apply parking brake, lower equipment, stop engine and remove key from starter switch.

DO NOT REMOVE OR OBSCURE DECAL 3580321 M3

WARNING

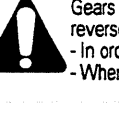

Gears lever (1-2-3-4) must be in his neutral position and the reverse/forward lever in forward position or reverse position:
- In order to use the external lift controls.
- When the driver is not in his seat.

WARNING

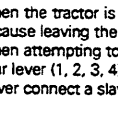

When the tractor is stationary, it is imperative to fully apply the handbrake because leaving the tractor in gear will not prevent movement.
When attempting to start the engine using a slave battery, ensure that the gear lever (1, 2, 3, 4) is in neutral.
Never connect a slave battery directly to the starter motor.

DO NOT REMOVE OR OBSCURE DECAL 3713705 M1



G.B. WARNING



High pressure steam and hot water.
Remove filler cap with extreme care.

DO NOT REMOVE OR OBSCURE DECAL 3595685 M1

G.B.

DO NOT REMOVE OR OBSCURE DECAL

G.B. WARNING



Before working on the tractor, disconnect negative leads to all batteries.

WARNING

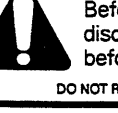

Before removing any battery, disconnect all negative leads before positive leads.

DO NOT REMOVE OR OBSCURE DECAL 3595679 M1

G.B. CAUTION

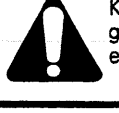

Keep all shields, covers and guards fastened in place while engine is running.

WARNING

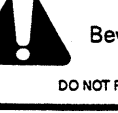

Beware hot parts

DO NOT REMOVE OR OBSCURE DECAL 3595678 M1

G.B. CAUTION

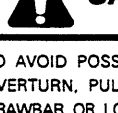

TO AVOID POSSIBLE TRACTOR OVERTURN, PULL ONLY FROM DRAWBAR OR LOWER LINKS OF THREE POINT HITCH

2752579 M1

G.B. WARNING



Always disengage PTO and stop engine before attaching or detaching PTO shafts or working on PTO driven equipment.

Always fit PTO cover when PTO is not in use.

CAUTION



Do not stand between tractor and equipment when operating controls.

Tow only with MF approved tractor drawbar or hitch

DO NOT REMOVE OR OBSCURE DECAL 3581563 M1

G.B. CAUTION



Belt for use only on tractors with safety structures.

DO NOT REMOVE OR OBSCURE DECAL 52784 M3

G.B. WARNING

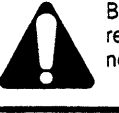

Before working on the tractor or removing this cover, disconnect negative leads to all batteries.

CAUTION



Use seat belt at all times. Keep belt adjusted snugly.

DO NOT REMOVE OR OBSCURE DECAL 3580316 M1

G.B.

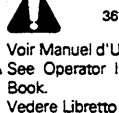

Voir Manuel d'Utilisation. See Operator Instruction Book. Vedere Libretto d'Uso. Siehe Betriebsanleitung Ver Manual del Operador

3617574 M1

CAUTION

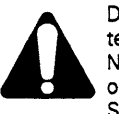

Do not short across starter terminals to start engine. Never start engine while standing on the ground. Start engine only with start key from operator's seat, ensuring that gearbox and PTO are in neutral with parking brake applied.

DO NOT REMOVE OR OBSCURE DECAL 3596432 M1

G.B. WARNING

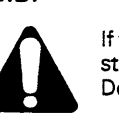

If tractor is overturning, hold onto steering wheel. Do not leave seat



DO NOT REMOVE OR OBSCURE DECAL 3580315 M1

IT IS IMPERATIVE TO USE THE TRANSMISSION OIL RECOMMENDED IN THE OPERATING MANUAL



3713699M1



Introduction

1A01.17

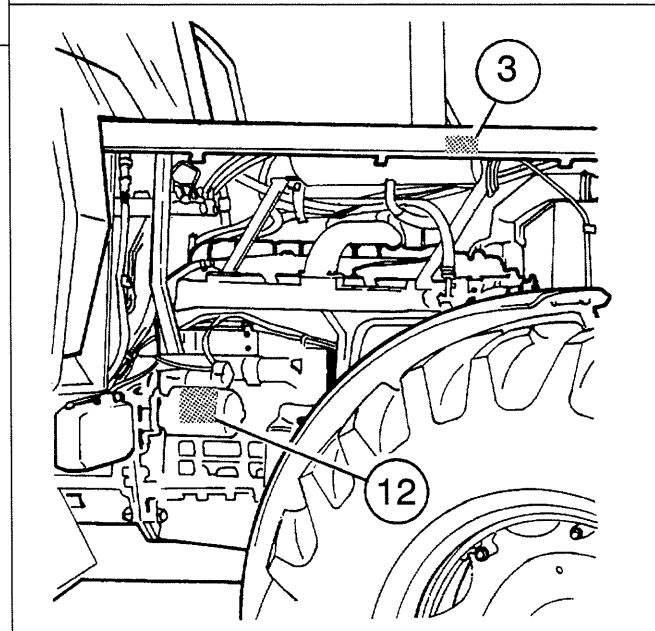
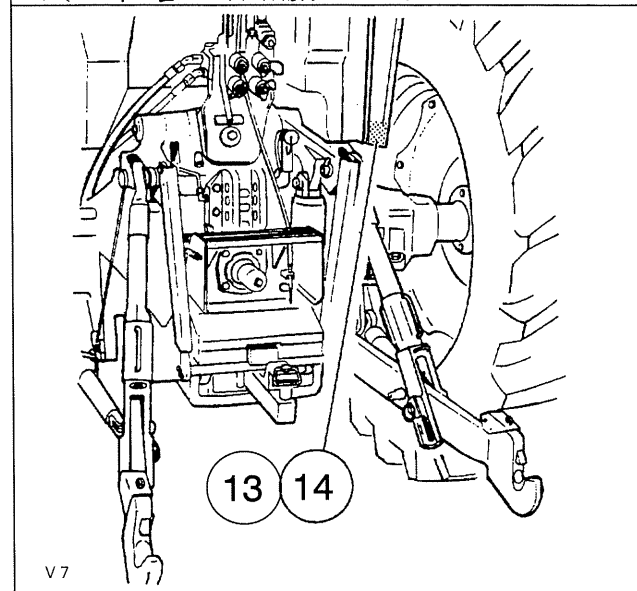
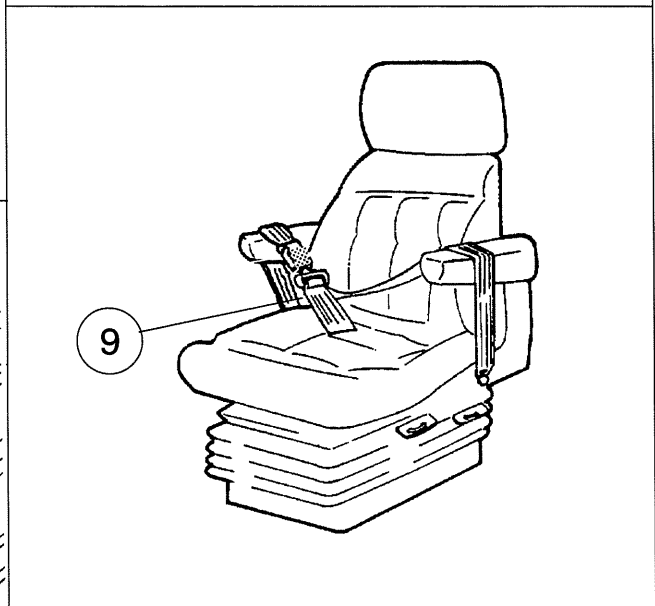
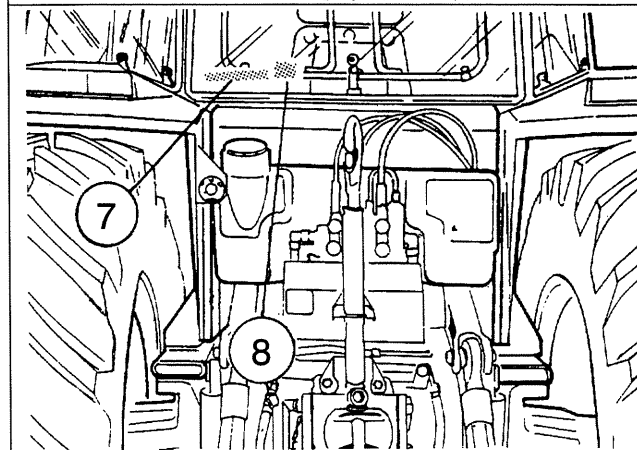
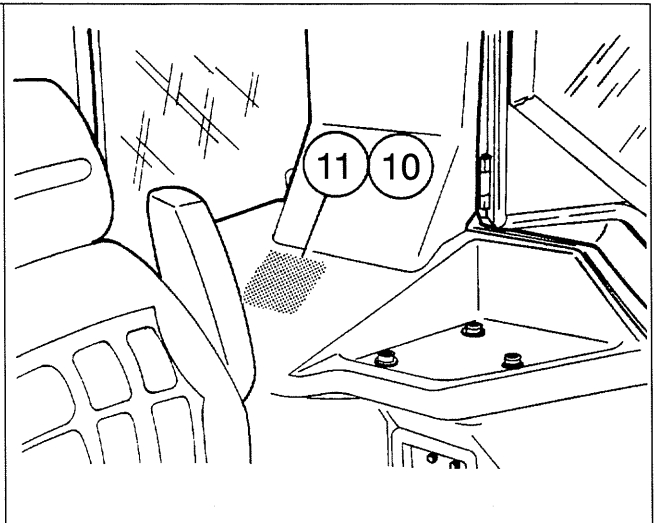
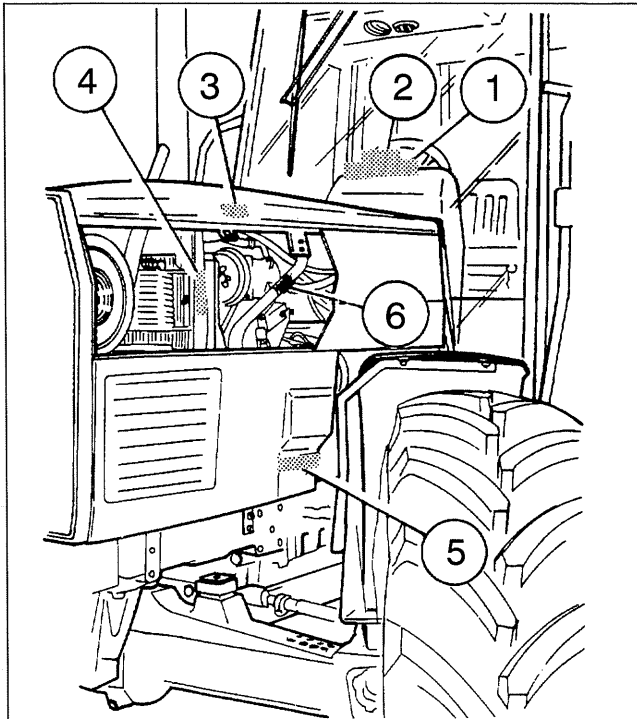

V7

Thanks for your reading.

Please click here to download complete manual instantly.

And can also choose other manuals.

Feel free --->write to me with any questions.

Our service email:

manuals007@hotmail.com