

# EX550-5, EX600H-5 Workshop Manual

---

---

# SECTION 1 GENERAL INFORMATION



## —CONTENTS—

### **Group 1 Precautions for Disassembling and Assembling**

Precautions for Disassembling and Assembling.....	W1-1-1
Maintenance Standard Terminology.....	W1-1-4

### **Group 2 Tightening**

Tightening Torque Specification.....	W1-2-1
Torque Chart .....	W1-2-3
Piping Joint .....	W1-2-6

---

---

(Blank)

# GENERAL INFORMATION / Precautions for Disassembling and Assembling

---

## PRECAUTIONS FOR DISASSEMBLING AND ASSEMBLING

### Precautions for Disassembling and Assembling

- Clean the Machine

Thoroughly wash the machine before bringing it into the shop. Bringing a dirty machine into the shop may cause machine components to be contaminated during disassembling/assembly, resulting in damage to machine components, as well as decreased efficiency in service work.

- Inspect the Machine

Be sure to thoroughly understand all disassembling/assembly procedures beforehand, to help avoid incorrect disassembling of components as well as purchasing unnecessary parts. Check and record the items listed below to prevent problems from occurring in the future.

- The machine model, machine serial number, and hour meter reading.
- Reason for disassembly (symptoms, failed parts, and causes).
- Contamination or clogging of filters and oil, water or air leaks, if any.
- Capacities and condition of lubricants.
- Loose or damaged parts.

- Prepare and Clean Tools and Disassembly Area

Prepare the necessary tools to be used and the area for disassembling work or storing disassembled parts.

- Precautions for Disassembling

- To prevent dirt contamination, cap or plug all removed pipes.
- Before disassembling, clean the exterior of the components and place on a work bench.
- Before disassembling, drain gear oil from the reduction gear.
- Be sure to provide appropriate containers for draining fluids.
- Use matching marks for easier reassembling.
- Be sure to use the specified special tools, when instructed.
- If a part or component cannot be removed after removing its securing nuts and bolts, do not attempt to remove it forcibly. Find the cause(s), then take the appropriate measures to remove it.
- Orderly arrange disassembled parts. Mark and tag them as necessary.
- Store common parts, such as bolts and nuts with reference to where they are to be used and in a manner that will prevent loss.
- Inspect the contact or sliding surfaces of disassembled parts for abnormal wear, sticking, or other damage.
- Measure and record the degree of wear and clearances.

- Precautions for Assembling

- Be sure to clean all parts and inspect them for any damage. If any damage is found, repair or replace it.
- Dirt or debris on the contact or sliding surfaces may shorten the service life of the machine.
- Take care not to contaminate any contact or sliding surfaces.
- Be sure to replace O-rings, backup rings, and oil seals with new ones once they are disassembled. Apply a film of grease before installing.
- Be sure that liquid-gasket-applied surfaces are clean and dry.
- If an anti-corrosive agent has been used on a new part, be sure to thoroughly clean the part to remove the agent.
- Utilize matching marks when assembling.
- Be sure to use the designated tools to assemble bearings, bushings and oil seals.
- Keep a record of the number of tools used for disassembly/assembly. After assembling is complete, count the number of tools, so as to make sure that no tools are missing.

## GENERAL INFORMATION / Precautions for Disassembling and Assembling

---

### Bleeding Air from Hydraulic System

When hydraulic oil is drained, the suction filter or the suction lines are replaced, or the removal and installation of the pump, swing motor, travel motor or cylinder is done, bleed air from the hydraulic system in the following procedures:

- Bleeding Air from Hydraulic Pump

**IMPORTANT: If the engine is started with air trapped in the hydraulic pump housing, damage to the pump may result. Be sure to bleed air before starting the engine.**

- Remove the air bleeding plug from the top of the pump and fill the pump housing with hydraulic oil.
- After the pump housing is filled with hydraulic oil, temporarily tighten the plug. Then, start the engine and run at slow idle speed.
- Slightly loosen the plug to bleed air from the pump housing until hydraulic oil oozes out.
- After bleeding all the air, securely tighten the plug.

- Bleeding Air from Travel Motor / Swing Motor

- With the drain plug (upper side) / hose on travel motor / swing motor removed, fill the motor case with hydraulic oil.

- Bleeding Air from Hydraulic Circuit

- After refilling hydraulic oil, start the engine. While operating each cylinder, swing motor and travel motor evenly, operate the machine under light loads for 10 to 15 minutes. Slowly start each operation (never fully stroke the cylinders during initial operation stage). As the pilot oil circuit has an air bleed device, air trapped in the pilot oil circuit will be bled while performing the above operation for approx. 5 minutes.
- Reposition the front attachment to check hydraulic oil level.
- Stop the engine. Recheck hydraulic oil level. Replenish oil as necessary.

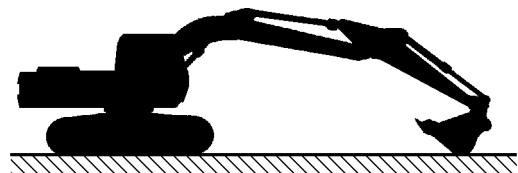

M104-07-021

# GENERAL INFORMATION / Precautions for Disassembling and Assembling

## Precautions for Handling Floating Seal

1. In general, replace the floating seal with a new one after disassembling.

If the floating is to be reused, follow these procedures:

- (1) Keep seal rings together as a matched set with seal ring faces together. Insert a piece of card-board to protect surfaces.
- (2) Check slide surface (C) on seal ring (A) for scuffing, scoring, corrosion, deformation or uneven wear.
- (3) Check O-ring (B) for tears, breaks, deformation or hardening.

2. If incorrectly assembled, oil leaks or damage will occur. Be sure to do the following, to prevent trouble.

- (1) Clean the floating seal and seal mounting bores with cleaning solvent. Use a wire brush to remove mud, rust or dirt. After cleaning, thoroughly dry parts with compressed air.
- (2) Clean the floating seal and seal mounting bores. Check the bore surface for scuffing or scoring by touching the surface with finger.
- (3) Check that the O-ring is not twisted, and that it is installed correctly on the seal ring.
- (4) After installing the floating seal, check that seal surface (C) is parallel with idler face (D) by measuring the distances (a) and (b) as illustrated. If these distances differ, correct the O-ring seating.

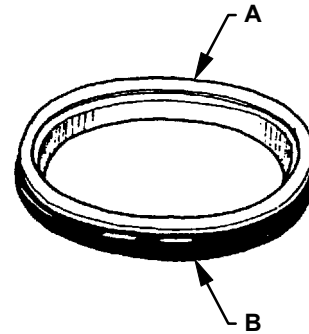

W105-03-05-019

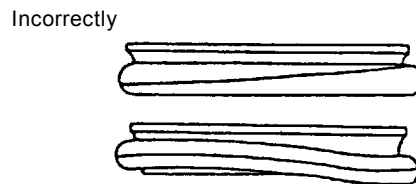
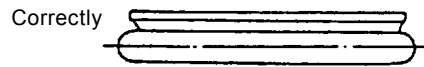
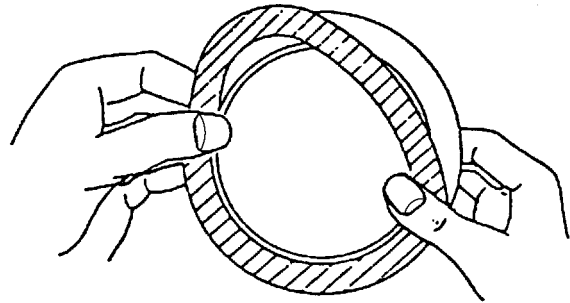

W105-03-05-020

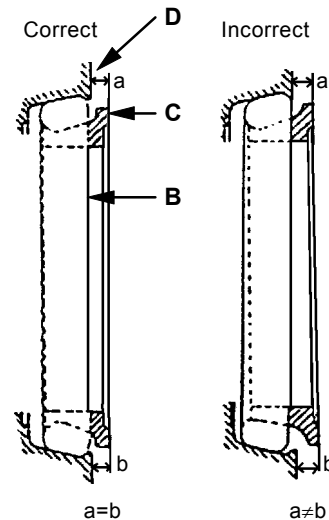

W110-03-05-004

## **GENERAL INFORMATION / Precautions for Disassembling and Assembling**

---

### **MAINTENANCE STANDARD TERMINOLOGY**

#### **“Standard”**

1. Dimension for parts on a new machine.
2. Dimension of components or assemblies adjusted to specification.

Both dimensions are shown with tolerances as necessary.

#### **“Allowable Limit”**

1. Normal machine performance cannot be accomplished after exceeding this limit.
2. Repair or replacement is required before reaching this limit.

Machine performance will decrease, and maintenance and down time expense will increase as machine operating hours accumulate. It is recommended that parts are repaired or replaced before reaching the **“Allowable Limit”**.

## GENERAL INFORMATION / Tightening

### TIGHTENING TORQUE SPECIFICATIONS

Bolt and Nut on Base Machine Standard Torques

Torque Specifications

No.	Descriptions		Bolt Dia mm	Q'ty	Wrench Size mm	Torque			
						N·m	kgf·m	lbf·ft	
1	Engine cushion rubber mounting bolt	Front	Engine cushion rubber	16	2	24	205	21	152
			Cushion rubber-machine	16	2	24	205	21	152
	Rear	Engine cushion rubber	22	2	32	540	55	400	
		Cushion rubber-machine	16	4	24	205	21	152	
2	Radiator mounting bolt		16	4	24	205	21	152	
3	Hydraulic oil tank mounting bolt		16	8	24	205	21	152	
4	Fuel tank mounting bolt		16	8	24	205	21	152	
5	ORS fittings for hydraulic hoses and piping		1-3/16-12UNF		36	175	18	130	
			1-7/16-12UNF		41	205	21	152	
6	Pump transmission mounting bolt		7/16-14UNF	14	16	69	7	51	
7	Pump device mounting bolt		20	8	30	390	40	290	
8	Control valve mounting bolt		20	4	30	390	40	290	
9	Swing device mounting bolt		22	26	32	740	75	540	
	Ring gear housing mounting bolt (hexagonal wrench)		18	24	14	295	30	215	
10	Swing motor mounting bolt (hexagonal wrench)		12	16	10	88	9	65	
11	Battery mounting nut		12	2	19	34	3.5	25.5	
12	Cab mounting bolt		STD, LC	16	4	24	205	21	152
			H, LCH	16	6	24	205	21	152
13	Swing bearing mounting bolt to upperstructure		30	36	46	1910	195	1410	
	Swing bearing mounting bolt to undercarriage		30	36	46	1720	175	1270	

Continued on next page



## GENERAL INFORMATION / Tightening

Torque Specifications (continued)

No.	Descriptions	Bolt Dia mm	Q'ty	Wrench Size mm	Torque			
					N-m	kgf-m	lbf-ft	
14	Travel device mounting bolt	22	40	32	740	75	540	
	Travel motor mounting bolt	18	8	27	295	30	215	
	Sprocket mounting bolt	22	48	32	32	75	540	
15	Upper roller mounting	20	24	30	540	55	400	
16	Lower roller mounting bolt	STD, H	24	64	36	930	95	690
		LC, LCH	24	72	36	930	95	690
17	Track shoe bolt	STD, H	24	392	32	1370	140	1010
		LC, LCH	24	416	32	1370	140	1010
18	Track guard mounting bolt	STD, H	24	16	36	930	95	690
		LC, LCH	24	24	36	930	95	690
19	Track frame mounting bolt	33	36	50	2160	225	1590	
20	Coupling and clamp of low pressure piping	Coupling	8		13	10.5 to 12.5	10.5 to 1.26	7.6 to 9.1
		Clamp	1/4-28UNF		11	5.9	0.6	4.3
21	Counterweight mounting bolt	45	2	65	2750	280	2030	
	Counterweight retaining bolt	24	4	36	440	45	330	
22	Front pin-retaining bolt	20		30	390	40	290	
	Front pin-retaining nut	20		30	390	40	290	

-  **NOTE:** 1. When tightening bolts and nuts, apply a lubricant to threads to reduce friction. (i.e.: white zinc B dissolved into spindle oil)
2. Remove rust, soil, and dust before tightening.
3. Use LOCTITE to the engine cushion rubber mounting nuts and the lower roller mounting bolts.

## GENERAL INFORMATION / Tightening

### TORQUE CHART



**CAUTION:** Use tools appropriate for the work to be done. Makeshift tools and parts create safety hazards. If an incorrect tool is used, the tool may slip or come off or break, resulting in personal injury.



#### Bolt Types

When tightening bolts and nuts, use the specified torque. Bolts are classified according to materials and applications. Be sure to use the correct bolts and nuts, and tighten them to specification.

SA-040

Hexagon T Bolt

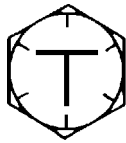

Hexagon H Bolt

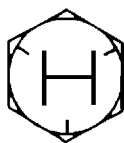

Hexagon M Bolt



Socket Bolt

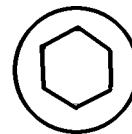

W105-01-01-007

### Specified Tightening Torque Chart

Bolt Dia.	Wrench Size	Hexagon Wrench Size	T Bolt, Socket bolt			H Bolt			M Bolt		
			N·m	kgf·m	lbf·ft	N·m	kgf·m	lbf·ft	N·m	kgf·m	lbf·ft
M 8	13	6	29.5	3	22	19.5	2	14.5	9.8	1	7.2
M 10	17	8	64	6.5	47	49	5	36	19.5	2	14.5
M 12	19	10	108	11	80	88	9	65	34	3.5	25.5
M 14	22	12	175	18	130	137	14	101	54	5.5	40
M 16	24	14	265	27	195	205	21	152	78	8	58
M 18	27	14	390	40	290	295	30	220	118	12	87
M 20	30	17	540	55	400	390	40	290	167	17	123
M 22	32	17	740	75	540	540	55	400	215	22	159
M 24	36	19	930	95	690	690	70	505	275	28	205
M 27	41	19	1370	140	1010	1030	105	760	390	40	290
M 30	46	22	1910	195	1410	1420	145	1050	540	55	400
M 33	50	24	2550	260	1880	1910	195	1410	740	75	540
M 36	55	27	3140	320	2310	2400	245	1770	930	95	690

## GENERAL INFORMATION / Tightening

- IMPORTANT:**
- (1) Apply lubricant (i.e. white zinc B dissolved into spindle oil) to nuts and bolts to reduce friction.
  - (2) Torque tolerance should be  $\pm 10\%$ .
  - (3) Be sure to use bolts of correct length. Bolts that are too long cannot be tightened, as the bolt tip comes into contact with the bottom of the bolt hole. Bolts that are too short cannot develop sufficient tightening force.
  - (4) The torques given in the chart are for general use only.  
Torque as specified.
  - (5) Make sure that the nut and bolt threads are clean before installing.  
Remove dirt or corrosion, if any.

### Bolt Tightening Order

When tightening two or more bolts, tighten them alternately, as shown, to ensure even tightening.

Equally tighten upper and lower alternately

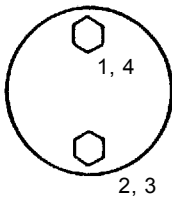

Tighten diagonally

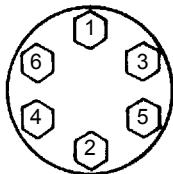

Tighten from center and diagonally

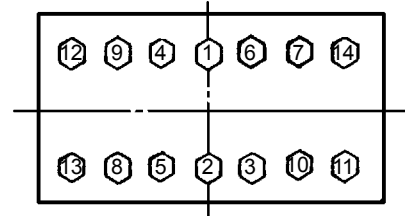

W105-01-01-003

# GENERAL INFORMATION / Tightening

## Service Recommendations for Split Flange

- IMPORTANT:** (1) Be sure to clean and inspect sealing surfaces. Scratches / roughness cause leaks and seal wear. Unevenness causes seal extrusion. If defects cannot be polished out, replace the component.
- (2) Be sure to use only specified O-rings. Inspect O-rings for any damage. Take care not to file O-ring contact surfaces. When installing an O-ring into a groove, use grease to hold it in place.
- (3) Loosely assemble split flange halves. Make sure that the split is centrally located and perpendicular to the port. Hand-tighten the bolts to hold the parts in place. Take care not to pinch the O-ring.
- (4) Tighten bolts alternately and diagonally, as shown, to ensure even tightening.
- (5) Do not use air wrenches. Using an air wrench often causes tightening of one bolt fully before tightening the others, resulting in damage to O-rings or uneven tightening of bolts.

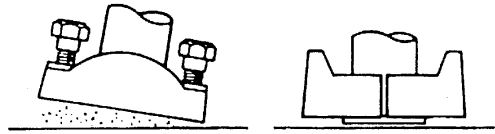

**WRONG**

W105-01-01-015

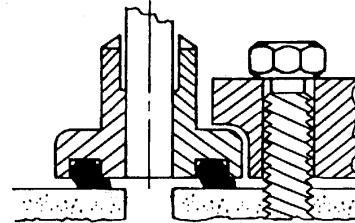

W105-01-01-016

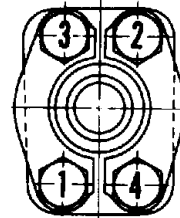

W105-01-01-008

**RIGHT**

**WRONG**

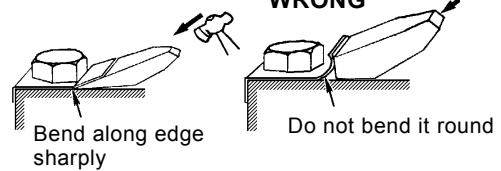

**RIGHT**

**RIGHT**

**WRONG**

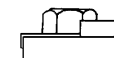
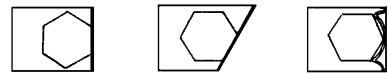

Bend along edge sharply

W105-01-01-009

**RIGHT**

**RIGHT**

**WRONG**

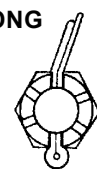
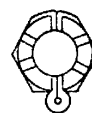

**RIGHT**

**WRONG**

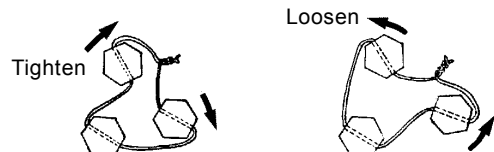

W105-01-01-010

## Nut and Bolt Lockings

### • Lock Plate

**IMPORTANT:** Do not reuse lock plates. Do not try to bend the same point twice.

### • Cotter Pin

**IMPORTANT:** Do not reuse cotter pins. Match the holes in the bolt and nut while tightening, not while loosening.

### • Lock Wire

**IMPORTANT:** Apply wire to bolts in the bolt-tightening direction, not in the bolt-loosening direction.

## GENERAL INFORMATION / Tightening

### PIPING JOINT

#### Pipe Thread Connection / Union Joint Tightening Torque Specifications

##### Union Joint

Metal sealing faces (4) of adapter (1) and (5) of hose (2) fit together to seal pressure oil. Union joints are used to join small-diameter lines.

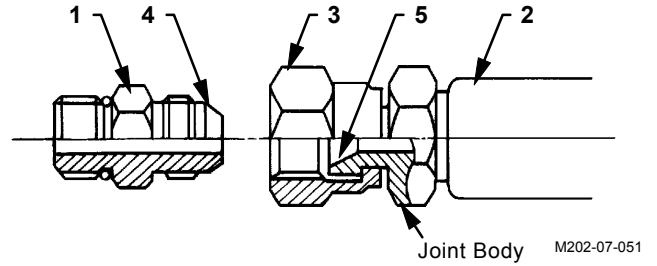

**IMPORTANT:** (1) Do not over-tighten nut (3). If excessive force is applied to metal sealing faces (4) and (5), adaptor (1) will be cracked. Always tighten nut (3) to specifications.

(2) Scratches or other damage to sealing faces (4) or (5) will cause oil to leak at the joint. Take care not to damage the sealing faces when connecting or disconnecting the union joint.

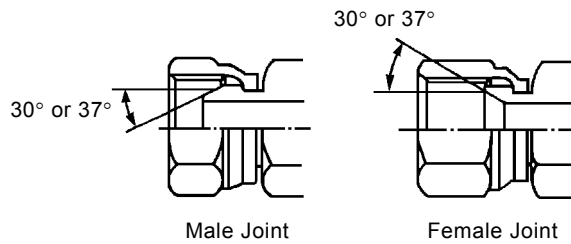

W105-01-01-017

Union Joint	Wrench Size (mm)		Tightening Torque	
	Union Nut	Joint Body	N-m (kgf-m)	lbf-ft
30° Male	19	19	59 (6)	43
	22	22	98 (10)	72
	27	27	118 (12)	87
	36	36	235 (24)	134
	41	41	295 (30)	215
	50	50	490 (50)	360
	60	60	670 (68)	490
	70	70	980 (100)	720
37° Female	19	17	44 (4.5)	32.5
	22	19	59 (6)	43
	27	22	118 (12)	87
	36	30, 32	235 (24)	134
	41	36	295 (30)	125
	50	46	490 (50)	360

**NOTE:** 37° male union joint tightening torque values are equal to those for 37° female union joint.

## GENERAL INFORMATION / Tightening

### O-ring Seal Joint

O-ring (6) is located on the end face of adapter (7) to seal pressure oil at the joint.

- IMPORTANT:**
- (1) Be sure to replace O-ring (6) with new one when reconnecting.
  - (2) Check that O-ring (6) is Correctly seated in O-ring groove (8) before tightening union nut (9). If union nut (6) is tightened with O-ring (6) displaced from the groove, O-ring (6) will be damaged, causing oil leaks.
  - (3) Take care not to damage O-ring groove (8) on adapter (7) and sealing face (10) of the hose end. Damaged O-ring (6) will cause oil leaks.
  - (4) If oil leaks due to looseness of union nut (9), always replace O-ring (6) with new one and check that the O-ring is correctly seated in O-ring groove (8) before re-tightening union nut (9).

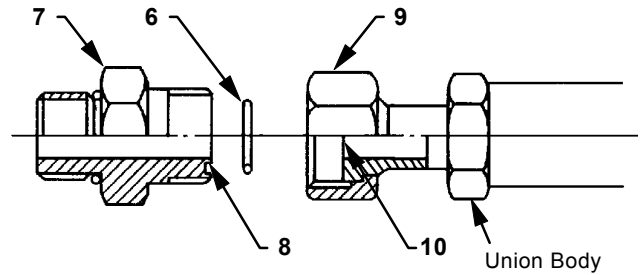

M104-07-033

Wrench Size		Tightening Torque	
Union Nut	Union Body	N·m (kgf·m)	lbf·ft
19	17	59 (6)	43
22	19	98 (10)	72
27	22	118 (12)	87
36	30, 32	235 (24)	134
41	36	295 (30)	215
50	46	490 (50)	360

## GENERAL INFORMATION / Tightening

### Screwed-In Connector

**IMPORTANT:** Many types of screwed-in connectors are used for hose or pipe connections.

Be sure to confirm that the thread pitch and thread type (tapered or straight) correctly match before connection.

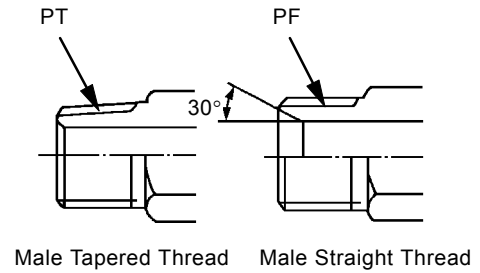

W105-01-01-018

Male Tapered Thread		
Wrench	Tightening Torque	
Joint Body	N·m (kgf·m)	lbf·ft
17, 19	59 (6)	43
19, 22	98 (10)	72
27, 22	118 (12)	87
36, 32	235 (24)	134
41	295 (30)	215
50	490 (50)	360
61	670 (68)	190
70	980 (100)	720

### Seal Tape Application

Seal tape is used to seal clearances between male and female threads, so as to prevent any leaks between threads.

Be sure to apply just enough seal tape to fill up the thread clearances. Wrapping too much tape has no effect.

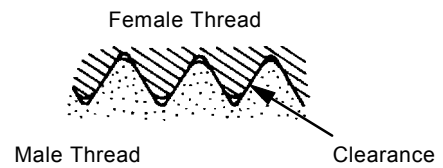

W105-01-01-019

### • Application Procedure

Confirm that the thread surface is clean, free of dirt or damage.

Apply seal tape around threads as shown. Wrap seal tape in the same direction as the threads.

Leave one to two pitch threads uncovered

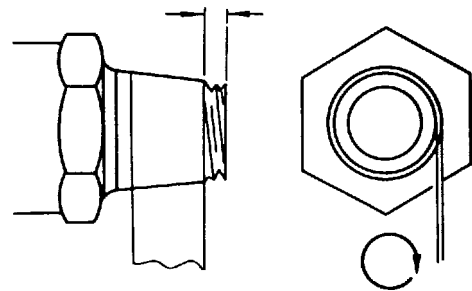

M114-07-041

### Low-Pressure-Hose Clamp Tightening Torque

Low-pressure-hose clamp tightening torque differs depending on the type of clamp.

See below for correct tightening torque of each type of low-pressure-hose clamp.

T-Bolt Type Band Clamp:

4.4 N·m (0.45 kgf·m, 3.25 lbf·ft)

Worm Gear Type Band Clamp:

5.9 to 6.9 N·m (0.6 to 0.7 kgf·m, 4.3 to 5.1 lbf·ft)

T-Bolt Type

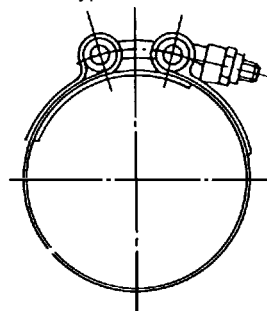

M114-07-042

Worm Gear Type

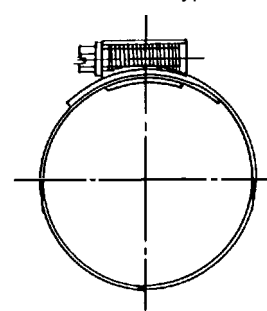

M114-07-043

## GENERAL INFORMATION / Tightening

### Connecting Hose



#### CAUTION:

- (1) When replacing hoses, be sure to use only genuine Hitachi service parts. Using hoses other than genuine Hitachi hoses may cause oil leaks, hose rupture or separation of fitting, possibly resulting in a fire on the machine.
- (2) Do not install hoses kinked. Application of high oil pressure, vibration, or an impact to a kinked hose may result in oil leakage, hose rupture or separation of fitting. Utilize print marks on hoses when installing hoses to check if hoses are installed properly.
- (3) If hoses contact each other, wear on the hoses will result, leading to hose rupture. Take necessary measures to protect hoses from contacting each other. Take care that hoses do not come into contact with moving parts or sharp objects.

WRONG

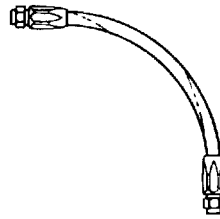

RIGHT

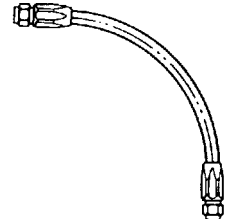

W105-01-01-011

WRONG

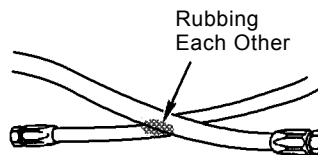

RIGHT

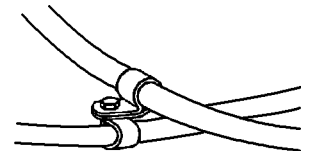

W105-01-01-012

WRONG

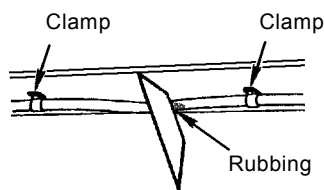

RIGHT

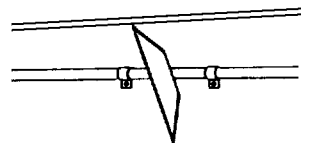

W105-01-01-013

WRONG

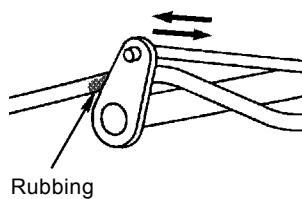

RIGHT

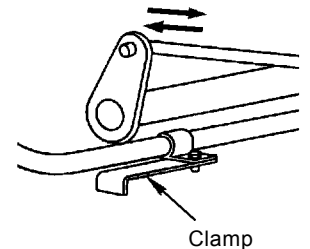

W105-01-01-014



## GENERAL INFORMATION / Tightening

---

(Blank)

---

---

# SECTION 2 UPPERSTRUCTURE

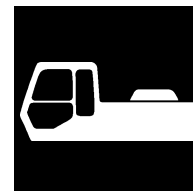

## —CONTENTS—

### Group 1 Cab

Remove and Install Cab .....	W2-1-1
Dimensions of the Cab Glass .....	W2-1-7

### Group 2 Counterweight

Remove and Install Counterweight .....	W2-2-1
---	--------

### Group 3 Pump Device

Remove and Install Pump Device .....	W2-3-1
Disassemble Pump Transmission .....	W2-3-4
Assemble Pump Transmission .....	W2-3-6
Remove and Install Main Pump .....	W2-3-8
Disassemble Main Pump .....	W2-3-10
Assemble Main Pump .....	W2-3-16
Disassemble and Assemble Pilot Pump .....	W2-3-24

### Group 4 Control Valve

Remove and Install Control Valve .....	W2-4-1
Disassemble Control Valve 1 .....	W2-4-4
Assemble Control Valve 1 .....	W2-4-8

Disassemble Control Valve 2 .....	W2-4-14
Assemble Control Valve 2 .....	W2-4-16
Disassemble Control Valve 3 .....	W2-4-18
Assemble Control Valve 3 .....	W2-4-24
Disassemble Control Valve 4 .....	W2-4-30
Assemble Control Valve 4 .....	W2-4-32
Disassemble Control Valve 5 .....	W2-4-34
Assemble Control Valve 5 .....	W2-4-36

### Group 5 Swing Device

Remove and Install Swing Device .....	W2-5-1
Disassemble Swing Device .....	W2-5-4
Assemble Swing Device .....	W2-5-8
Disassemble Swing Motor .....	W2-5-12
Assemble Swing Motor .....	W2-5-16
Maintenance Standard .....	W2-5-20

---

---

## Group 6 Pilot Valve

Remove and Install Right	
Pilot Valve .....	W2-6-1
Remove and Install Left	
Pilot Valve .....	W2-6-4
Remove and Install	
Travel Pilot Valve .....	W2-6-7
Disassemble Front Attachment	
Pilot Valve .....	W2-6-8
Assemble Front Attachment	
Pilot Valve .....	W2-6-10
Disassemble Travel	
Pilot Valve .....	W2-6-14
Assemble Travel	
Pilot Valve .....	W2-6-16

## Group 7 Pilot Shut-Off Valve

Remove and Install	
Pilot Shut-off Valve .....	W2-7-1
Disassemble Pilot Shut-off Valve .....	W2-7-4
Assemble Pilot Shut-off Valve .....	W2-7-6

## Group 8 Shockless Valve

Remove and Install Front	
Attachment Shockless Valve .....	W2-8-1
Disassemble and Assemble Front	
Attachment Shockless Valve .....	W2-8-4
Remove and Install	
Travel Shockless Valve .....	W2-8-7
Disassemble and Assemble	
Travel Shockless Valve .....	W2-8-8

## Group 9 Solenoid Valve

Remove and Install	
Three-Spool Solenoid Valve .....	W2-9-1
Disassemble and Assemble	
Three-Spool Solenoid Valve .....	W2-9-3

## UPPERSTRUCTURE / Cab

### REMOVE AND INSTALL CAB

#### Remove Cab

1. Remove seat mounting nut (2) to remove seat (1).

 : 13 mm

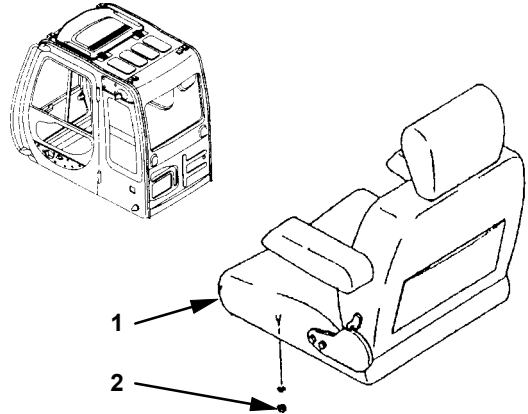

W157-02-01-005

2. Loosen bolt (5) in the cab rear section and bolt (6) in rear boxes (3 and 4) to remove rear boxes (3 and 4).

 : 13 mm

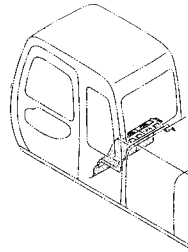

3. Loosen bolt (8) to remove lower cover (7) of the rear box.

 : 13 mm

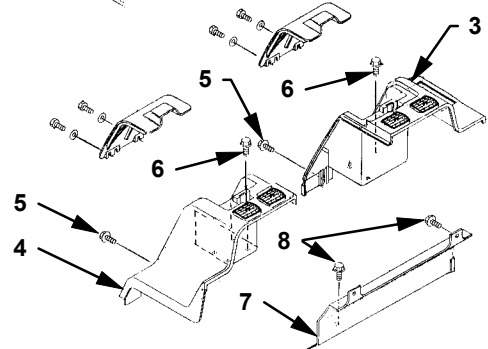

W157-02-01-017

4. Remove filter (24) and loosen screw (9) to remove duct (10) from the cab.

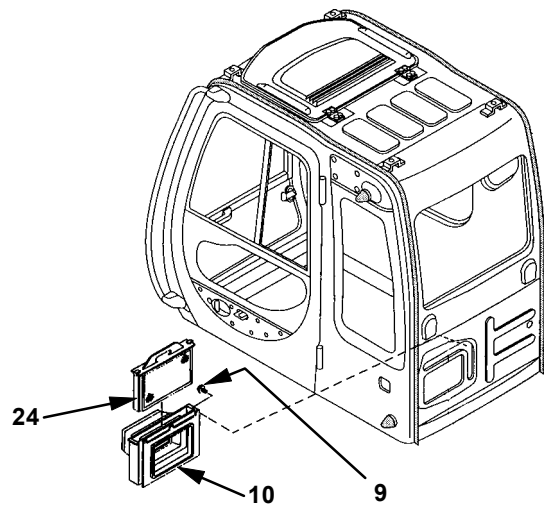

W158-02-01-001

**Thanks for your reading.**

**Please click here to download complete manual instantly.**

**And can also choose other manuals.**

**Feel free --->write to me with any questions.**

**Our service email:**

**manuals007@hotmail.com**