

GEHL

Form No.

913363

Revision F

APRIL

2014

RT210

Compact Track Loader

*Serial Number 20601 through 921000
(Equipped with a TIER III or Interim TIER IV engine)*



Parts Manual

INTRODUCTION

When ordering service parts, specify the correct part number, full description, quantity required, the machine model number, and serial number. For your safety, and continued proper operation, use only genuine Gehl service parts.

“Right” and “Left” are determined from a position sitting on the seat inside the cab and facing forward.

Gehl Company reserves the right to make changes or improvements in the design or construction of any part of the machine without incurring the obligation to install such changes on previously delivered machines.

NOTE: *This parts manual identifies both standard and optional features for this model—including EU (European Union) standards. Depending on the features of your machine, some of the items identified in the parts lists may, or may not, be included with your machine.*

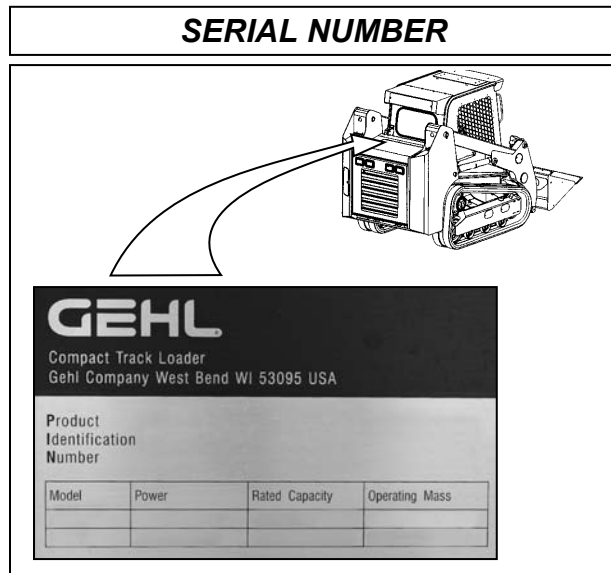

Serial number breaks are indicated as follows:

- (SN 999 and before) - indicates serial numbers up to and including 999.
- (SN 1000 - 2000) - indicates serial numbers from 1000 to 2000.
- (SN 999 and up) - indicates serial numbers including 999 and after.

NOTE: *When ordering parts, be sure to identify the last five digits of the machine's serial number.*

HYDRAULIC AND ELECTRICAL SCHEMATICS

Hydraulic and electrical schematics can be found in the Operator's and Service Manuals for this machine; please refer to the information at the right for the correct manual.

The following icons shown on various pages provide important information or identify where additional information can be found.

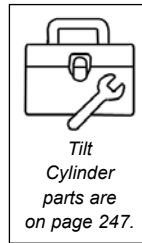

Identifies where additional pages for component parts, seals, and kits can be found.

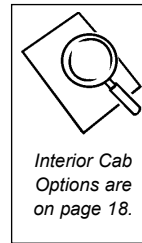

Identifies where additional information can be found.

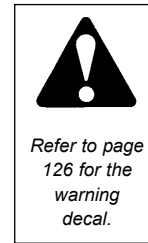

Alerts and directs user to investigate more information.



Identifies missing, hidden parts, or adds informational comments.



Seal Kit



Repair Kit



Represents a port designation on hydraulic components (e.g., valves, cylinders, etc.)

SOME ABBREVIATIONS LISTED IN THIS MANUAL

ASSY	Assembly
AR	As Required
CFPD	Contact Factory Parts Department
EU	European Union (standards)
HYD	Hydraulic
IN	Inch(es)
INC/INCL	Included or includes
LN	Lock Nut
MM/mm	Millimeter
NA	Not Applicable or Not Available
NPT	National Pipe Thread
NSS	Not Sold Separately
ORB	O-Ring Boss
REF	Reference
SN	Serial Number
W/	With
W/O	Without

RELATED MANUALS

Engine Parts Manual: P/N 917304

TABLE OF CONTENTS

Introduction	i
Table of Contents	1
Filters / Belts / Analysis Kits	4
Cab	6
Standard Cab	6
Cab Door - Swing-Out (Option) - (Series III)	8
Cab Door - Swing-Out (Option) - (Series 1 and II)	10
Swing-Out Door Reference - (Series I, II, and III)	12
Swing-Out Door Latches - (Series I, II, and III)	13
Side Windows (Option)	14
Cab Tilt and Rear Window	16
Rear Window - Wiper Assembly	17
Window Washer (Option)	18
Floor Pod / Foot Throttle	19
Interior Covers	20
Sound Suppressing Foam (EU Machines)	21
Headliner - Heat-A/C Ducts	22
Console Controls - Left Side	24
Console Controls - Right Side	25
Console - Right Side (Late Style)	26
Console - Left Side (Late Style)	27
Console - Right Side (Early Style)	28
Console - Left Side (Early Style)	29
Seat	30
Mirror (Option)	32
Radio (Option)	33
Heater Hose Circuit (Option)	34
Heater / Air Conditioning Blower (Option)	36
Rear Cab - HVAC Cover	38
Air Conditioning Circuit (Option)	40
Chassis	42
Frame - Front / Under	42
Counterweights / Center Frame	43
Rear Door	44
Rear Access Doors	46
Rear Hood	48
Rear Hood - Air Conditioning Condenser Assembly (Option)	49
Sound Suppressing Foam — Rear Chassis (EU Machines)	50
Electrical	52
Chassis Wire Harness / Components	52
Fuse Boxes / Fuses / Relays	54
Battery Circuit / Engine Wire Harness	56

TABLE OF CONTENTS

Electrical (continued)	
Operator Wire Harness - Cab	58
Work Lights Cab / ROPS Wire Harness	59
Engine	60
External Components	60
—Right Side	60
—Left Side	62
—Mounts	64
—Flywheel Housing	65
Fuel Circuit	66
Fuel Tank (Series II)	68
Fuel Tank (Series I)	69
Air Intake / Exhaust	70
Air Conditioning Compressor (Option)	72
Engine / Hydraulics	74
Radiator / Hydraulic Coolers	74
Tracks	76
Track Assembly	76
Dual-Flange Idler Assembly	78
Dual-Flange Bogie Wheel Assembly	79
Front Idler Assembly	80
Track Drive Motor and Sprocket	81
Track Drive Motor Components	82
Loader Arm	84
Bolt-On Components	84
Attachment Bracket - Manual (Standard)	86
Bucket	87
Attachment Bracket Power All-Tach [®] (Option)	88
14-Pin Connector (Option)	90
Loader Arm Hydraulics	92
Tilt Circuit	92
Lift Circuit	94
Auxiliary Circuit - (Standard)	96
High-Flow Hydraulics Circuit - (Option)	97
Hydraulics	98
Hydraulic Tank	98
Hydraulic Filter Assembly	100
Hydrostatic Drive Pump Circuit (SN 21072 - 921000)	102
Hydrostatic Drive Pump Circuit (SN 21071 and before)	104
Hydraulic Pump Circuit - (Standard Hydraulics)	106
Hydraulic Pump Circuit (High-Flow Hydraulics)	108

TABLE OF CONTENTS

Hydraulics (continued)

Track Drive Circuit - Right Side (SN 21072 - 921000)	110
Track Drive Circuit - Right Side (SN 20865 - 21071)	112
Track Drive Circuit - Right Side (SN 20864 and before)	114
Track Drive Circuit - Left Side (SN 21072 - 921000)	116
Track Drive Circuit - Left Side (SN 20865 - 21071)	118
Track Drive Circuit - Left Side (SN 20864 and before)	120
Self-Level Valve Circuit - Lift / Tilt	122
Auxiliary / High-Flow Hydraulics Circuit	124
Pilot Pressure Manifold Circuit (SN 20865 - 921000)	126
Pilot Pressure Manifold Circuit (SN 20864 and before)	128
Float Circuit - (Standard) / Hydraglide™ Ride Control - (Option)	130

Hydraulic Components

Hydrostatic Drive Pump	132
Hydraulic Pump - Standard Hydraulics	134
Hydraulic Pump - High-Flow Hydraulics	135
Hydraulic Main Valve - (Standard Hydraulics)	136
Hydraulic Main Valve - (High-Flow Hydraulics)	137
Self-Level Valve - (Standard)	138
Self-Level Valve - (Switchable)	139
Float Manifold - (Standard)	140
Hydraglide™ Ride Control Manifold (Option)	141
Pilot Pressure Manifold	142
Track Tension Cylinder	143
Tilt Cylinder	144
Lift Cylinder	145

Decals

Paint / Decal Application / General Information	146
Front	147
Right Side (Late Style)	148
Left Side (Late Style)	149
Right Side (Early Style)	150
Left Side (Early Style)	151
Rear	152
Engine Compartment	153

Numerical Index

Subject Index

Reference

O-Ring Tables	170
Adapter (Fittings) Torque Guide	171
Metric Bolt Torque Guide	172
SAE and Metric Bolt Torque Guide	173

RT210 - MAINTENANCE
FILTERS / BELTS / ANALYSIS KITS

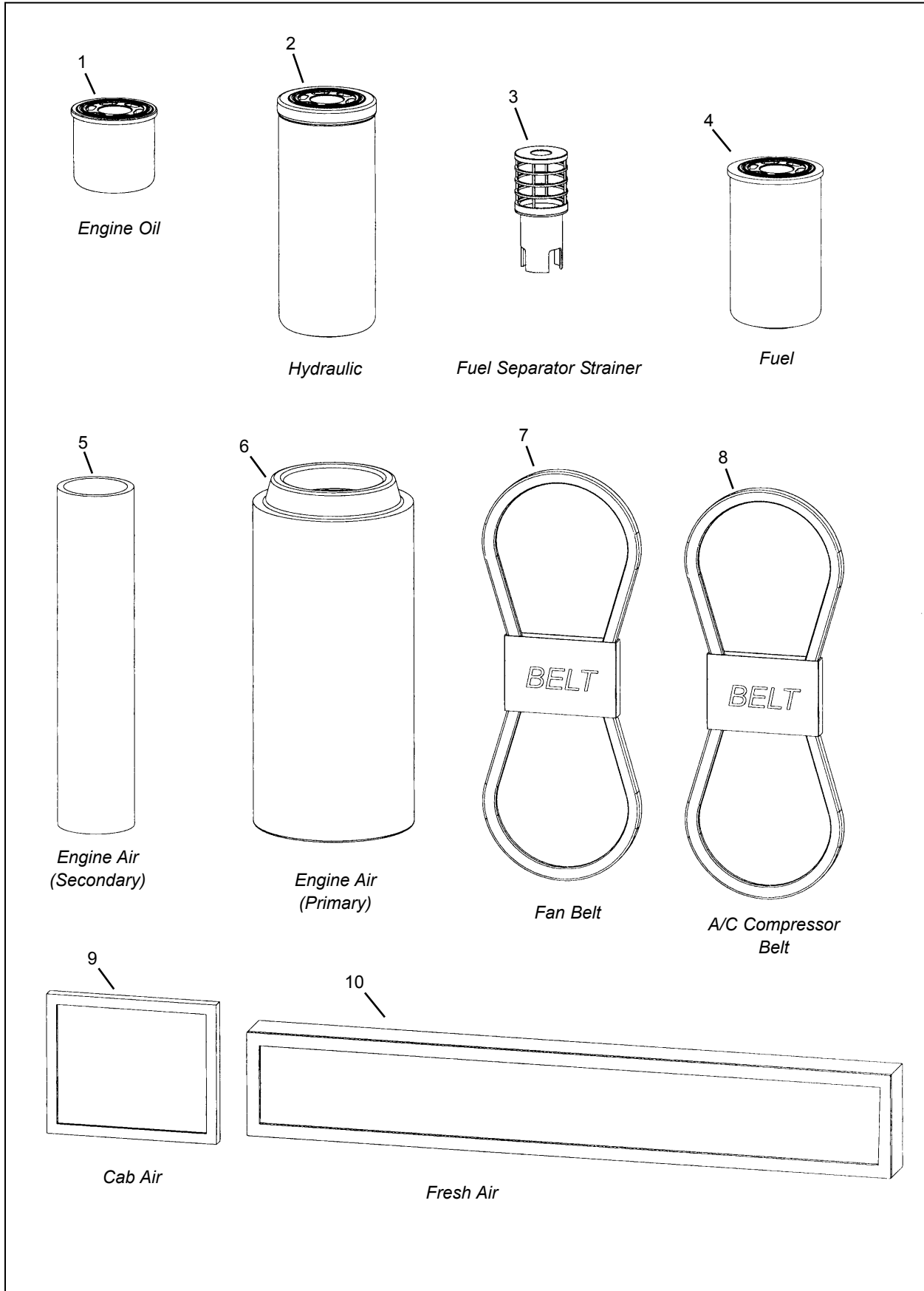

RT210 - MAINTENANCE FILTERS / BELTS / ANALYSIS KITS

Item No.	Part No.	Description	Qty.
01	195568	FILTER, ENGINE OIL	1
02	074830	FILTER, HYDRAULIC	1
03	203822	STRAINER/ELEMENT <i>(used in fuel separator assembly)</i>	1
04	193024	FILTER, FUEL	1
05	184195	FILTER, ENGINE AIR <i>(secondary)</i>	1
06	184146	FILTER, ENGINE AIR <i>(primary)</i>	1
07	241477	FAN BELT	1

Item No.	Part No.	Description	Qty.
08	271491	A/C COMPRESSOR BELT *	1
09	242832	FILTER, RECIRCULATION AIR *	2
10	195660	FILTER, FRESH AIR *	1
11	50300431	CABLE, J1939 JUMPER <i>(included with Kit 241766)</i>	1

* Used when equipped with air conditioning or heater.

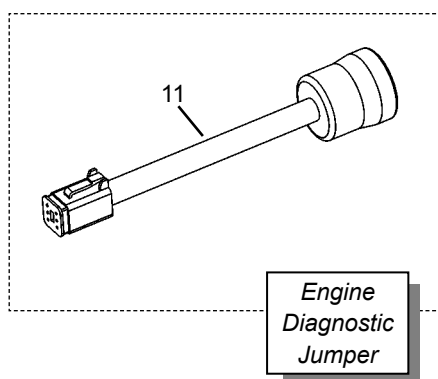

Analysis Kits*

	Qty.
272806.	HYDRAULIC OIL ANALYSIS KITS (10)
272809	ENGINE OIL ANALYSIS KITS (10)
272811	BASIC FUEL ANALYSIS KIT (1)
272812.	COOLANT ANALYSIS KITS (10)
272813.	FIELD TEST COOLANT STRIP KIT (1)
272814	OIL VACUUM PUMP (1)
272815	COOLANT VACUUM PUMP (1)
272816.	1/4" PLASTIC TUBING (100-FOOT ROLL)

* For the analysis of fluids and lubricants used in this machine. Contact your dealer for more information.

RT210 - CAB STANDARD CAB

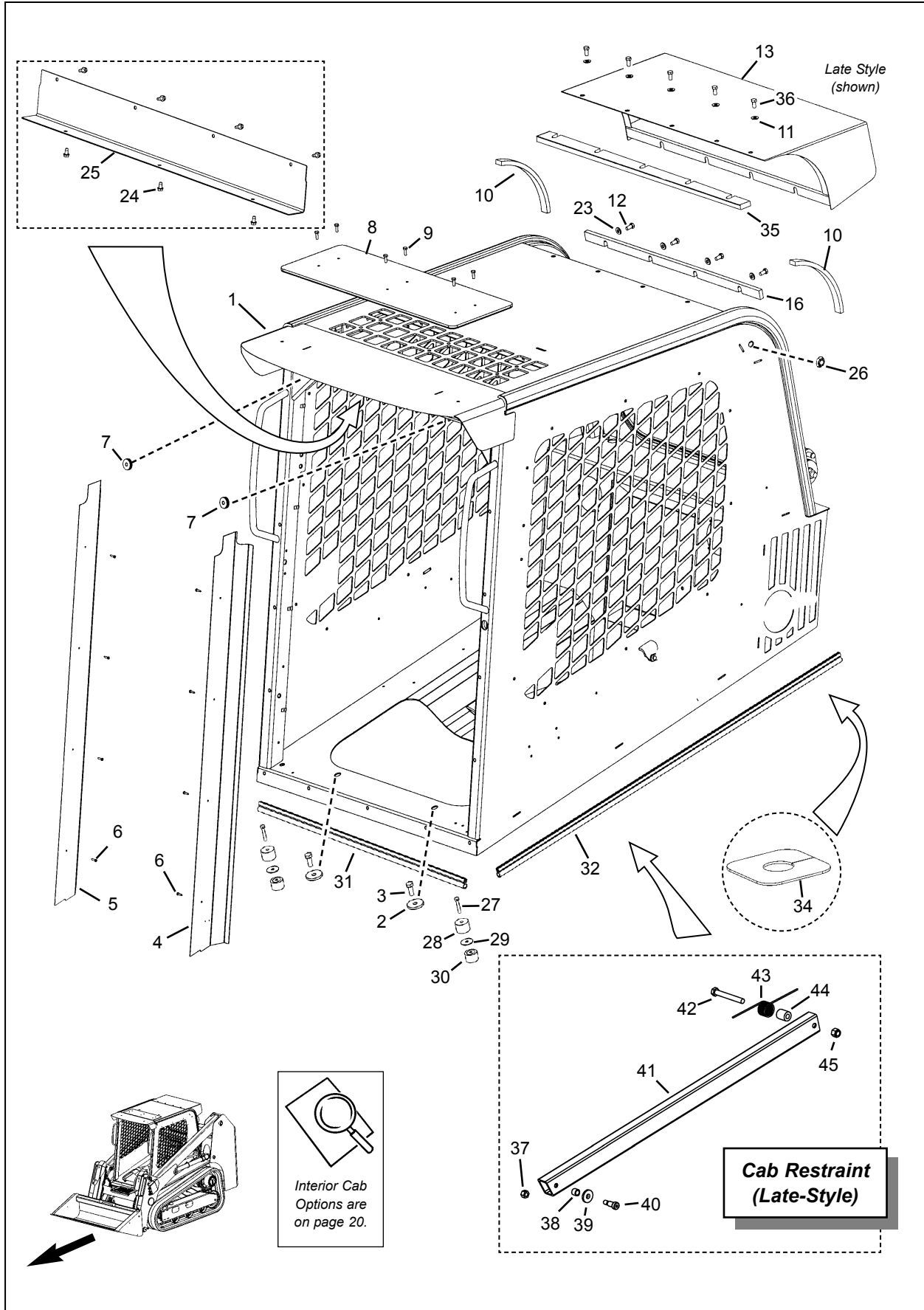

RT210 - CAB STANDARD CAB

Item No.	Part No.	Description	Qty.
01	50302312	ROPS WELDMENT	1
02	057557	FW 17/32 ZY	2
03	650495	CS 1/2" x 1-1/4" C5ZY	2
04		COVER, POST (Left) (see below)	1
	50300218	(Standard - no door)	
	50300210	(Swing-Out Door - w/ heater)-(Option)*	
	50300215	(Swing-Out Door - no heater)-(Option) *	
05		COVER, POST (Right) (see below)	1
	50300219	(Standard - no door)	
	50300212	(Swing-Out Door - w/ heater)-(Option)*	
	50303419	(Swing-Out Door - no heater)-(Option)* (Series II latch - see next page)	
	50300216	(Swing-Out Door - no heater)-(Option)* (Series I latch - see next page)	
06	651783	SCREW, TPH TF CR #8-32x3/4 CZY	8
07	242633	GROMMET, 0.375"x0.188GW 1.0	2
08	270848	WINDOW, TOP	1
09	650835	CS 1/4" x 1" C5ZY	6
	137462	WASHER, 1/4" SEALING	6
10	271627	SEAL, FOAM SIDE	2
11	135270	WASHER, SEALING 3/8"	
		Note a	5
		Note b	4
12	650488	CS 3/8" x 3/4" C5ZY	4
13		WELDMENT, REAR BILL **	1
	50301826	Note a	
	274784	Note b	
14	654004	FW 5/16" AWZY	2
15	650484	CS 5/16" x 1/2" C5ZY	2
16	274788	SEAL, FOAM	1
17		WELDMENT, REAR BILL ***	1
	50301820	Note a	
	274807	Note b	
18	195660	FILTER, FRESH AIR ***	1
19	275598	COVER, FRESH AIR FILTER ***	1

Item No.	Part No.	Description	Qty.
20	275599	PAD, HOUSING LH	1
21	275601	PAD, HOUSING TOP	1
22	275600	PAD, HOUSING RH	1
23	654049	FW 3/8 ANZY	4
24	651783	SCREW/TPHTF CR *8-32x3/4	7
	650606	FW #8 AZ (not shown)	7
25	50300057	COVER, DOOR HEADER	1
26	192182	PLUG, RUBBER	2
27	650568	CS 5/16" x 2" C5ZY	2
28	50301141	SPACER	2
29	50301434	SPACER	2
30	275016	ISOLATOR, 1" x 1-1/2" RUBBER	2
31	50301581	SEAL, BULB 0.63" x 37.5"	1
32	50301580	SEAL, BULB 0.63" x 56.25"	2
33	50300901	GASKET, RUBBER (A/C-Heater)	1
34	50301118	GROMMET, CAB ELECTRICAL	1
35		SEAL, FOAM	1
	50301824	Note a	
	274788	Note b	
36		BOLT	
	650490	Note a — CS 3/8" x 1" C5ZY	5
	650488	Note b — CS 3/8" x 3/4" C5ZY	4

CAB RESTRAINT (Series II)

37 ^c	210-31017	LN FL CTR 5/16 CFZY	1
38 ^c	50302309	BUSHING, BRONZE	1
39 ^c	50302473	WASHER, BEVELED	1
40 ^c	030-31941	SCREW, SHOULDERED 3/8 "x5/8"	1
41 ^c	50302182	CAB RESTRAINT, WELDMENT	1
42 ^c	650818	CS 3/8" x 3" C5ZY	1
43 ^c	50301852	SPRING, TORSION	1
44 ^c	50302181	SPACER	1
45 ^c	067847	HLN INST 3/8" CZY	1

* When machine is equipped with optional swing-out door.

** Machines not equipped with optional heater or A/C.

*** Machines equipped with optional heater or A/C.

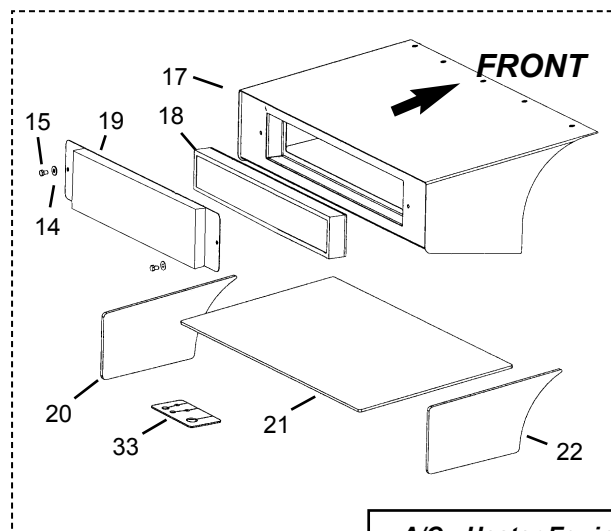

- a SN 20735 - 921000; the top of the rear bill weldment—item 13—uses five bolts to secure the weldment to the cab.
- b SN 20734 and before; the top of the rear bill weldment—item 13—uses four bolts to secure the weldment to the cab.
- c Used with late-style ROPS—SN 21041 - 921000; Early-style ROPS—SN 21040 and before—uses a pin at the rear of the cab to restrain the cab for servicing components under the cab. The pin is shown as item 4 on page 16.

**A/C - Heater Equipped
(Option) — (Rear of Cab)**

RT210 - CAB
CAB DOOR - SWING-OUT - (OPTION)
(Series III) *

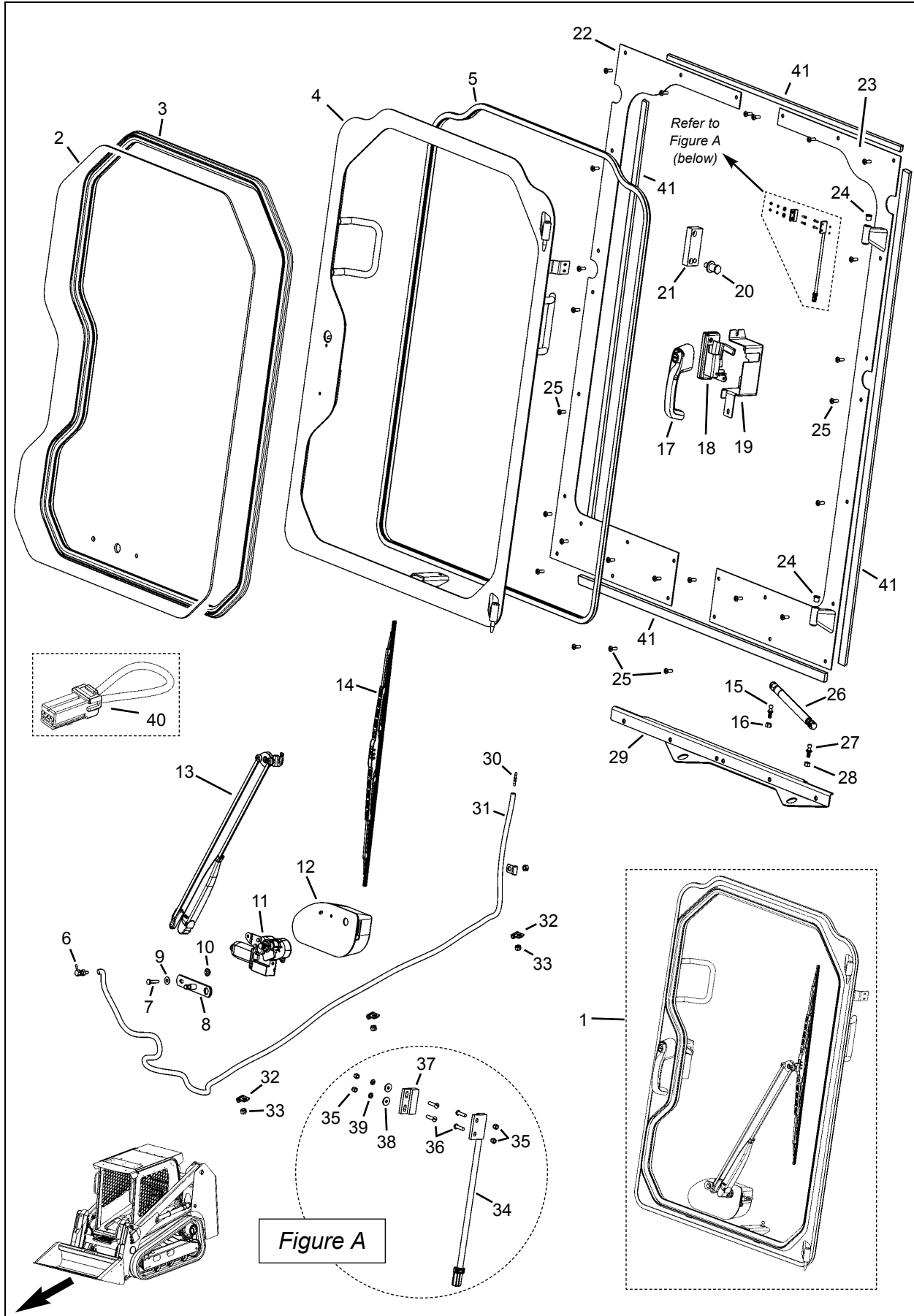

Thanks for your reading.

Please click here to download complete manual instantly.

And can also choose other manuals.

Feel free --->write to me with any questions.

Our service email:

manuals007@hotmail.com