

1840

Forage Box & Chassis Units

Form No.
909861
Revision C



PARTS MANUAL

GEHL® AGRICULTURE

Introduction

When ordering service parts, specify the correct part number, full description, quantity required, the unit model number and serial number.

The model number and serial number for this unit are on a decal located on the left side of the box frame just forward of the chain reduction drives. “Right” and “left” are determined from a position standing at the rear of the unit and looking toward the direction of travel.

GEHL Company reserves the right to make changes or improvements in the design or construction of any part of the unit without incurring the obligation to install such changes on any previously delivered units.

NOTE: *On original tire replacement, Company policy prohibits the sale of replacement tires for all GEHL machinery. Replacement wheel sets are available and tire size information is called out with the wheel sets to facilitate replacement tire selection. ALL REPLACEMENT TIRES MUST BE PURCHASED LOCALLY.*

Refer to the abbreviations table located on this page for the various fastener descriptions. Standard attaching hardware torque values are also provided on the inside back cover.

In the exploded view parts list, Reference Numbers may have additional information following the Reference Number. A number inside a hexagon will be the torque value required, in foot-pounds, on the associated Reference Number. Items shown in the parts list that do not have Reference Numbers are shown for reference purposes only and are NOT available for purchase.

Unless otherwise specified, all cap screws or bolts are Grade 5, zinc plated; hexagon nuts for Grade 5 screws or bolts are Grade B; hexagon nuts for other screws or bolts are Grade A.

NOTE: *The following abbreviations may be used herein:*

| | |
|---|----------------------------------|
| A/R | - As Required |
| ASSD | - Assembled |
| ASSY | - Assembly |
| CB | - Carriage Bolt |
| CCW | - Counterclockwise |
| CP | - Cotter Pin |
| CS | - Cap Screw (Hexagon Head) |
| CTR | - Center |
| CW | - Clockwise |
| DEG | - Degree |
| DIA | - Diameter |
| FCS | - Flanged Cap Screw |
| FHMS | - Flat Head Machine Screw |
| FL | - Flanged |
| FLN | - Flanged Lock Nut (Hexagon) |
| FLS | - Flanged Lock Screw (Hexagon) |
| FW | - Flat Washer |
| GA | - Gauge |
| GR | - Grade |
| HD | - Hard or Head |
| HN | - Hex Nut |
| INCL | - Includes |
| JT | - Joint |
| LG | - Large |
| LN | - Lock Nut |
| LW | - Lock Washer |
| LT | - Left |
| M | - Metric |
| MM/mm | - Millimeter |
| NF | - National Fine |
| PB | - Plow Bolt |
| PTO | - Power Take Off |
| RHMS | - Round Head Machine Screw |
| RPM | - Revolutions Per Minute |
| RT | - Right |
| SERR | - Serrated |
| SHCS | - Socket Head Cap Screw |
| SHSS | - Socket Head Set Screw |
| SN | - Serial Number or Slotted Nut |
| SQ | - Square |
| T | - Tooth or Teeth |
| TFS | - Thread Forming Screw |
| THMS | - Truss Head Machine Screw |
| THRD | - Thread |
| WLDMT | - Weldment |
| # | - Number |
|  | - Torque required in foot-pounds |

TABLE OF CONTENTS

| | |
|---|--------------------|
| Introduction | Inside Front Cover |
| Decal Locations | 2-5 |
| Door, Apron Drive & Idler Assembly | 6-9 |
| Box Components | 10-13 |
| Chassis Components | 14-15 |
| Lights & Tie Down Kit | 16 |
| Auger Unit | 17 |
| Hydraulics | 18-19 |
| Options (Deflector) | 20 |
| Alphabetical Index | 21 |
| Numerical Index | 22-23 |
| Notes | 24 |
| Standard Hardware Torque Specifications | Inside Back Cover |

DECAL LOCATIONS

GENERAL INFORMATION

Decal location information is provided to assist in the proper selection and application of new decals, in the event the original decals become damaged or the machine is repainted. Refer to the listing for the illustration reference number, part number, description and quantity of each decal provided in the kit. Refer to the appropriate illustrations for replacement locations.

NOTE: Refer to the *SAFETY* chapter of the *Operator's Manual* for the specific information provided on the various safety decals furnished in the decal kits.

To ensure proper selection of the correct replacement decals, compare the various location photographs to your machine before starting to refinish the unit. Then circle each pictured decal (applicable to your machine) while checking off its part number in the listing. After you have verified all the decals needed for replacement, place any unneeded decals aside for disposal.

NEW DECAL APPLICATION

Surfaces **MUST** be free from dirt, dust, grease and other foreign material before applying the new decal. To apply, remove the smaller portion of the decal backing paper and apply this part of the exposed adhesive backing to the clean surface while maintaining proper position and alignment. Peel the other portion of the backing paper off slowly while applying hand pressure to smooth out decal surface.



CAUTION

ALWAYS observe safety precautions on decals. If decals become damaged, or if the unit is repainted, replace the decals. If repainting, **BE SURE** that **ALL** decals from the kits that apply to your machine are affixed to your unit.

PAINT NOTICE

Use this list to order paint for refinishing:
906315 One Gal. AG Red
902872 One Qt. Light Grey
906316 6 (12 oz. Spray Cans) AG Red
902874 6 (12 oz. Spray Cans) Light Grey

The decal set number for the 1840 Forage Box is 170508. The set includes the following:

| Ref. Part No. | Description & Quantity |
|---------------|--|
| 1 - 122616 | Decal - GEHL |
| 2 - 170319 | 1840 Label (Both Sides) |
| 3 - 170356 | Decal - GEHL (Both Sides) |
| 4 - 170355 | Decal - FORAGE MAX (Both Sides) |
| 5 - 093444 | WARNING - Moving Parts (6 Places-Both Sides) |
| 6 - 145217 | Amber Reflector (6 Places-Both Sides) |
| 7 - 163957 | WARNING - Do Not Remove Shields (2 Places) |
| 8 - 093367 | WARNING - Read Operator's Manual |
| 9 - 170532 | WARNING - Do Not Go Near Leaks |
| 10 - 093373 | WARNING - Before Inspecting |
| 11 - 119661 | Decal - GEHL |
| 12 - 145216 | Red Reflector (2 Places) |
| 13 - 170520 | WARNING - Do Not Operate |
| 14 - 093366 | Decal - Manual Location |

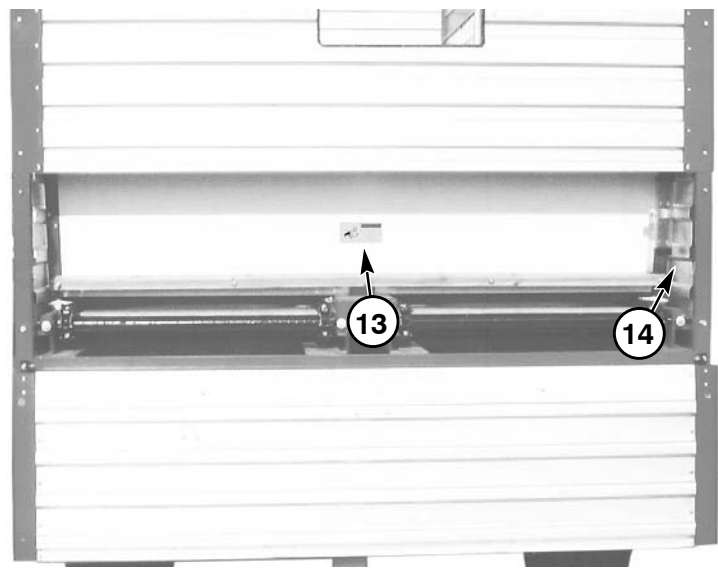
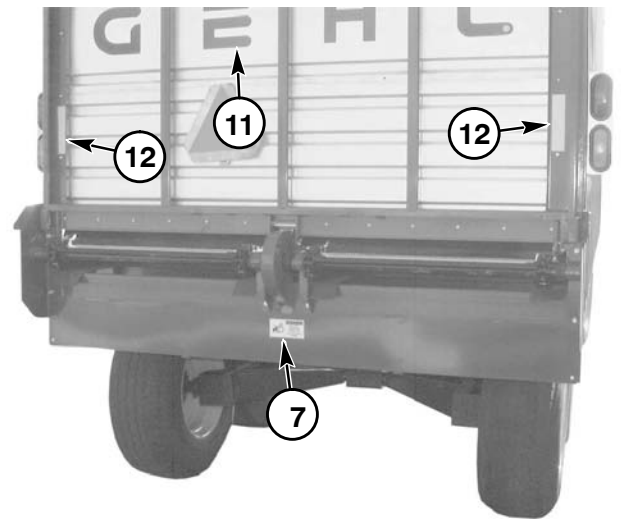
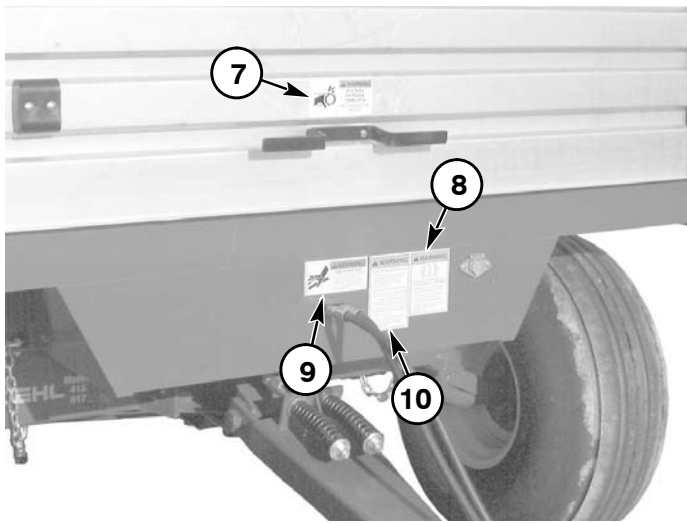
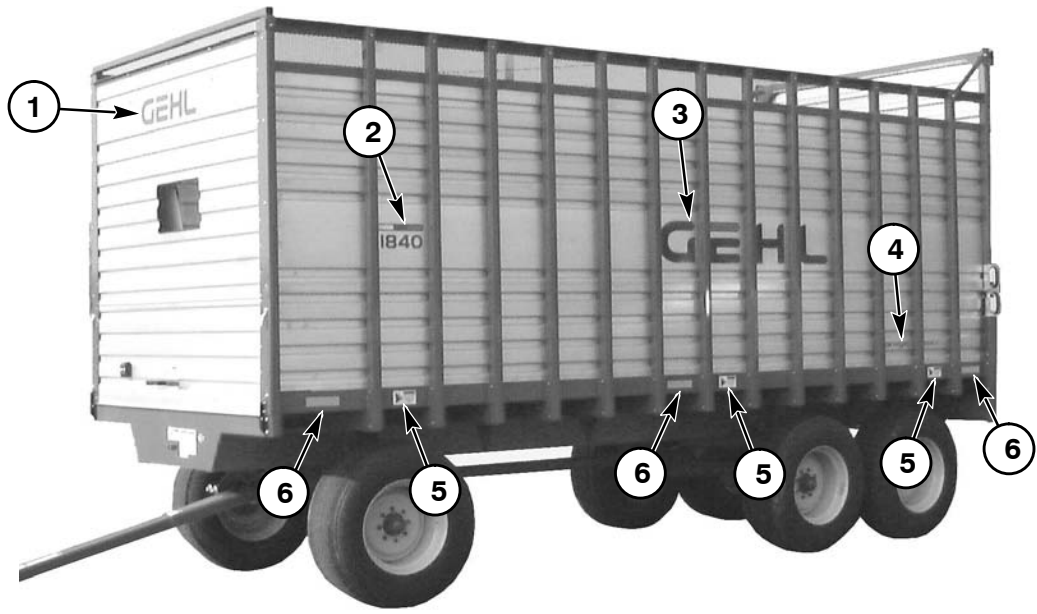

Thanks for your reading.

Please click here to download complete manual instantly.

And can also choose other manuals.

Feel free --->write to me with any questions.

Our service email:

manuals007@hotmail.com