

Form No.  
908045  
Revision B

# 1410

## Manure Spreader

### Mechanical & Hydraulic Drive



## PARTS MANUAL

**GEHL® AGRICULTURE**

## Introduction

When ordering service parts, specify the correct part number, full description, quantity required, the unit model number and serial number. For your safety and continued proper operation, use only genuine GEHL service parts.

The Manure Spreader model and serial numbers for this unit are on a decal located on the left side of the main frame at the front left corner of the box. “Right” and “left” are determined from a position standing behind the Manure Spreader.

GEHL Company reserves the right to make changes or improvements in the design or construction of any part of the unit without incurring the obligation to install such changes on any previously delivered units.

**NOTE:** *On original tire replacement, company policy prohibits the sale of replacement tires for all GEHL machinery. Replacement wheel sets are available and tire size information is called out with the wheel sets to facilitate replacement tire selection. ALL REPLACEMENT TIRES MUST BE PURCHASED LOCALLY.*

Refer to the abbreviations table located on this page for the various fastener descriptions. Standard attaching hardware torque values are also provided on the inside back cover.

In the exploded view parts list, Reference Numbers may have additional information following the Reference Number.

A tear drop symbol will indicate an application of a “wet” product such as oil, and the number inside the tear drop will correspond to the description in the Parts List.

Also, a number inside a hexagon will be the torque value required, in foot-pounds, on the associated Reference Number. Items shown in the parts list that do not have Reference Numbers are shown for reference purposes only and are NOT available for purchase.

Unless otherwise specified, all capscrews or bolts are Grade 5, cadmium or zinc plated; hexagon nuts for Grade 5 capscrews or bolts are Grade B; hexagon nuts for other capscrews or bolts are Grade A.

**NOTE:** *The following abbreviations may be used herein:*

AR	- As Required
ASSD	- Assembled
ASSY	- Assembly
CB	- Carriage Bolt
CCW	- Counterclockwise
CP	- Cotter Pin
CS	- Capscrew (Hexagon Head)
CTR	- Center
CW	- Clockwise
DEG	- Degree
DIA	- Diameter
FCS	- Flanged Capscrew
FHMS	- Flat Head Machine Screw
FL	- Flanged
FLN	- Flanged Lock Nut (Hexagon)
FLS	- Flanged Lock Screw (Hexagon)
FW	- Flat Washer
GA	- Gauge
GR	- Grade
HD	- Hard or Head
HN	- Hex Nut
INCL	- Includes
JT	- Joint
LG	- Large
LH	- Left Hand
LN	- Lock Nut
LW	- Lock Washer
M	- Metric
MM/mm	- Millimeter
NF	- National Fine
NS	- Not Serviced
PB	- Plow Bolt
PTO	- Power Take Off
RH	- Right Hand
RHMS	- Round Head Machine Screw
RPM	- Revolutions Per Minute
RT	- Right
SERR	- Serrated
SHCS	- Socket Head Capscrew
SHSS	- Socket Head Set Screw
SN	- Serial Number or Slotted Nut
SQ	- Square
T	- Tooth or Teeth
TFS	- Thread Forming Screw
THMS	- Truss Head Machine Screw
THRD	- Thread
WLDMT	- Weldment
#	- Number
	- Torque Required in foot-pounds
	- Indicates a Fluid Application

# TABLE OF CONTENTS

Introduction .....	Inside Front Cover
Table of Contents .....	1
Decal Locations .....	2-3
PTO .....	4-5
Hitch Frame & Jack .....	6-7
Main Frame, Floor, Axle Beam & Hub Assembly .....	8-9
Single Apron & Apron Chains .....	10-11
Double Apron Shafts .....	12-13
Apron Controls .....	14-15
Apron Control Hydraulic Cylinder .....	16-17
Front Drive .....	18-19
Apron & Beater Drive (Mechanical Drive) .....	20-23
Beater Drive Gearbox .....	24-25
Apron Drive Gearbox (Mechanical Drive) .....	26-27
Hydraulic Apron Drive - Flow Control Valve .....	28-29
Hydraulic Apron Drive - Rear Drive .....	30-31
Hydraulic Drive Motor .....	32-33
Flow Control Valve .....	34-35
Apron Drive Gearbox (Hydraulic Drive) .....	36-37
Front Endgate .....	38-39
Front & Side Shields .....	40-41
Side Sheets & Rear Supports .....	42-43
Beater .....	44-45
Upper Beater .....	46-47
Litter Pan .....	48-49
Hydraulic Endgate .....	50-51
Endgate Hydraulic Cylinder .....	52-53
Options & Accessories .....	54-58
Transport Lights .....	54-57
Safety Chain .....	58
Alphabetical Index .....	59
Numerical Index .....	60-67
Hydraulic Fitting Torque Data .....	68
Standard Hardware Torque Specifications .....	Inside Back Cover

# DECAL LOCATIONS

## GENERAL INFORMATION

Decal location information is provided to assist in the proper selection and application of new decals, in the event the original decals become damaged or the machine is repainted. Refer to the listing for the illustration reference number, part number, description and quantity of each decal provided in the kit. Refer to the appropriate illustrations for replacement locations.

**NOTE:** Refer to the *SAFETY* chapter for specific information on the safety decals in the decal kits.

To ensure proper selection for correct replacement decals, compare all of the various close-up location illustrations of the machine **BEFORE** starting to refinish the unit. Then circle each pictured decal, applicable to your machine, while checking off its part number in the listing. After verifying all the decals needed for replacement, set aside any unneeded decals for disposal.

## NEW DECAL APPLICATION

Surfaces **MUST** be free from dirt, dust, grease and other foreign material before applying the new decal. To apply a solid-formed decal, remove the smaller portion of the decal backing paper and apply this part of the exposed adhesive backing to the clean surface while maintaining proper position and alignment. Slowly peel off the other portion of the backing paper while applying hand pressure to smooth out the decal surface.



## WARNING

**ALWAYS** observe safety precautions listed on decals. If decals become damaged, or if the unit is repainted, replace the decals. If repainting, **BE SURE** that **ALL** decals from the kits that apply to your machine are affixed to your unit.

The decal kit part number for the 1410 Manure Spreader is 143383. The kit includes the following:

Ref. No.	Part No.	Description & Quantity
01	145216	Red Reflector Strip (2 Places)
02	145217	Amber Reflector Strip (3 Places)
03	091444	DANGER - Rotating Component
04	093020	Lubrication Symbol
05	093366	IMPORTANT - Store Manual Here
06	093367	WARNING - Owner's Responsibility & Read Manual
07	093373	WARNING - General Safety Precautions
08	093457	WARNING - Keep Door Closed (2 Places) (3 Places on units with Upper Beater)
09	094913	GEHL 3-1/4 x 15-1/4"
10	142984	540 RPM
	143002	1000 RPM
11	142985	Keep Well Lubricated
12	143000	Indicator Arrow
13	143001	150 ft-lb Wheel Bolt torque (HD Wheels)
14	143003	Apron Speed Selector Control (Hydraulic Apron Drive Models)
15	143004	Apron Speed Selector Control (Standard PTO Apron Drive Models)
16	143005	DANGER - NO RIDERS
17	143008	120 ft-lb Wheel Bolt torque (Std Wheels)

The following decals are not included in the above kit but may be needed to complete the decaling of your unit.

18	122617	GEHL 6.9 x 32-1/2" (2 Places on 1410) (Both Sides)
19	143243	1410 (2 Places)

### PAINT NOTICE

Use this list to order paint for refinishing:

906315	One Gal. AG Red
906324	One Qt. Light Grey
906316	6 (12 oz. Spray Cans) AG Red
906325	6 (12 oz. Spray Cans) Light Grey

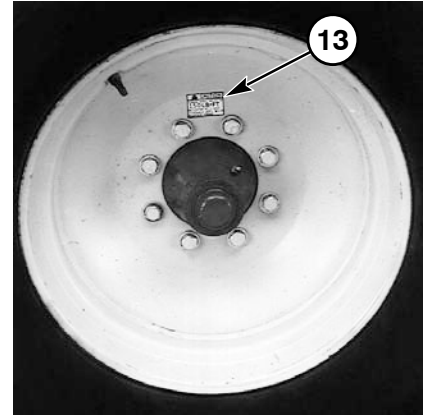
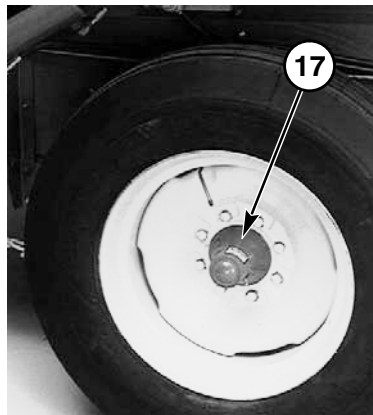
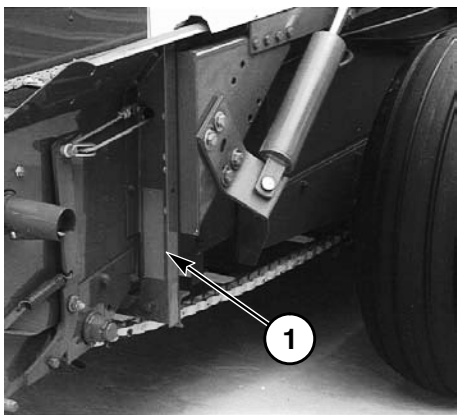
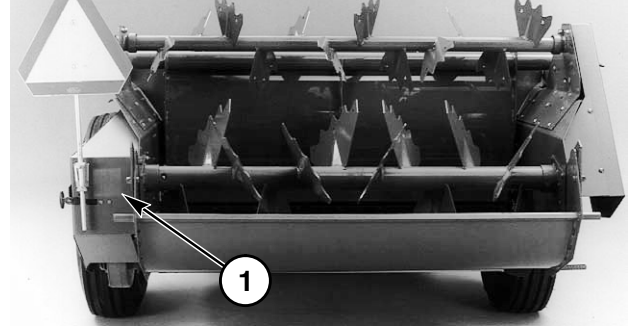
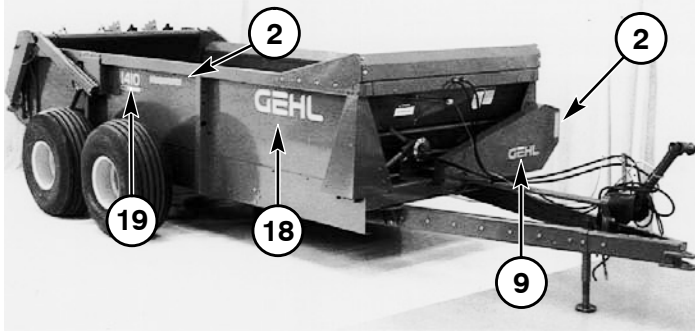
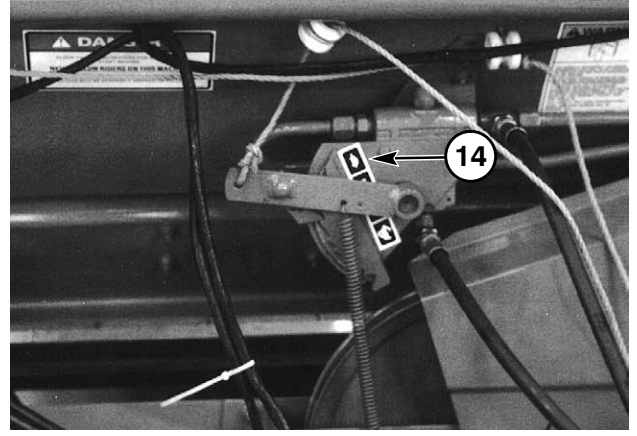
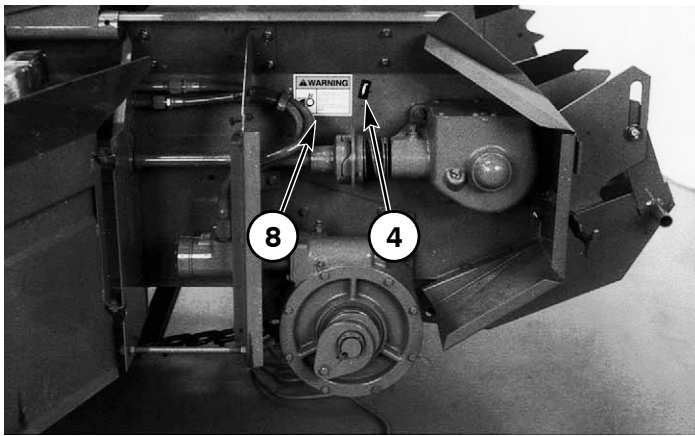
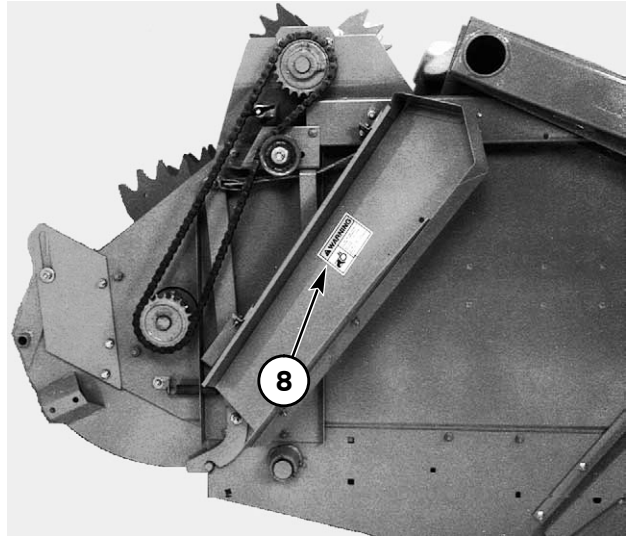
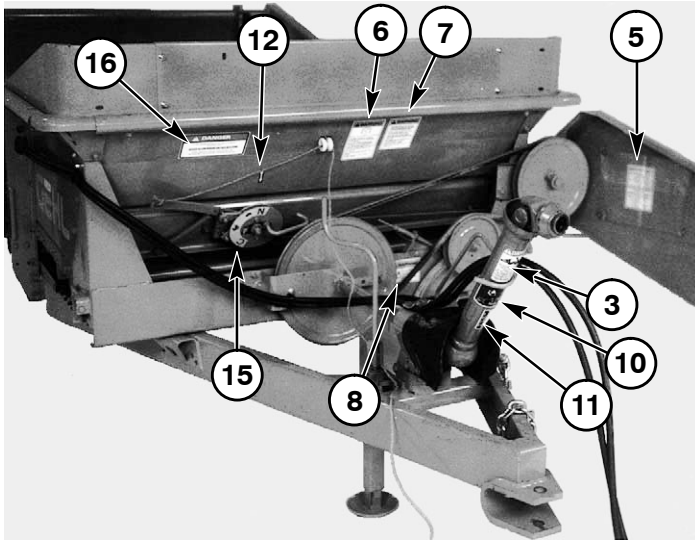

**Thanks for your reading.**

**Please click here to download complete manual instantly.**

**And can also choose other manuals.**

**Feel free --->write to me with any questions.**

**Our service email:**

**manuals007@hotmail.com**