

Form No.
907503
Revision B

1309, 1312, 1315, 1322

Scavenger[®]

Manure Spreaders

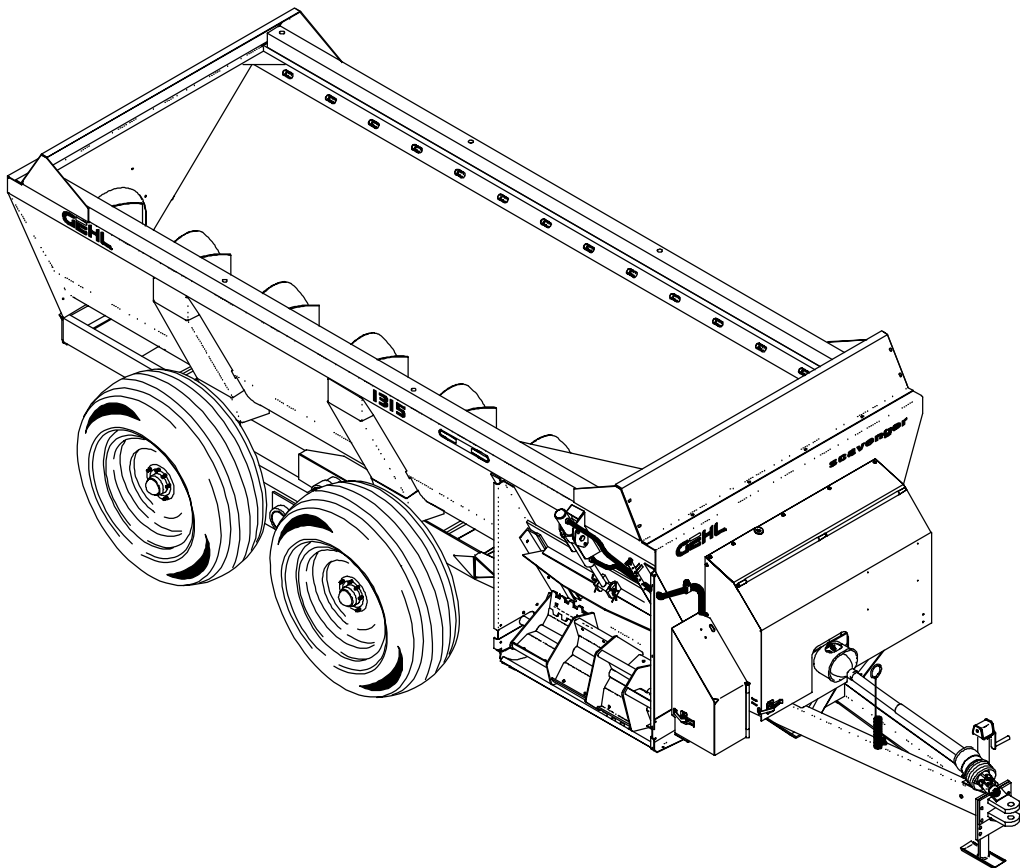

PARTS MANUAL

GEHL[®] AGRICULTURE

Introduction

When ordering service parts, specify the correct part number, full description, quantity required, the unit model number and serial number.

The Spreader model and serial numbers are on a plate located on the front, left corner of the tank. "Right" and "left" are determined from a position standing behind the Spreader and facing in the direction of travel. From this position, the expeller is on the "right" side.

GEHL Company reserves the right to make changes or improvements in the design or construction of any part of the unit without incurring the obligation to install such changes on any previously delivered units.

NOTE: *On original tire replacement, company policy prohibits the sale of replacement tires for all GEHL machinery. Replacement wheel sets are available and tire size information is called out with the wheel sets to facilitate replacement tire selection. ALL REPLACEMENT TIRES MUST BE PURCHASED LOCALLY.*

Refer to the abbreviations table located on this page for the various fastener descriptions. Standard attaching hardware torque values are also provided on the inside back cover.

Items shown in the parts list that do not have Reference Numbers are shown for reference purposes only and are NOT available for purchase.

Unless otherwise specified, all cap screws or bolts are Grade 5, cadmium or zinc plated; hexagon nuts for Grade 5 screws or bolts are Grade B; hexagon nuts for other screws or bolts are Grade A.

NOTE: *The following abbreviations may be used herein:*

ASSD	- Assembled
ASSY	- Assembly
CB	- Carriage Bolt
CCW	- Counterclockwise
CP	- Cotter Pin

CS	- Cap Screw (Hexagon Head)
CTR	- Center
CW	- Clockwise
DEG	- Degree
DIA	- Diameter
FCS	- Flanged Cap Screw
FHMS	- Flat Head Machine Screw
FL	- Flanged
FLN	- Flanged Lock Nut (Hexagon)
FLS	- Flanged Lock Screw (Hexagon)
FW	- Flat Washer
GA	- Gauge
GR	- Grade
HD	- Hard or Head
HN	- Hex Nut
INCL	- Includes
JT	- Joint
LFLN	- Large Flanged Lock Nut (Hexagon)
LG	- Large
LH	- Left Hand
LN	- Lock Nut
LT	- Left
LW	- Lock Washer
M	- Metric
MM/mm	- Millimeter
NF	- National Fine
PB	- Plow Bolt
PTO	- Power Take Off
RH	- Right Hand
RHMS	- Round Head Machine Screw
RPM	- Revolutions Per Minute
RT	- Right
SERR	- Serrated
SHCS	- Socket Head Cap Screw
SHSS	- Socket Head Set Screw
SN	- Serial Number or Slotted Nut
SQ	- Square
T	- Tooth or Teeth
TFS	- Thread Forming Screw
THMS	- Truss Head Machine Screw
THRD	- Thread
WLDMT	- Weldment

TABLE OF CONTENTS

Subject	Page No.
Introduction	Inside Front Cover
Decal Locations	2-3
Auger, Liner, Slides & Hitch	4-5
Auger Drive	6-7
Expeller & Discharge Gate	8-9
Input Shaft & Expeller Drive	10-11
Hydraulics	12-15
Guards & Shields	16-17
1309 - Single Axles	18
1312 - Single Axles	19
1312 - Tandem Axles	20-21
1315 - Tandem Axles	22-23
1322 - Tandem Axles	24-25
1322 - Tandem Axles (w/Brakes)	26-27
1322 - Tandem Axles (Brake Hydraulics)	28-29
Transport Lights	30-31
Tank Repair Panels	32
Component Breakdowns	33-39
Augers	33
Hydraulic Cylinders	34
Splash Guards & Rails	35
Hitchjacks	36-37
PTO - 540 RPM (1309 & 1312, 1315)	38
PTO - 1000 RPM (1322)	39
Options & Accessories	40-43
Hydraulic Lid Kit	40-41
Safety Chains	42
Chain Oiler	43-44
Index	45
Numerical Index	46-51
Hydraulic Fitting Data	52
Standard Hardware Torque Specifications	Inside Back Cover

DECAL LOCATIONS

GENERAL INFORMATION

Decal locations information is provided to assist in the proper selection and application of new decals, in the event the original decals become damaged or the machine is repainted. Refer to the listing for the photograph reference number, part number, description and quantity of each decal provided in the kit. Refer to the appropriate photographs for replacement locations.

NOTE: Refer to the *SAFETY* chapter for information on the safety decals in the decal kit.

To ensure proper selection for correct replacement decals, compare all of the various close-up location photographs to your machine **BEFORE** starting to refinish the unit. Then circle each pictured decal (applicable to your machine) while checking off its part number in the listing. After you have verified all the decals needed for replacement, set aside unneeded decals for disposal.

NEW DECAL APPLICATION

Surfaces **MUST** be free from dirt, dust, grease and other foreign material before applying the new decal. To apply a solid-formed decal, remove the smaller portion of the decal backing paper and apply this part of the exposed adhesive backing to the clean surface while maintaining proper position and alignment. Slowly peel off the other portion of the backing paper while applying hand pressure to smooth out the decal surface.



CAUTION

ALWAYS observe safety precautions shown on decals. If decals become damaged, or if the unit is repainted, replace the decals. If repainting, **BE SURE** that **ALL** decals from the kits that apply to your machine are affixed to your unit.

PAINT NOTICE

Use this list to order paint for refinishing:

906315	One Gal. AG Red
906324	One Qt. Light Grey
906316	6 (12 oz. Spray Cans) AG Red
906325	6 (12 oz. Spray Cans) Light Grey

The decal kit number for the 1309/1312/1315/1322 Scavenger Manure Spreaders is 141263. The kit includes the following:

Ref. No.	Part No.	Description & Quantity
1	145234	SMV Decal
2	060510	Jack Storage Position
3	060511	Jack Lifting Position
4	145216	Red Reflector Strip (2 Places)
5	091444	DANGER - Rotating Drive Line
6	093020	Lubrication Symbol (7 Places W/Tandem Axles, 5 Places W/Single Axles)
7	093208	Rotating Spiral Symbol
8	093366	IMPORTANT - Store Manual Here
9	093367	WARNING - Owner's Responsibility & Read Manual
10	093373	WARNING - General Safety Precautions
11	093457	WARNING - Keep Door Closed (2 Places)
12	093466	WARNING - 540 RPM Operation ONLY
	093465	WARNING - 1000 RPM Operation ONLY
13	093638	DANGER - Rotating Expeller (2 Places)
14	093653	WARNING - Rotating Drive Line
15	093639	DANGER - Manure Gas
16	094912	Colorbar (2 Places)
17	094913	GEHL (4 Places - 1309, 1312, 1315, 2 Places - 1322)
18	094951	Made in USA
19	115628*	Decal - All Model Numbers (2 Places)
20	120399	DANGER - Rotating Auger (3 Places)
21	120740	Scavenger Decal (2 Places, All Models)
22	141249	Decal - Patent
23	145217	Amber Reflector Strip (2 Places - 1309, 4 Places - 1312, 1315, 5 Places - 1322)
24	122736	GEHL (2 Places - 1322)

* 115628 model number decal covers all Scavenger model numbers.

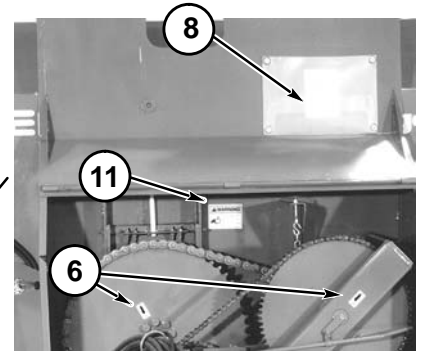
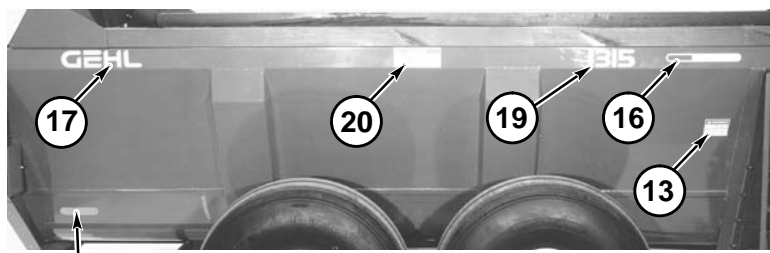

23
Both Sides

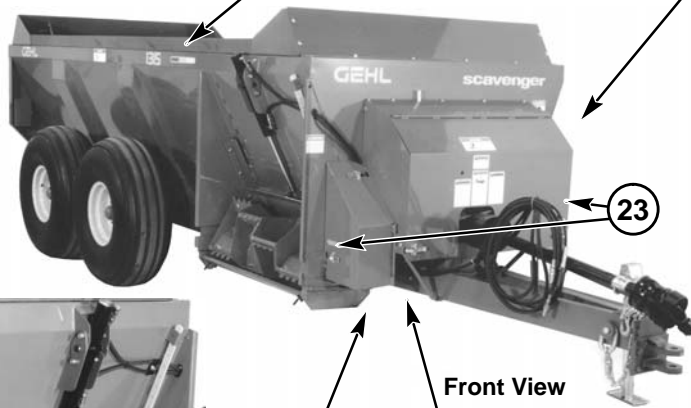

Front View

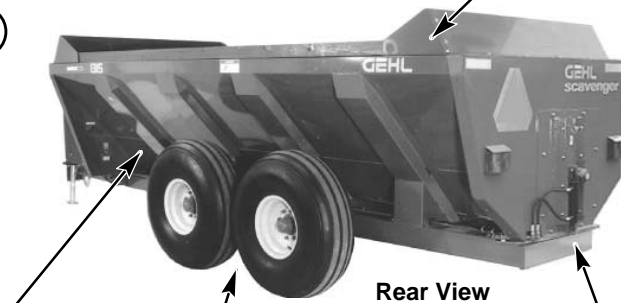
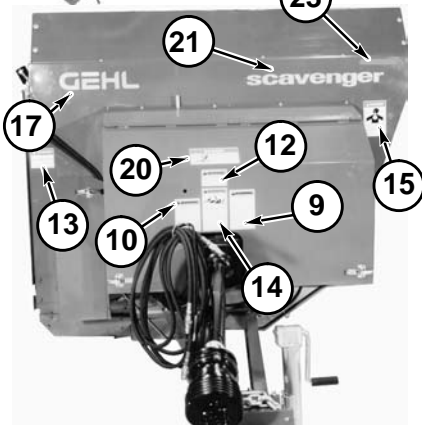
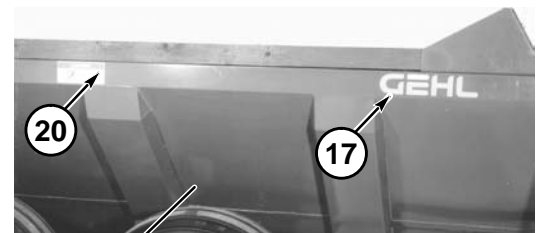
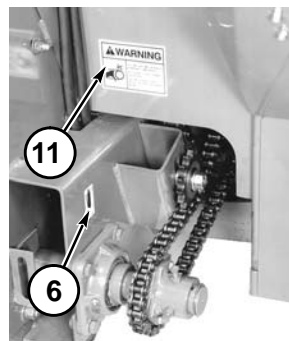
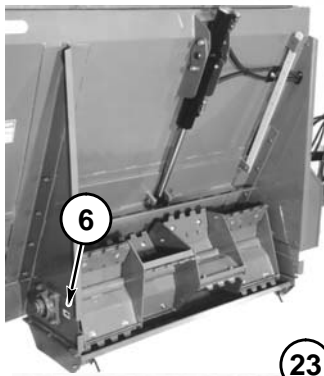
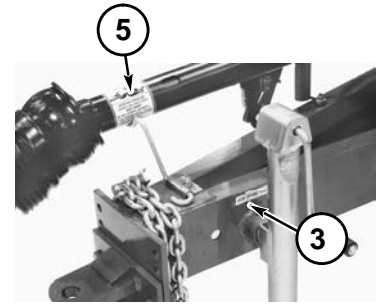

Rear View

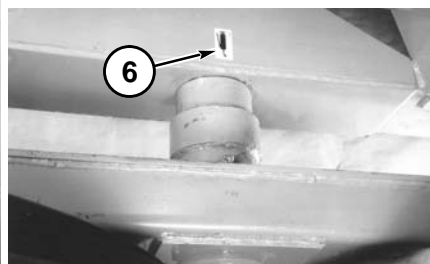
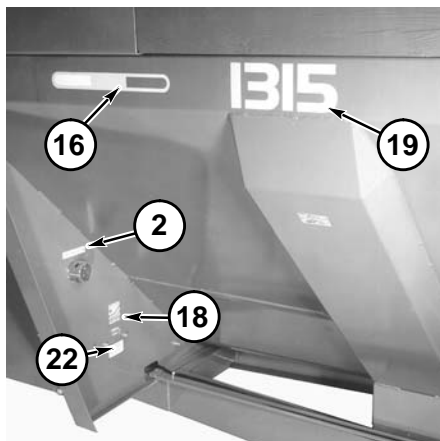

Tandem Axles Only

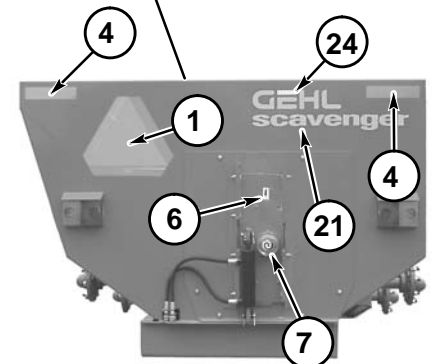

Thanks for your reading.

Please click here to download complete manual instantly.

And can also choose other manuals.

Feel free --->write to me with any questions.

Our service email:

manuals007@hotmail.com