

CAPACITIES AND SPECIFICATIONS

GLC050LX [A967];
GLP/GDP20-25LX (GLP/GDP050LX) [A974]

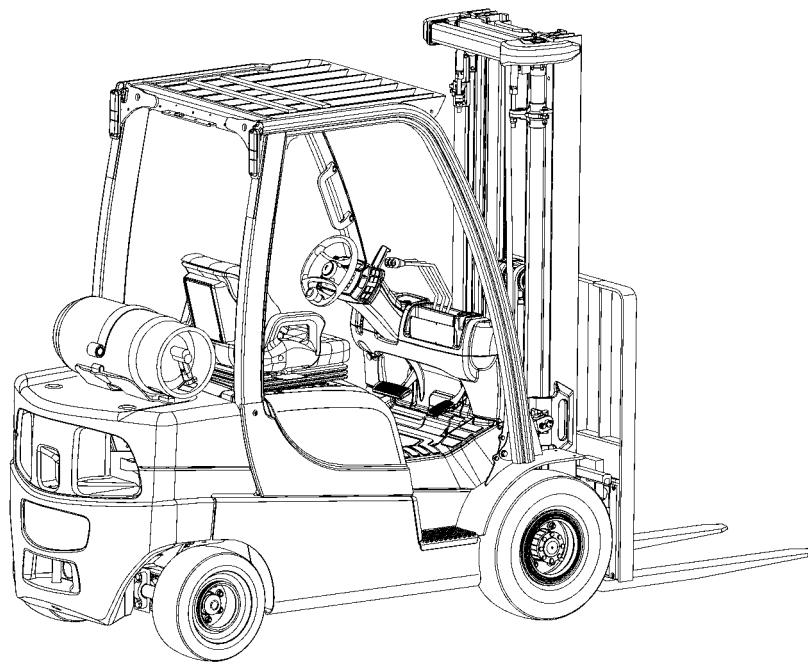

SAFETY PRECAUTIONS

MAINTENANCE AND REPAIR

- The Service Manuals are updated on a regular basis, but may not reflect recent design changes to the product. Updated technical service information may be available from your local authorized Yale® dealer. Service Manuals provide general guidelines for maintenance and service and are intended for use by trained and experienced technicians. Failure to properly maintain equipment or to follow instructions contained in the Service Manual could result in damage to the products, personal injury, property damage or death.
- When lifting parts or assemblies, make sure all slings, chains, or cables are correctly fastened, and that the load being lifted is balanced. Make sure the crane, cables, and chains have the capacity to support the weight of the load.
- Do not lift heavy parts by hand, use a lifting mechanism.
- Wear safety glasses.
- DISCONNECT THE BATTERY CONNECTOR before doing any maintenance or repair on electric lift trucks. Disconnect the battery ground cable on internal combustion lift trucks.
- Always use correct blocks to prevent the unit from rolling or falling. See HOW TO PUT THE LIFT TRUCK ON BLOCKS in the **Operating Manual** or the **Periodic Maintenance** section.
- Keep the unit clean and the working area clean and orderly.
- Use the correct tools for the job.
- Keep the tools clean and in good condition.
- Always use **YALE APPROVED** parts when making repairs. Replacement parts must meet or exceed the specifications of the original equipment manufacturer.
- Make sure all nuts, bolts, snap rings, and other fastening devices are removed before using force to remove parts.
- Always fasten a DO NOT OPERATE tag to the controls of the unit when making repairs, or if the unit needs repairs.
- Be sure to follow the **WARNING** and **CAUTION** notes in the instructions.
- Gasoline, Liquid Petroleum Gas (LPG), Compressed Natural Gas (CNG), and Diesel fuel are flammable. Be sure to follow the necessary safety precautions when handling these fuels and when working on these fuel systems.
- Batteries generate flammable gas when they are being charged. Keep fire and sparks away from the area. Make sure the area is well ventilated.

NOTE: The following symbols and words indicate safety information in this manual:



WARNING

Indicates a hazardous situation which, if not avoided, could result in death or serious injury.



CAUTION

Indicates a hazardous situation which, if not avoided, could result in minor or moderate injury and property damage.

On the lift truck, the WARNING symbol and word are on orange background. The CAUTION symbol and word are on yellow background.

TABLE OF CONTENTS

Lift Truck Lifting Capacity	1
Counterweight Weights	1
Tire Sizes	1
Capacities	2
Electrical System	4
Transmission Oil Pressures	5
Hydraulic System Relief Pressures	6
Steering System	6
Stall Speeds	6
Mast Speeds	7
Tilt Angles	8
Front End Equipment	8
Mast Creep	8
Engine Specifications	9
Torque Specifications	10
Frame	10
Mast	10
Steering System	10
Drive Axle	10
Transmission	11
Engine - Mazda LPG FE and F2.....	11

This section is for the following models:

(GLC050LX) [A967];
GLP/GDP20-25LX (GLP/GDP050LX) [A974]

Yale[®] 

Lift Truck Lifting Capacity

Model	Weight
GLC050LX (A967)	2268 kg (5000 lb)
GLP/GDP20-25LX (GLP/GDP050LX) (A974)	2268 kg (5000 lb)
NOTE: Load center at 500 mm (24 in.).	

Counterweight Weights





Model	Weight
GLC050LX (A967)	1401 kg (3088 lb)
GLP/GDP20LX (A974)	950 kg (2094 lb)
GLP/GDP25LX (GLP/GDP050LX) (A974)	1230 kg (2712 lb)
GLP/GDP050LX (A974) Optional Counterweight	1335 kg (2943 lb)

Tire Sizes

Truck	Drive Tires	Steer Tires
GLC050LX (A967)	21 x 7 x 15	16 x 5 x 10.5
GLP/GDP20-25LX (A974)	6.50 x10 Solid SIT	18.7-8 Solid SIT
GLP/GDP050LX (A974)	6.50 x 10-12PR Wide Tread Width Solid Pneumatic	5.00 x 8-10 PR Wide Tread Width Solid Pneumatic
GLP/GDP050LX (A974)	6.50 x 10 Single Tread Width Solid Pneumatic	18 x 7-8 Single Tread Width Solid Pneumatic
GLP/GDP050LX (A974)	23 x 10-12PR Wide Tread Width Solid Pneumatic (Optional)	

Capacities

Item	Quantity	Specifications
Fuel Capacity		
LPG	38.4 liter (10.1 gal) 15.2 kg (33.5 lb) Full	LPG-HD 5, HD 10
Diesel	38.4 liter (10.1 gal)	Diesel No. 2
Engine Oil		
Mazda FE	3.9 liter (4.1 qt)	-7°C (-20°F) and below SAE 5W-20 16°C (60 °F) and below SAE 5W-30 -18°C (0°F) and above SAE 10W-30 API SM IL- SAC GF4 SAE J2362
Mazda F2	4.2 liter (4.4 qt)	-7°C (-20°F) and below SAE 5W-20 16°C (60 °F) and below SAE 5W-30 -18°C (0°F) and above SAE 10W-30 API SM IL- SAC GF4 SAE J2362
Yanmar 2.6L	10.2 liter (10.8 gal)	20°C (68°F) and over SAE 40 10 to 30°C (50 to 86°F) SAE 30 0 to 20°C (32 to 68°F) SAE 20 -16 to 40°C (3 to 104°F) SAE 15W-40 -20 to 30°C (-4 to 86°F) SAE 10W-30 -10 to 10°C (14 to 50°F) SAE 20W -20 to 10°C (-4 to 50°F) SAE 10W
Cooling System		

Item	Quantity	Specifications
Mazda FE and F2	11.0 liter (11.6 qt)	 CAUTION Additives may damage the cooling system. Before using additives, contact your local Yale dealer. Use Ethylene Glycol Boron-free Antifreeze. Purchase a pre-diluted 50/50 solution; or mix 50% concentrate with 50% distilled water or deionized water.
Yanmar 2.6L Diesel	11.5 liter (12.1 qt)	 CAUTION Additives may damage the cooling system. Before using additives, contact your local Yale dealer. Use Ethylene Glycol Boron-free Antifreeze. Purchase a pre-diluted 50/50 solution; or mix 50% concentrate with 50% distilled water or deionized water.
Hydraulic Tank Oil Capacity		
GLC050LX (A967)	29.9 liter (31.6 qt) Drain and Fill	 CAUTION Additives may damage the hydraulic system. Before using additives, contact your local Yale dealer. ISO VG-46 Hydraulic Oil -15°C (5°F) and above
GLP/GDP20-25LX (GLP/GDP050LX) (A974)	39.2 liter (41.4 qt) Drain and Fill	 CAUTION Additives may damage the hydraulic system. Before using additives, contact your local Yale dealer. ISO VG-46 Hydraulic Oil -15°C (5°F) and above
Transmission Oil		
Single Speed Powershift Transmission	13 liter (14.0 qt)	John Deere JDM J20C
Brake Oil (Master Cylinder)	0.25 liter (0.26 qt)	SAE J-1703 (DOT 3)
Differential and Drive Axle Oil	5.0 liter (5.3 qt)	SAE 80W-90 or 85W-140

Electrical System

Item	Mazda FE LPG	Mazda F2 LPG	Yanmar 2.6L Diesel
Battery	12-volt, negative ground	12-volt, negative ground	12-volt, negative ground
Ignition Timing			
LPG (With ECU in Set Mode)	BTDC 6° (Orange Timing Mark)	BTDC 6° (Orange Timing Mark)	N/A
Diesel	N/A	N/A	Preset @ 4° ATDC
Alternator Output	14 Volts	14 Volts	13.5Volts
Idle	16 amps @ 800 rpm	21 amps @ 800 rpm	14 amps @ 825 rpm
High Idle	47 amps @ 2400 rpm	49 amps @ 2600 rpm	55 amps @ 2400 rpm
Spark Plug Type	Nippon Denso W9EXR-U	Nippon Denso W9EXR-U	N/A
Spark Plug Size	M14 x 1.25	M14 x 1.25	N/A
Spark Plug Gap	0.8 +0.0/-0.1 mm (0.032 +0.0/-0.0040 in.)	0.8 +0.0/-0.1 mm (0.032 +0.0/-0.0040 in.)	N/A

Transmission Oil Pressures

1-Speed Transmission - Aluminum Housing All Pressures at 2000 rpm and Oil at 18 to 65°C (65 to 150°F)				
Port 1 Transmission Pump		Port 2	Port 3	Port 5
***Low Pressure	High Pressure	Reverse Clutch	Forward Clutch	Lubrication
1089 ±69* kPa (158 ±10 psi)	1241 ±138* kPa (180 ±20 psi)	983 ±58** kPa (142.5 ±8.5 psi)	983 ±58** kPa (142.5 ±8.5 psi)	62 ±41 kPa (9 ±6 psi)

(A)

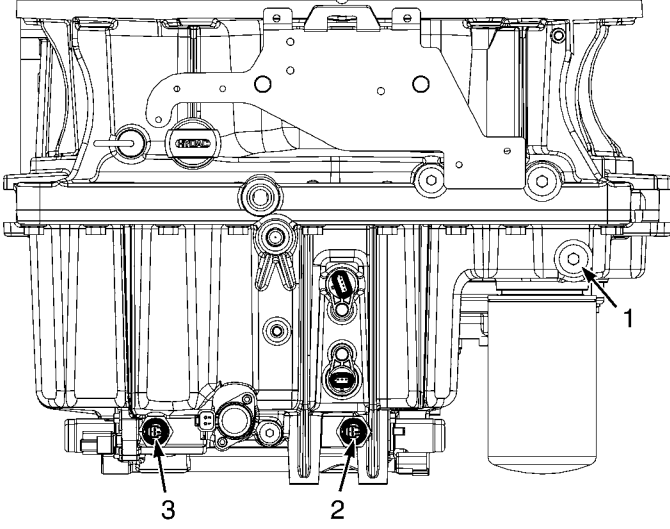

A. TOP VIEW

(B)

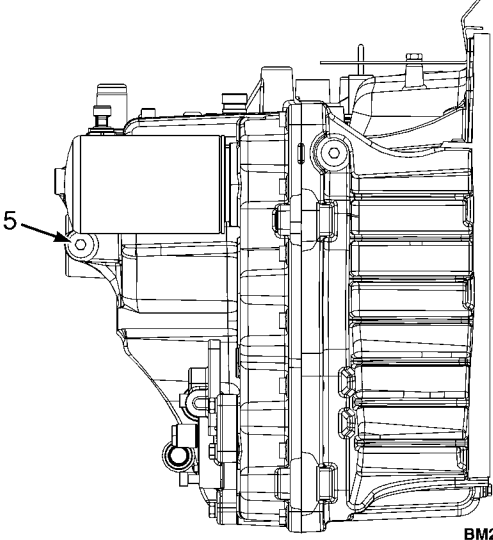

B. RIGHT SIDE VIEW

BM210876

*Relief Pressure **Clutch pack pressure difference between the forward and reverse packs cannot exceed manufacturing limit of 48 kPa (7 psi) or service limit of 70 kPa (10 psi). ***Low pressure at 800 rpm and oil at 27 to 32°C (80 to 90°F).

Hydraulic System Relief Pressures

Item	Specification
Oil Temperature for Setting Relief Pressure	50 to 65°C (122 to 149°F)
Primary Relief Valve Pressure (High Idle)	21.4 ±0.48 MPa (3103 ±70 psi)
Secondary Relief Valve Pressure (High Idle)	18.0 MPa (2610 psi)

Steering System

Item	Quantity	
Oil Temperature for Setting Relief Pressure	50 to 65°C (122 to 149°F)	
Steering Relief Pressure at 800 rpms	11.0 ±0.3 MPa (1595 ±43.5 psi)	
Steering Cylinder Stroke (Each Side)	135.2 mm (5.3 in.)	
Inside Steering Tire Angle	82.3°	
Number of Turns Lock to Lock	3.50	
Turning Radius (±50 mm NO LOAD)	Outside	Inside
GLC050LX (A967)	2062	75
GLP/GDP20-25LX (GLP/GDP050LX) (A974)	2236	103

Stall Speeds

Engine	Transmission	New Engine	Broken-In Engine (30 hrs)
Mazda FE LPG	Single Speed Powershift	1820 rpm*	1865 rpm*
Yanmar 2.6L Diesel	Single Speed Powershift	1752 rpm*	1845 rpm*
Mazda F2 LPG	Single Speed Powershift	2010 rpm*	2050 rpm*
		*±100 rpm	

Mast Speeds

NOTE: Lift speed is measured in meters/sec (inch/sec) at governed engine RPM with full open valve and 65°C (149°F) oil temperature.

Lowering speed is measured in meters/sec (inch/sec) with full open valve and 65°C (149°F) oil temperature.

Plus or minus 10% acceptable lifting or lowering.

Engine	Model	Mast	Lowering M/Sec (Inch/Sec)		Lifting M/Sec (Inch/Sec)	
			No Load	Rated Load	No Load	Rated Load
Mazda FE LPG	GLC050LX (A967) and GLP20-25LX (A974)	2-Stage LFL	0.48 (18.9)	0.51 (20.1)	0.54 (21.3)	0.46 (18.1)
	GLC050LX (A967)	3-Stage FFL	0.42 (16.5)	0.49 (19.3)	0.50 (19.7)	0.43 (16.9)
	GLP20-25LX (GLP050LX) (A974)	3-Stage FFL	0.42 (16.5)	0.49 (19.3)	0.50 (19.7)	0.42 (16.5)
Yanmar 2.6L Diesel	GDP20-25LX (A974)	2-Stage LFL	0.47 (18.5)	0.51 (20.1)	0.58 (22.8)	0.57 (22.4)
Mazda F2 LPG	GLC050LX (A967) and GLP20-25LX (A974)	2-Stage LFL	0.48 (18.9)	0.51 (20.1)	0.59 (23.2)	0.51 (20.1)
	GLC050LX (A967)	3-Stage FFL	0.42 (16.5)	0.49 (19.3)	0.55 (21.7)	0.47 (18.5)
	GLP20-25LX (GLP050LX) (A974)	3-Stage FFL	0.42 (16.5)	0.49 (19.3)	0.55 (21.7)	0.47 (18.5)

Tilt Angles

Lift truck should be on level ground and in unloaded condition.

Mast Type	Model	Forward	Tolerance	Back	Tolerance
3-Stage FFL	GLC050LX (A967)	10°	+1°, -0.5°	5°	+0°, -0.5°
3-Stage FFL	GLC050LX (A967)	5°	+1°, -0.5°	5°	+0°, -0.5°
3-Stage FFL	GLP/ GDP20-25LX (GLP/ GDP050LX) (A974)	5°	+1°, -0.5°	5°	+0°, -0.5°
2-Stage LFL	GLP/ GDP20-25LX (A974)	5°	+1°, -0.5°	5°	+0°, -0.5°

Front End Equipment

MAST CREEP

NOTE: Mast should be 90° vertical prior to test.

Measure with rated load at 2.5 m (8.0 ft) high and with the lift, tilt, and auxiliary control levers in neutral position.

Hydraulic Oil Temperature		Maximum Vertical Creep at Carriage		Maximum Tilt Creep		
				Mast Angle	Cylinder Stroke	
°C	°F	mm/Min	in./Min	Deg./Min	mm/Min	in./Min
20	68	2.2	0.086	0.10	0.90	0.035
30	86	3.3	0.130	0.15	1.32	0.052
40	104	6.3	0.247	0.29	2.48	0.098
50	122	10.0	0.394	0.47	3.99	0.157
60	140	14.6	0.575	0.68	5.74	0.266

Engine Specifications

Item	Mazda FE	Mazda F2	Yanmar 2.6L
No. of Cylinders	4 Inline	4 Inline	4 Inline
Firing Order	1-3-4-2	1-3-4-2	1-3-4-2
Bore	86 mm (3.4 in.)	86 mm (3.4 in.)	92 mm (3.62 in.)
Stroke	86 mm (3.4 in.)	94 mm (3.7 in.)	100 mm (3.94 in.)
Displacement	1998 cc	2184 cc	2659 cc
Horsepower/rpm	30.2 @ 2400 rpm	40.1 @ 2700 rpm	45.1 @ 2400 rpm
Engine Timing	(With ECU in Set Mode) BTDC 6° (Orange Timing Mark)	(With ECU in Set Mode) BTDC 6° (Orange Timing Mark)	Preset @ 4° ATDC
Compression Ratio			
LPG	9.3:1	9.9:1	21.5:1
Compression Pressure			
Oil Pressure	1131 kPa (164 psi) @ 270 rpm	1131 kPa (164 psi) @ 270 rpm	2840 to 3040 kPa (412 to 441 psi) @ 250 rpm
Valve Clearance			
Intake	0.15 mm (0.006 in.) Cold	0.15 mm (0.006 in.) Cold	0.20 ±0.05 mm (0.008 ±0.002 in.) Cold
Exhaust	0.35 mm (0.014 in.) Cold	0.35 mm (0.014 in.) Cold	0.20 ±0.05 mm (0.008 ±0.002 in.) Cold
Idle Speed (No Load)	800 ±25 rpm	800 ±25 rpm	825 ±25 rpm
Governed Speed High Idle (No Load)	2400 ±25 rpm	2600 ±25 rpm	2400 ±25 rpm
Thermostat Range			
START TO OPEN	82 ±1.5°C (180 ±35°F)	82 ±1.5°C (180 ±35°F)	71 ±2°C (160 ±36°F)
FULL OPEN	95 ±1.5°C (203 ±35°F)	95 ±1.5°C (203 ±35°F)	85 ±2°C (185 ±36°F)
Cooling System Pressure	103 kPa (15 psi)	103 kPa (15 psi)	103 kPa (15 psi)

Torque Specifications

FRAME

Overhead Guard Mount Capscrews

66 N•m (49 lbf ft)

Cowl-to-Overhead Guard Legs

66 N•m (49 lbf ft)

Steering Wheel Nut

40 to 54 N•m (30 to 40 lbf ft)

Counterweight Capscrew (Counterweight To Lower Frame)

555 N•m (409 lbf ft)

MAST

Mast Mounting Capscrews

Mast to Drive Axle Retainer Caps 115 N•m (85 lbf ft)

Tilt Cylinder Adjust 90 N•m (66 lbf ft)

Load Backrest to Carriage Capscrews

53 N•m (39 lbf ft)

Integral Sideshift Carriage Lower Mounting Hooks

165 ±15 N•m (120 ±12 lbf ft)

Lift Chain Anchor Nuts

370 N•m (273 lbf ft)

Hose Sheaves to Free Lift Cylinder

66 N•m (49 lbf ft)

Hose Sheaves to Main Lift Cylinders

53 N•m (39 lbf ft)

STEERING SYSTEM

Axle Mounting Capscrews, Front and Rear

41 to 49 N•m (30 to 36 lbf ft)

Wheel Nuts for Lift Truck GLP050LX (A974)

155 to 175 N•m (114 to 129 lbf ft)

Hub Nut - Initial

200 N•m (148 lbf ft)

Hub Nut - Final

12 N•m (106 lbf ft)

King Pin Castle Nut - Initial

90 N•m (66 lbf ft)

King Pin Castle Nut - Final

34 N•m (25 lbf ft)

Steering Cylinder Mounting Capscrews

225 N•m (166 lbf ft)

DRIVE AXLE

Axle Shaft Capscrews

52 to 62 N•m (38 to 46 lbf ft)

Brake Manifold to Drive Axle Center Section Housing Capscrews

19 to 21 N•m (168 to 186 lbf in)

Differential Cover Capscrews

52 to 57 N•m (38 to 42 lbf ft)

Oil Drain Plug

50 to 55 N•m (37 to 41 lbf ft)

Input Shaft Capscrews

30 to 37 N•m (22 to 27 lbf ft)

Drop Box Housing Capscrews

19 to 23 N•m (168 to 204 lbf ft)

Hanger Assembly to Drive Axle Center Section Housing

90 to 99 N•m (66 to 73 lbf ft)

Drive Axle Mounting Capscrews to Frame

245 to 270 N•m (181 to 199 lbf ft)

Pinion Cover Capscrews

19 to 23 N•m (168 to 204 lbf in)

Hypoid Gear Capscrews

152 to 167 N•m (112 to 123 lbf ft)

Transmission Mount Bolt to Center Section Housing

225 to 250 N•m (166 to 184 lbf ft)

Wheel Nuts

155 to 175 N•m (114 to 129 lbf ft)

Retainer Ring Capscrews

11 to 12 N•m (97 to 106 lbf in)

TRANSMISSION**Hydraulic Gear Pump to Transmission Flange Head Capscrews**

38 N•m (28 lbf ft)

Flywheel to Torque Converter Housing Bolts

55 N•m (41 lbf ft)

Torque Converter to Transmission Housing Flange Bolts

38 N•m (28 lbf ft)

Charge Pump to Transmission Capscrews - Lift Trucks Manufactured Before July, 2013

19 N•m (168 lbf in)

Charge Pump to Transmission Capscrews - Lift Trucks Manufactured After July, 2013

First pass, torque in star pattern to

6 N•m (53 lbf in)

Second pass, torque in star pattern to

19 N•m (168 lbf in)

Torque Converter Access Cover Capscrews

19 N•m (168 lbf in)

Forward and Reverse Valves Capscrews

3 to 4 N•m (27 to 35 lbf in)

Torque Converter Housing Bottom Cover Plate

7.9 N•m (69.9 lbf in)

Solenoid Valve to Transmission Housing

3 to 4 N•m (27 to 35 lbf in)

ENGINE - MAZDA FE AND F2 LPG**Camshaft Pulley Lock Bolt**

48 to 66 N•m (35 to 49 lbf ft)

Camshaft Cap

18 to 27 N•m (13 to 20 lbf ft)

Cooling Fan

27 N•m (20 lbf ft)

Connecting Rod Cap

66 to 70 N•m (49 to 52 lbf ft)

Crankshaft Pulley

12 to 17 N•m (9 to 13 lbf ft)

Cylinder Head

81 to 88 N•m (60 to 65 lbf ft)

Engine Mount to Engine

55 N•m (41 lbf ft)

Engine Mount Capscrew

150 N•m (111 lbf ft)

Exhaust Manifold

22 to 29 N•m (16 to 21 lbf ft)

Flywheel

96 to 103 N•m (71 to 76 lbf ft)

Flywheel Housing

M10 Capscrews 38 N•m (28 lbf ft)

M14 Capscrews 114 to 136 N•m (84 to 100 lbf ft)

Front Housing

19 to 26 N•m (14 to 19 lbf ft)

Heat Gauge Unit

11.8 to 17.6 N•m (105 to 156 lbf in)

Intake Manifold

19 to 31 N•m (14 to 23 lbf ft)

Main Bearing Cap

84 to 90 N•m (62 to 66 lbf ft)

Oil Pan

8 to 12 N•m (71 to 106 lbf in)

Oil Pressure Switch

12 to 17 N•m (9 to 13 lbf ft)

Oil Pan Drain Plug

30 to 41 N•m (22 to 30 lbf ft)

Oil Pump

M8 Capscrews 19 to 26 N•m (14 to 19 lbf ft)
M10 Capscrews 38 to 53 N•m (28 to 39 lbf ft)

Oil Strainer

8 to 12 N•m (71 to 106 lbf in)

Rocker Cover

6 to 8 N•m (52 to 70 lbf in)

Rear Cover

8 to 12 N•m (70 to 106 lbf in)

Rocker Shaft Assembly

18 to 27 N•m (13 to 20 lbf ft)

Spark Plugs

15 to 23 N•m (11 to 16 lbf ft)

Starter

38 N•m (28 lbf ft)

Thermostat Housing Capscrews

19 to 26 N•m (14 to 19 lbf ft)

Timing Belt Cover Capscrews

7 to 10 N•m (62 to 89 lbf in)

Timing Belt Tension Lock Bolt

38 to 53 N•m (28 to 39 lbf ft)

Timing Pulley Lock Bolt

157 to 167 N•m (116 to 123 lbf ft)

Water Pump

19 to 26 N•m (14 to 19 lbf in)



Thanks for your reading.

Please click here to download complete manual instantly.

And can also choose other manuals.

Feel free --->write to me with any questions.

Our service email:

manuals007@hotmail.com