

YANMAR
SERVICE MANUAL

EXCAVATOR

MODEL *ViG*_{7E}

FOREWORD

This service manual outlines procedures for servicing YANMAR construction machinery. It contains specifications, servicing instructions and handling cautions. To obtain the maximum life and performance from YANMAR construction machinery, read this manual carefully and follow its instructions.

Please note that all dimensions and numerical values in this manual are for service reference, and are not inspection standards. Descriptions and specifications in this manual are subject to change without notice due to design improvements, etc.

CONTENTS

CHAPTER 1

GENERAL CAUTIONS FOR MAINTENANCE WORK

1-1 Correct Work	1-1
1-2 Safety Precautions	1-1
1-3 Preparations	1-1
1-4 Cautions for Disassembly and Reassembly	1-1
1-5 Cautions for Removal and Installation of Hydraulic Equipment	1-2
1-6 Cautions for Removal and Installation of Hydraulic Piping	1-2
1-7 Cautions for Handling Seals	1-3
1-8 Correct Installation of Hydraulic Hose	1-3
1-9 Specifications of Hydraulic Hose	1-6
1-10 Air Release of Hydraulic Equipment	1-11

CHAPTER 2

TECHNICAL DATA

2-1 Specifications	2-1-1
2-2 Outline Drawing and Working Area	2-2-1
2-2-1 Cabin Type (Standard Arm Type)	2-2-1
2-2-2 Cabin Type (Long Arm Type)	2-2-2
2-3 Weight List of Main Parts	2-3-1
2-4 Lifting Capacity List	2-4-1
2-4-1 Standard Arm Type	2-4-1
2-4-2 Long Arm Type	2-4-3

CHAPTER 3

SERVICE STANDARDS

3-1 Machine Performance	3-1-1
3-2 Engine	3-2-1
3-3 Undercarriage	3-3-1
3-3-1 Rubber Crawler Specifications	3-3-1
3-3-2 Steel Crawler Specifications	3-3-2
3-3-3 Common Specifications of Steel & Rubber Crawlers	3-3-3
3-4 Controls	3-4-1
3-5 Hydraulic Equipment	3-5-1
3-5-1 Hydraulic Cylinders	3-5-1
3-6 Implement	3-6-1
3-6-1 Front Attachments	3-6-1
3-6-2 Blade Moving Device	3-6-2
3-6-3 Bucket Teeth	3-6-2
3-7 List of Tightening Torque	3-7-1
3-7-1 Machine	3-7-1
3-7-2 Engine	3-7-4
3-7-3 Tightening Torque for General Bolts and Nuts	3-7-4

CHAPTER 4 ENGINE

4-1 General	4-1-1
4-1-1 How to Read This Manual	4-1-1
4-1-2 Precautions for Service Work	4-1-3
4-2 Troubleshooting	4-2-1
4-2-1 Quick Reference Table for Troubleshooting	4-2-1
4-2-2 Troubleshooting by Measuring Compression Pressure	4-2-4
4-3 Inspection and Adjustment	4-3-1
4-3-1 Oil Inspection	4-3-1
4-3-2 Cooling Water Inspection	4-3-1
4-3-3 Inspecting Water Leak from Cooling Water System and Radiator	4-3-1
4-3-4 Fan Belt Tension Inspection and Adjustment	4-3-2
4-3-5 Adjusting the Valve Clearance	4-3-3
4-3-6 Inspecting the Fuel Injection Valve Injection Pressure and Spray Pattern	4-3-3
4-3-7 Fuel Injection Timing Inspection and Adjustment	4-3-7
4-3-8 Sensor Inspection	4-3-8
4-3-9 Battery Inspection	4-3-9
4-3-10 Adjusting Operation	4-3-11
4-3-11 Long Storage	4-3-12
4-3-12 Periodic Maintenance Schedule	4-3-13
4-4 Engine Body	4-4-1
4-4-1 Introduction	4-4-1
4-4-2 Cylinder Head	4-4-2
4-4-3 Gear Train and Camshaft	4-4-10
4-4-4 Cylinder Block	4-4-15
4-5 Lubrication System	4-5-1
4-5-1 Lubrication System Diagram	4-5-1
4-5-2 Trochoid Pump Components	4-5-1
4-5-3 Disassembly (Reverse the Procedure Below for Assembly)	4-5-2
4-5-4 Servicing Points	4-5-2
4-5-5 Parts Inspection and Measurement	4-5-2
4-6 Cooling System	4-6-1
4-6-1 Cooling Water System	4-6-1
4-6-2 Cooling Water Pump Components	4-6-1
4-6-3 Disassembly (Reverse the Procedure Below for Assembly)	4-6-2
4-6-4 Servicing Points	4-6-2
4-7 Fuel Injection Pump / Governor	4-7-1
4-7-1 Introduction	4-7-1
4-7-2 Fuel Injection Pump	4-7-1
4-7-3 Fuel Injection Valve	4-7-7
4-7-4 Fuel Feed Pump	4-7-7
4-7-5 Governor	4-7-8
4-7-6 Special Service Tools for Disassembly / Assembly	4-7-9
4-8 Starting motor	4-8-1
4-8-1 Specifications	4-8-1

4-8-2 Configuration Drawing	4-8-2
4-8-3 Troubleshooting.....	4-8-3
4-8-4 Component Names and Disassembly Procedure	4-8-4
4-8-5 Disassembly Procedure	4-8-5
4-8-6 Inspection and Maintenance	4-8-7
4-8-7 Assembly.....	4-8-11
4-8-8 Adjustment	4-8-12
4-8-9 Service Standards	4-8-13
4-9 Alternator.....	4-9-1
4-9-1 Specifications	4-9-1
4-9-2 Section View.....	4-9-2
4-9-3 Troubleshooting.....	4-9-3
4-9-4 Parts Names and Disassembly Procedure.....	4-9-4
4-9-5 Inspection and Overhaul	4-9-7
4-9-6 Assembly.....	4-9-11
4-9-7 Service Standards	4-9-12
4-9-8 Performance Test.....	4-9-13
4-10 Special Service Tools.....	4-10-1
4-10-1 Special Tools.....	4-10-1
4-10-2 Measuring Instruments.....	4-10-3
4-11 Service Standards.....	4-11-1
4-11-1 Engine Turning	4-11-1
4-11-2 Engine Body.....	4-11-2
4-11-3 Lubricating Oil System (Trochoid Pump).....	4-11-6
4-11-4 Tightening Torques for Main Parts	4-11-7

CHAPTER 5

HYDRAULIC SYSTEM

5-1 Outline.....	5-1-1
5-1-1 Control Valve Operation	5-1-4
5-1-2 Additional Operation of Control Valve	5-1-6
5-2 Hydraulic Circuit Schematic	5-2-1
5-2-1 For Standard Type Machines	5-2-1
5-3 Circuit Operation	5-3-1
5-3-1 Boom	5-3-1
5-3-2 Arm.....	5-3-3
5-3-3 Bucket	5-3-5
5-3-4 Swing.....	5-3-7
5-3-5 Boom Swing	5-3-9
5-3-6 Blade	5-3-11
5-3-7 Travel	5-3-13
5-3-8 Non-deviation Travel (with Boom, Arm, Bucket or Boom Swing Operation)	5-3-15
5-3-9 Simultaneous Operation of Boom Up and Arm Retract.....	5-3-17
5-3-10 Simultaneous Operation of Boom Up and Bucket.....	5-3-19
5-3-11 Simultaneous Operation of Boom Up and Swing	5-3-21
5-3-12 Simultaneous Operation of Arm and Bucket	5-3-23

5-3-13 Hydraulic P.T.O.	5-3-25
5-3-14 Travel Alarm	5-3-27
5-3-15 4th P.T.O.	5-3-29
5-4 Pressure Adjustment	5-4-1
5-4-1 Relief Valves	5-4-1
5-4-2 Swing Brake Valve	5-4-3
5-4-3 Cut-off Valve.....	5-4-4

CHAPTER 6 HYDRAULIC EQUIPMENT

6-1 Hydraulic Pump.....	6-1-1
6-2 Control Valve.....	6-2-1
6-3 Pilot Valve	6-3-1
6-4 Swing Motor	6-4-1
6-5 Travel Motor	6-5-1

CHAPTER 7 ADJUSTMENT AND REPAIR

7-1 Electric Equipment of the Machine.....	7-1-1
7-1-1 Parts Layout of Electrical Equipment	7-1-1
7-1-2 Monitor and Alarm Systems	7-1-4
7-1-3 Wiring Diagram.....	7-1-7
7-1-4 Stop Motor Operation	7-1-9
7-1-5 Removal and Reinstallation of Engine	7-1-12
7-1-6 Removal and Reinstallation of Starter Motor.....	7-1-22
7-1-7 Removal and Reinstallation of Radiator	7-1-23
7-1-8 Removal and Reinstallation of Fan Belt and Air Compressor Driving Belt.....	7-1-26
7-1-9 Removal and Reinstallation of Fuel Injection Pump.....	7-1-27
7-2 Undercarriage	7-2-1
7-2-1 Outline	7-2-1
7-2-2 Compatibility of Main Parts.....	7-2-1
7-2-3 Points of Reassembly (Rubber Crawler Type)	7-2-2
7-2-4 Points of Reassembly (Steel Crawler Type).....	7-2-3
7-2-5 Removal and Reinstallation of Crawler	7-2-4
7-2-6 Disassembly and Reassembly of Steel Crawler.....	7-2-7
7-2-7 Disassembly and Reassembly of Front Idler	7-2-9
7-2-8 Disassembly and Reassembly of Track Roller.....	7-2-11
7-2-9 Installation of Floating Seal	7-2-13
7-2-10 Drawings of Jigs	7-2-14
7-2-11 Disassembly and Reassembly of Carrier Roller.....	7-2-16
7-3 Controls.....	7-3-1
7-3-1 Control Train.....	7-3-1
7-3-2 Mechanical Control Linkage	7-3-2
7-3-3 Adjustment of Travel Levers.....	7-3-4
7-3-4 Adjustment of Boom Swing Pedal.....	7-3-5
7-3-5 Adjustment of Blade Lever	7-3-5
7-3-6 Adjustment of Lock Lever.....	7-3-6

7-3-7 Adjustment Procedure of P.T.O. Pedal	7-3-7
7-3-8 Adjustment Procedure of P.T.O. Pedal Lock.....	7-3-7
7-3-9 Adjustment of Accelerator Lever	7-3-8
7-4 Swing Bearing	7-4-1
7-4-1 Removal and Reinstallation of Swing Bearing	7-4-1
7-5 Hydraulic Equipment	7-5-1
7-5-1 Removal and Reinstallation of Hydraulic Pump	7-5-1
7-5-2 Removal and Reinstallation of Control Valve	7-5-5
7-5-3 Removal and Reinstallation of Swing Motor.....	7-5-8
7-5-4 Removal and Reinstallation of Swivel Joint.....	7-5-10
7-5-5 Disassembly and Reassembly of Swivel Joint	7-5-13
7-5-6 Disassembly and Reassembly of Hydraulic Cylinders	7-5-16
7-5-7 Hydraulic Oil Tank.....	7-5-20
7-5-8 Piping Layout.....	7-5-26
7-6 Implement	7-6-1
7-6-1 Removal and Reinstallation of Implement.....	7-6-1
7-7 Cabin.....	7-7-1
7-7-1 Cabin.....	7-7-1

CHAPTER 8

PERIODIC INSPECTION AND SERVICING

8-1 List of Periodic Inspection and Servicing.....	8-1
--	-----

CHAPTER 9

FUEL, LUBE OIL AND GREASE RECOMMENDED

9. Fuel, Lube Oil and Grease Recommended	9-1
--	-----

CHAPTER 10

TROUBLESHOOTING

10-1 Non-breakdowns	10-1-1
10-1-1 Natural Release of Bucket.....	10-1-1
10-1-2 Discontinuous Arm Movement	10-1-1
10-1-3 Thermal Shock of Travel Motor	10-1-2
10-1-4 Elongation of Boom Swing Cylinder on 68 degrees Swing	10-1-3
10-1-5 Time Lag on Travel Speed Switching.....	10-1-4
10-1-6 Fluctuation in Oil Level of Hydraulic Oil Tank due to Temperature Change	10-1-5
10-2 Troubleshooting	10-2-1
10-2-1 Machine and Engine.....	10-2-1
10-2-2 Electrical Equipment on Panel	10-2-22

CHAPTER 11

REFERENCE DATA

11-1 Specifications for Attachment.....	11-1
---	------

GENERAL CAUTIONS FOR MAINTENANCE WORK

- 1-1 Correct Work.....1-1
- 1-2 Safety Precautions.....1-1
- 1-3 Preparations1-1
- 1-4 Cautions for Disassembly and Reassembly1-1
- 1-5 Cautions for Removal and Installation of Hydraulic Equipment1-2
- 1-6 Cautions for Removal and Installation of Hydraulic Piping1-2
- 1-7 Cautions for Handling Seals1-3
- 1-8 Correct Installation of Hydraulic Hose1-3
- 1-9 Specifications of Hydraulic Hose1-6
- 1-10 Air Release of Hydraulic Equipment1-11

1. GENERAL CAUTIONS FOR MAINTENANCE WORK

1. General Cautions for Maintenance Work

1-1 Correct Work

Correct work means the quickest possible completion of according to the correct procedures and the specified standards.

It is important when conducting certain operations always to bear in mind the equipment, tools, gauges, materials, oil and grease, etc. that you must have ready, as well as items to be checked, adjusted, or disassembled, and cautions to watch out for.

1-2 Safety Precautions

- (1) Never attempt servicing while engine is running or immediately after stopping operation.
- (2) Wear work cloths, safety shoes and helmet.
- (3) Check the equipment and tools before use. Especially, be sure to check the crane, lifting equipment and tools.
- (4) When working together with other persons, allocate everyone's share of job, arrange the signals and act in concert with the other persons.
- (5) The operation of the crane and slinging work must be performed by qualified persons.
- (6) Do not enter or pass under the raised load.
- (7) Lift and support the massive parts by crane before removing the installation bolts.
- (8) Disconnect cables from battery before repairing the electric system.
- (9) Remove the battery when welding the machine.

1-3 Preparations

- (1) Check the service record of the machine. (That is, check how many months or hours the machine has been used since the preceding overhaul, what was the trouble then and what parts were replaced.)
- (2) Have all servicing tools ready, i.e., tools, measuring devices (which have received periodic maintenance), containers, oil & grease, etc.
- (3) Have the service literature (operation manual, parts catalog, etc.) ready.

1-4 Cautions for Disassembly and Reassembly

- (1) Clean the machine before disassembly.
- (2) Check and record the condition of the machine before disassembly :
 - Model, machine number, operation hours
 - Reasons for repair, history of repair
 - Contamination of filters
 - Fuel and oil condition
 - Damage to parts, etc.
- (3) Place alignment marks on the necessary parts to facilitate reassembly.
- (4) Clean all the removed parts and new replacement parts and put them in order.
- (5) Use new seals, split pins, etc. for reassembly.

1. GENERAL CAUTIONS FOR MAINTENANCE WORK

- (6) Keep the parts apt to be damaged by water or oil apart from the oily or wet parts.
e.g.: Electrical parts, rubber parts, V-belts, etc.
- (7) Use the jig for press-fitting the bearings, bushes and oil seals. When using a hammer, use a pad block.
- (8) Clean the joint surface of all parts and keep them free from dust.
- (9) Wind the sealing tape securely, leaving a space of one or two threads from the tip of the male screw. The tape should have an overlap of about 0.4 in. (10 mm).

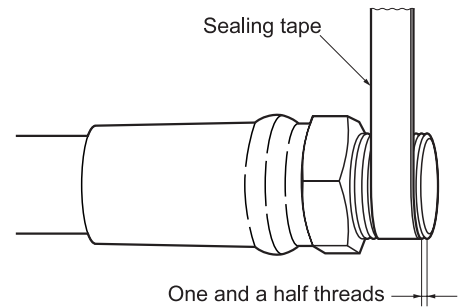

1-5 Cautions for Removal and Installation of Hydraulic Equipment

- (1) Check that the hydraulic oil temperature is low enough.
- (2) Release air from the hydraulic tank to prevent the hydraulic oil from flowing out.
- (3) Be sure to plug open the ends of hydraulic components to prevent dust from entering.
- (4) Be sure to wipe hydraulic oil from the hydraulic components so that it will not be mistaken for an oil leak.
- (5) Take care not to damage the plating on the cylinder rod.
- (6) Remove or install cylinders with rods fully retracted.
- (7) Be sure to release air after installing the hydraulic cylinders.
 - Run the engine at a low speed. Extend and retract the cylinders 4 to 5 times up to 2.0 to 3.9 in. (50 to 100 mm) from the end of the stroke. Then, fully extend and retract.
- (8) Be sure to pressurize the hydraulic tank after installing the hydraulic components (in the case of the sealed hydraulic tank). Otherwise, hydraulic pumps might suffer cavitation and their life will be shortened.
 - To pressurize the hydraulic tank, fully extend each cylinder and tighten the oil filter port plugs.

1-6 Cautions for Removal and Installation of Hydraulic Piping

- (1) Installation of hydraulic hose

Take care not to twist the hoses. (Judge whether or not the hose is twisted by the hose mark.) For hoses with a metal fitting, use two wrenches to prevent twisting.

Use one to fix the hose, and the other to tighten the fitting to the specified tightening torque. Carefully check that the hoses do not come in contact after tightening. If any contact is found, correct it or use tubes.

- (2) When installing hoses, first tighten to the specified torque and then loosen them a little. Then retighten to the specified torque.
 - Break in the installed parts before tightening (except those using seal tapes).
- (3) When installing pipes, turn the nuts more 1/4 to 1/2 turn after they reach the sharp torque rise point.
- (4) When installing or removing hoses, use two wrenches, one to fasten the hose and the other to tighten or loosen the hose to prevent twisting.
- (5) Check for oil leakage by applying max. pressure 5 to 6 times after attaching hydraulic hoses or pipes.

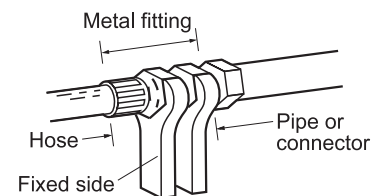

Please Click Here To Download The Complete Manual
Download Other Manuals
If Having Any Questions Feel Free To Contact us

admin@servicemanualbit.com