

# Service Manual Trucks

Group **37**  
Release **01**

Wiring diagram  
FM9, FM12, FH12, FH16, NH12 VERSION2  
FM, FH CHID A572084-  
FM, FH CHID B351630-

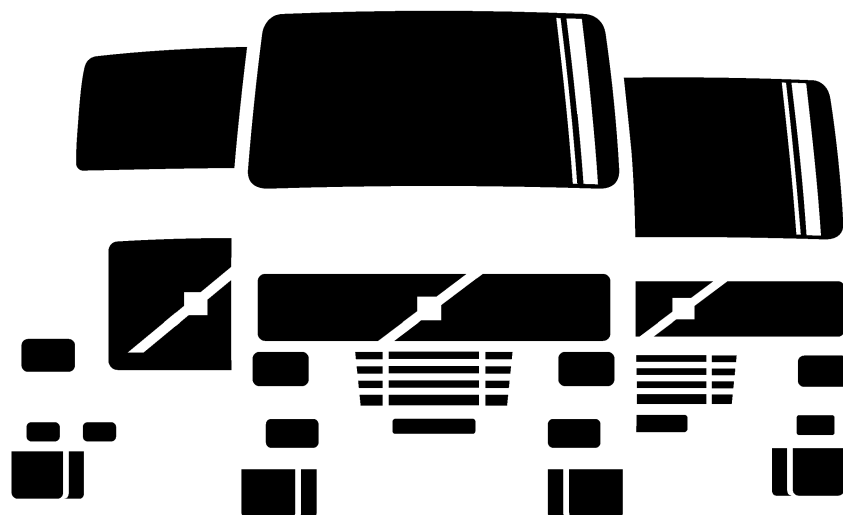

# Foreword

The descriptions and service procedures contained in this manual are based on designs and methods studies carried out up to August 03.

The products are under continuous development. Vehicles and components produced after the above date may therefore have different specifications and repair methods. When this is judged to have a significant bearing on this manual, supplementary service bulletins will be issued to cover the changes.

The new edition of this manual will update the changes.

In service procedures where the title incorporates an operation number, this is a reference to V.S.T. (Volvo Standard Times).

Service procedures which do not include an operation number in the title are for general information and no reference is made to V.S.T.

The following levels of observations, cautions and warnings are used in this Service Documentation:

**Note:** Indicates a procedure, practice, or condition that must be followed in order to have the vehicle or component function in the manner intended.

**Caution:** Indicates an unsafe practice where damage to the product could occur.

**Warning:** Indicates an unsafe practice where personal injury or severe damage to the product could occur.

**Danger:** Indicates an unsafe practice where serious personal injury or death could occur.

**Volvo Truck Corporation**  
Göteborg, Sweden

**Order number: TSP190321**

© 03 Volvo Truck Corporation, Göteborg, Sweden

All rights reserved. No part of this publication may be reproduced, stored in retrieval system, or transmitted in any forms by any means, electronic, mechanical, photocopying, recording or otherwise, without the prior written permission of Volvo Truck Corporation.

ENG13608

# Contents

<b>Example of wiring diagram</b> .....	2
<b>Component wiring diagram index</b> .....	5
<b>Component wiring diagrams</b> .....	7
<b>Illustrations index</b> .....	81
<b>Illustrations</b> .....	82
<b>Fuses</b> .....	155
<b>Relays</b> .....	157
<b>Wiring harness illustration index</b> .....	159
<b>Earth connections</b> .....	162
List of earth connections .....	164
<b>List of connectors</b> .....	165
<b>List of components</b> .....	172
<b>Abbreviations</b> .....	178
<b>Cable colour code</b> .....	179
<b>Feedback</b>	

# Example of wiring diagram

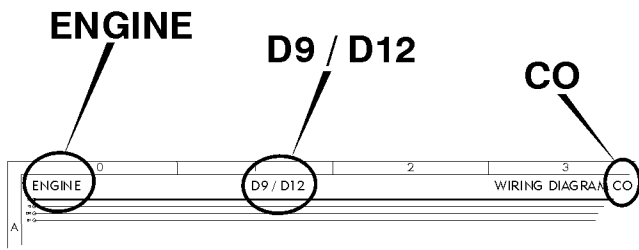

Component wiring diagram title, variant/subtitle and symbol.

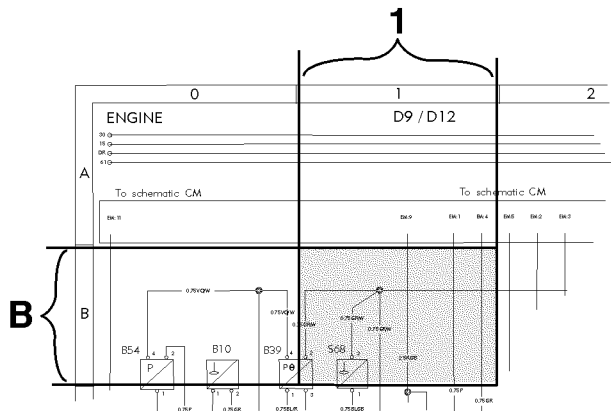

Coordinates (B 1).

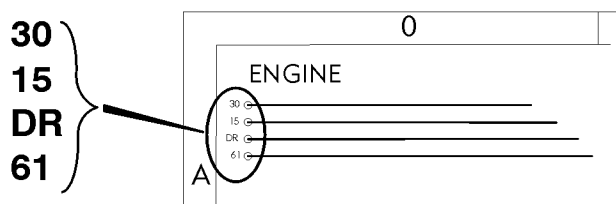

30 Voltage battery, kl.30.  
 15 Voltage with starter key in drive position, kl.15.  
 DR Voltage with starter key in drive position, preheat position and start position, kl.DR.  
 61 Voltage when alternator charges, kl.61.

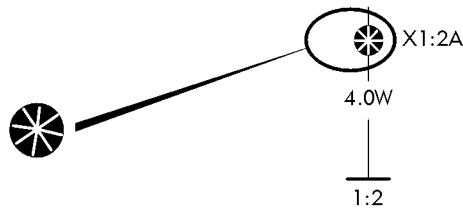

Splice.

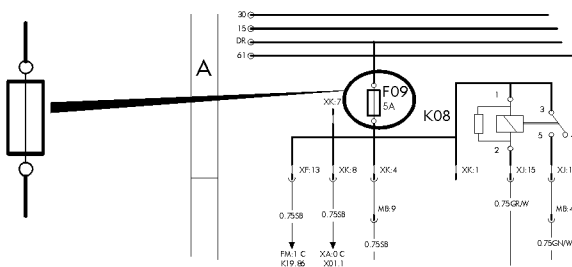

Fuse.

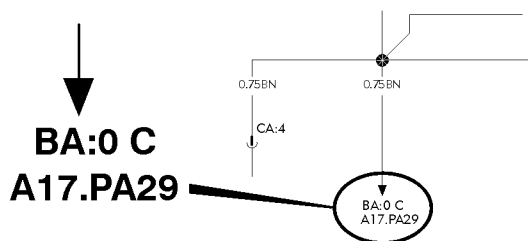

Reference arrow, for diagram BA, coordinates 0 C, component A17, connector PA pin 29.

**GEARTRONIC**  
**I-SHIFT**  
**POWERTRONIC**

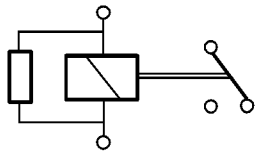
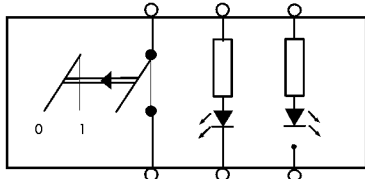
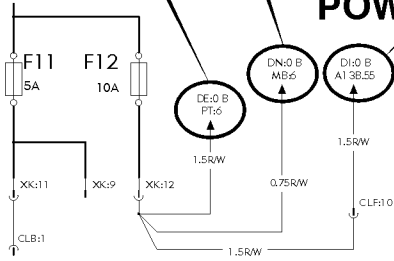

The maximum of variants are drawn, think about that all wires and components are not standard for all markets or vehicle models.

Switch.

Relay.

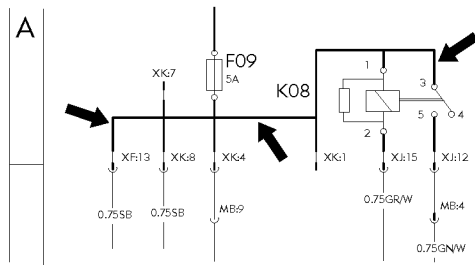

Conductor on circuit card.

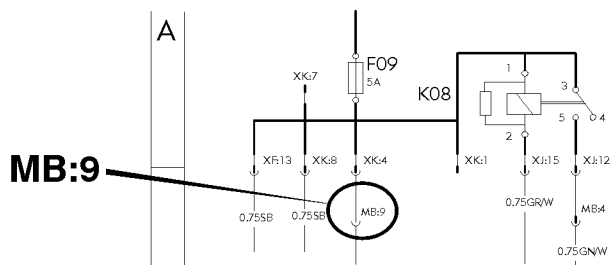

Connector MB terminal 9.

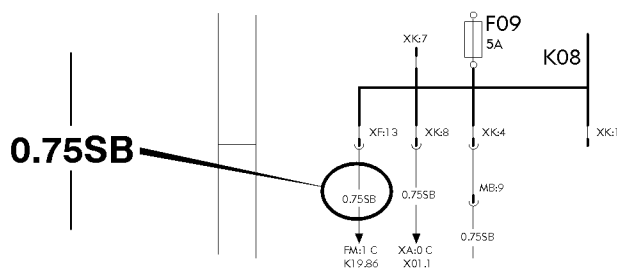

Wire area and colour.

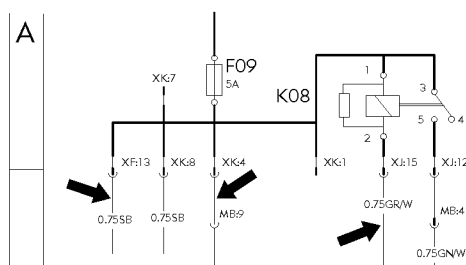

Thin lines, wires.

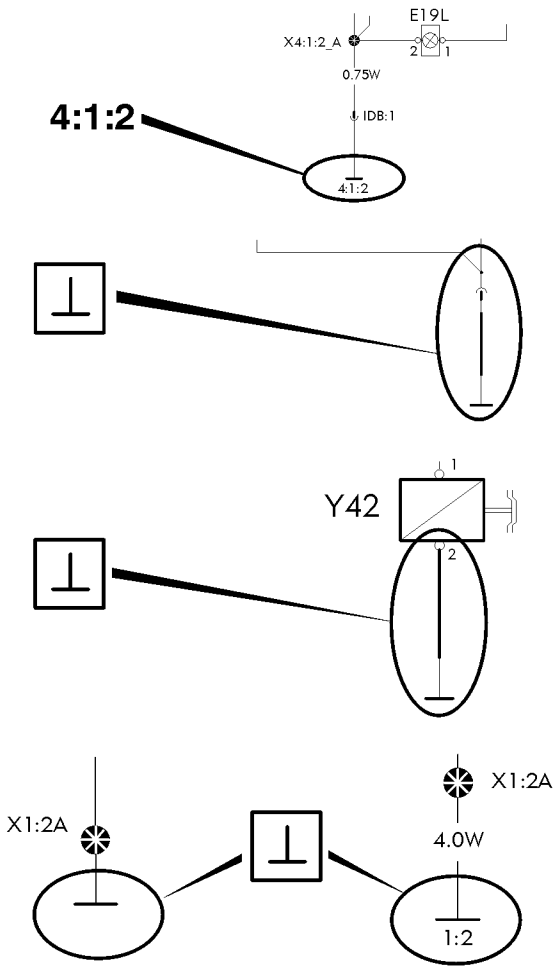

Earth connection point 4, earth connection 1 and wire 2.

Earth connection to circuit card.

Earth connection without wire.

Same splice can be drawn on several diagrams. The wire from the splice to the earth connection point will only be drawn and coded on one diagram. On the other diagrams will only the earth connection point be written besides the splice.

# Component wiring diagram index

<b>AA</b>	Power supply, starting system .....	page 7
<b>AE</b>	ADR, main switch .....	page 8
<b>BA</b>	Vehicle ECU .....	page 9
<b>BE</b>	ACC Adaptive cruise control .....	page 10
<b>BI</b>	Instrument cluster .....	page 11
<b>BM</b>	Tachograph in dash .....	page 12
<b>BN</b>	Tachograph in shelf .....	page 13
<b>BU</b>	Dynafleet .....	page 14
<b>BX</b>	FMS Gateway .....	page 15
<b>CM</b>	Engine interface .....	page 16
<b>CO</b>	Engine D9/D12 (D12 earlier design ≈ week 50 2003 ⇐) .....	page 17
	Engine D12 (later design ≈ week 51 2003 ⇒) .....	page 18
	Engine D16 .....	page 19
<b>CP</b>	ISX functions, 12V trailer ABS converter (AUS only) .....	page 20
<b>CS</b>	Engine ISX (AUS only) .....	page 21
<b>CU</b>	Fuel filter water drain .....	page 22
<b>DB</b>	Gear selector ECU .....	page 23
<b>DE</b>	Geartronic automatic gearshift .....	page 24
<b>DI</b>	Powertronic .....	page 25
<b>DM</b>	Retarder manual gearshift .....	page 26
<b>DN</b>	I-shift .....	page 27
<b>DQ</b>	Power take off .....	page 28
<b>DU</b>	Diff-lock .....	page 29
<b>EC</b>	Trailer ABS/EBS supply .....	page 30
<b>EE</b>	ABS basic, D-version .....	page 31
<b>EI</b>	ABS/ASR D-version .....	page 32
<b>EO</b>	EBS ECU .....	page 33
<b>EP</b>	EBS modulators .....	page 34
<b>EQ</b>	ESP .....	page 35
<b>FA</b>	Air-suspension .....	page 36
<b>FG</b>	Load indikator .....	page 37
<b>FK</b>	Bogie lift A-ride .....	page 38
<b>FM</b>	Axle lock, self steered axle .....	page 39
<b>FP</b>	Hydraulic steered axle .....	page 40
<b>FQ</b>	Air dryer .....	page 41
<b>FU</b>	Central lubrication system .....	page 42
<b>GA</b>	LCM head lights .....	page 43

<b>GB</b>	LCM trailer, HL-HID .....	page 44
<b>GC</b>	LCM rear lights .....	page 45
<b>GD</b>	LCM Fusebox .....	page 46
<b>GK</b>	Trailer connections (AUS only) .....	page 47
<b>GM</b>	Wiper, washer .....	page 48
<b>GQ</b>	Horn .....	page 49
<b>GU</b>	Headlights adjust .....	page 50
<b>HG</b>	Climate unit, CU,-BAS,-MCC,-ECC .....	page 51
<b>HI</b>	Air heater .....	page 52
<b>HM</b>	Water heater .....	page 53
<b>HP</b>	Short stop cabheater .....	page 54
<b>HY</b>	Climat unit, CU,-HEAT,-ACMAN,-ACAUT. ....	page 55
<b>HZ</b>	Air cooler, Brazil .....	page 56
<b>IA</b>	El. heated/adj. seat .....	page 57
<b>IE</b>	El. heat/adj. mirrors, El. window winders .....	page 58
<b>IF</b>	Foldable mirror bracket .....	page 59
<b>IH</b>	Interior light .....	page 60
<b>IM</b>	Central locking, immobiliser .....	page 61
<b>IQ</b>	El. sunroof, cig. lighter, refrigerator .....	page 62
<b>IR</b>	12V power supply .....	page 63
<b>IS</b>	SWM, SRS. Air-bag .....	page 64
<b>IU</b>	Radio .....	page 65
<b>IX</b>	Intergrated telephone .....	page 66
<b>IZ</b>	Backup camera .....	page 67
<b>KA</b>	Cab tilt .....	page 68
<b>KE</b>	Load light, 5:th wheel lamp .....	page 69
<b>KI</b>	Light sign .....	page 70
<b>KM</b>	Beacon warning light .....	page 71
<b>ME</b>	Extra fuse block, key switch relay .....	page 72
<b>NA</b>	Body builder (BB), auxsw-6 and swapbody .....	page 73
<b>NC</b>	Body builder (BB), ELCE-CK, BBM, PTO2 .....	page 74
<b>NI</b>	Extra spotlamps front/roof, max 4x70W .....	page 75
<b>NK</b>	Burglar alarm .....	page 76
<b>NR</b>	Body builder (BB), tipper tractor "HYDRKIT" .....	page 77
<b>NU</b>	Body builder (BB), DUAL-SPEED .....	page 78
<b>XA</b>	Bus J1708/J1587 .....	page 79
<b>XB</b>	Bus J1939 .....	page 80



# Component wiring diagrams

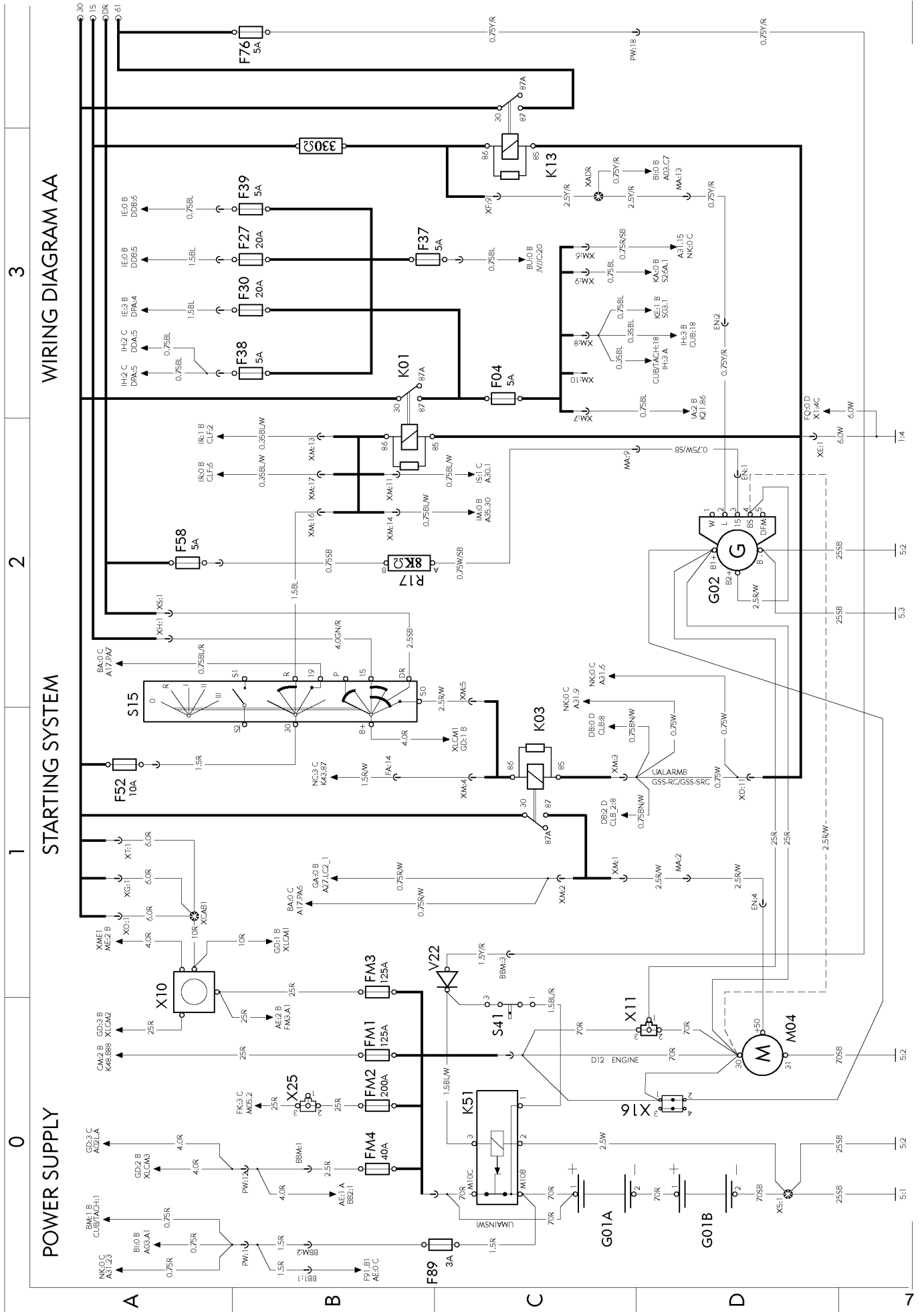



**Please Click Here To Download The Complete Manual**  
**Download Other Manuals**  
**If Having Any Questions Feel Free To Contact us**

**[admin@servicemanualbit.com](mailto:admin@servicemanualbit.com)**