

Document Title: Machine view	Function Group: 000	Information Type: Service Information	Date: 2017/7/7 0
Profile: EC55B Volvo			

Machine view

Showing Selected Profile

Valid for serial numbers			
Model	Production site	Serial number start	Serial number stop
EC55B Volvo			

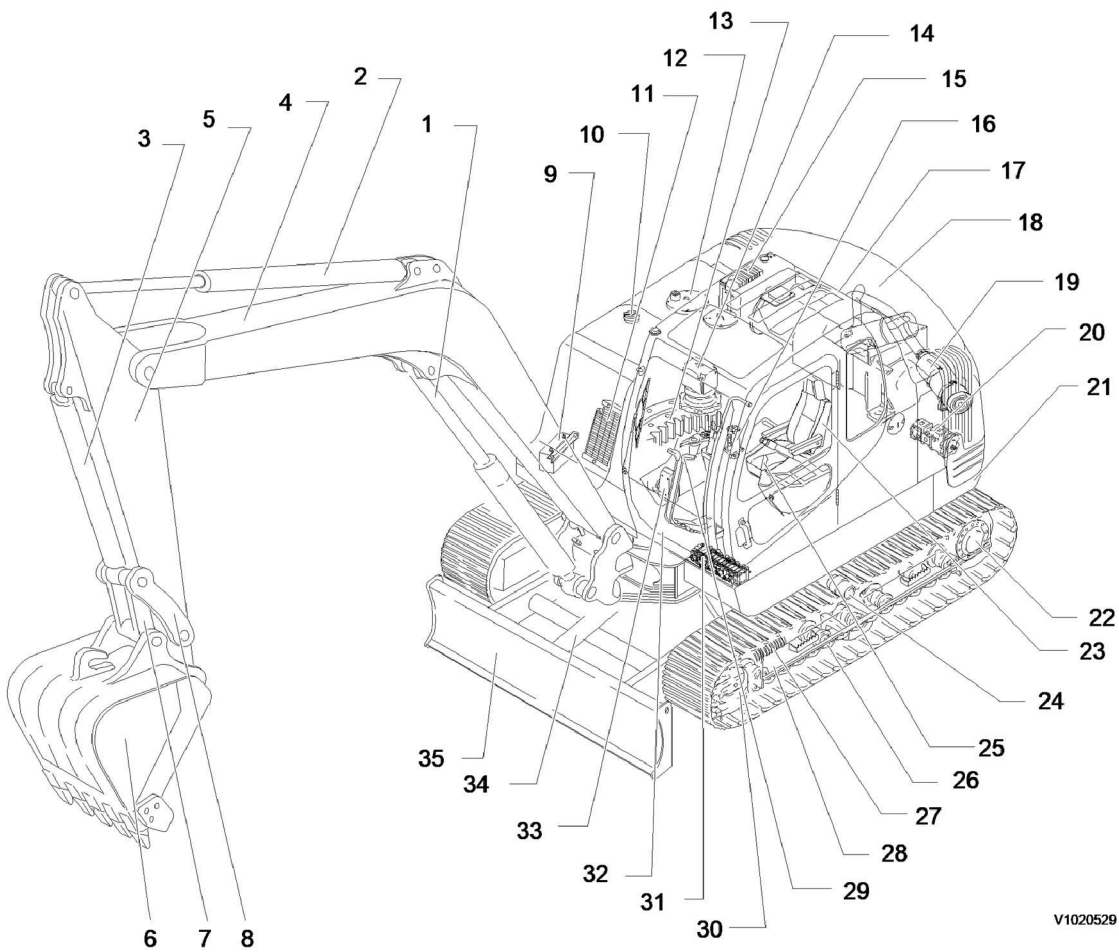

V1020529

Figure 1
Location of components

1	Boom cylinder	13	Slew ring gear	25	Control lever
2	Arm cylinder	14	Slew motor and gearbox	26	Bottom roller
3	Bucket cylinder	15	Radiator and oil cooler	27	Spring package
4	Boom	16	Center passage	28	Undercarriage
5	Arm	17	Engine	29	Travel lever
6	Bucket	18	Bonnet	30	Idler

7	Link	19	Air cleaner	31	Main control valve
8	Yoke	20	Hydraulic pump	32	Cab
9	Battery	21	Counterweight	33	Instrument panel
10	Fuel tank	22	Track motor and gearbox	34	Dozer blade cylinder
11	Air condenser	23	Operator's seat	35	Dozer blade
12	Hydraulic tank	24	Top roller		

Document Title: Measurement conversion tables	Function Group: 030	Information Type: Service Information	Date: 2017/7/7 0
Profile: EC55B Volvo			

Measurement conversion tables

Showing Selected Profile

Valid for serial numbers			
Model	Production site	Serial number start	Serial number stop
EC55B Volvo			

Length

Unit	cm	m	km	in	ft	yd	mile
cm	1	0.01	0.00001	0.3937	0.03281	0.01094	0.000006
m	100	1	0.001	39.37	3.2808	1.0936	0.00062
km	100000	1000	1	39370.7	3280.8	1093.6	0.62137
in	2.54	0.0254	0.000025	1	0.08333	0.02777	0.000015
ft	30.48	0.3048	0.000304	12	1	0.3333	0.000189
yd	91.44	0.9144	0.000914	36	3	1	0.000568
mile	160930	1609.3	1.6093	63360	5280	1760	1

1 mm = 0.1 cm, 1 mm = 0.001 m

Area

Unit	cm ²	m ²	km ²	a	ft ²	yd ²	in ²
cm ²	1	0.0001	-	0.000001	0.001076	0.000012	0.155000
m ²	10000	1	0.000001	0.01	10.764	1.1958	1550.000
km ²	-	1000000	1	10000	1076400	1195800	-
a	0.01	100	0.0001	1	1076.4	119.58	-
ft ²	-	0.092903	-	0.000929	1	0.1111	144.000
yd ²	-	0.83613	-	0.008361	9	1	1296.00
in ²	6.4516	0.000645	-	-	0.006943	0.000771	1

1 ha = 100 a, 1 mile² = 259 ha = 2.59 km²

Volume

Unit	cm ³ = cc	m ³	Liter	in ³	ft ³	yd ³
cm ³ = m liter	1	0.000001	0.001	0.061024	0.000035	0.000001
m ³	1000000	1	1000	61024	35.315	1.30796
Liter	1000	0.001	1	61.024	0.035315	0.001308
in ³	16.387	0.000016	0.01638	1	0.000578	0.000021
ft ³	28316.8	0.028317	28.317	1728	1	0.03704
yd ³	764529.8	0.76453	764.53	46656	27	1

1 gal(US) = 3785.41 cm³ = 231 in³ = 0.83267 gal(US)

Weight

Unit	g	kg	t	oz	lb
g	1	0.001	0.000001	0.03527	0.0022
kg	1000	1	0.001	35.273	2.20459
t	1000000	1000	1	35273	2204.59
oz	28.3495	0.02835	0.000028	1	0.0625
lb	453.592	0.45359	0.000454	16	1

1 tonne(metric) = 1.1023 ton(US) = 0.9842 ton(UK)

Pressure

Unit	kgf/cm ²	bar	Pa=N/m ²	kPa	lbf/in ²	lbf/ft ²
kgf/cm ²	1	0.98067	98066.5	98.0665	14.2233	2048.16
bar	1.01972	1	100000	100	14.5037	2088.6
Pa=N/m ²	0.00001	0.001	1	0.001	0.00015	0.02086
kPa	0.01020	0.01	1000	1	0.14504	20.886
lbf/in ²	0.07032	0.0689	6894.76	6.89476	1	144
lbf/ft ²	0.00047	0.00047	47.88028	0.04788	0.00694	1

1 kgf/cm² = 735.56 Torr(mmHg) = 0.96784 atm

Approximate conversions

SI	Conversion	Non-SI	Conversion	SI
Unit	Factor	Unit	Factor	Unit
Torque				
newton meter (N·m)	x 10.2	= kgf·cm	x 0.8664	= (lbf·in)
newton meter (N·m)	x 0.74	= lb·ft	x 1.36	= N·m
newton meter (N·m)	x 0.102	= kgf·m	x 7.22	= (lbf·ft)
Pressure (Pa = N/m²)				
kilopascal (kPa)	x 4.0	= in. H ₂ O	x 0.249	= kPa
kilopascal (kPa)	x 0.30	= in. Hg	x 3.38	= kPa
kilopascal (kPa)	x 0.145	= psi	x 6.89	= kPa
(bar)	x 14.5	= psi	x 0.069	= (bar)
(kgf/cm ²)	x 14.22	= psi	x 0.070	= (kgf/cm ²)
(newton/mm ²)	x 145.04	= psi	x 0.069	= (bar)
megapascal (MPa)	x 145	= psi	x 0.00689	= MPa
Power (W = J/s)				
kilowatt (kW)	x 1.36	= PS (cv)	x 0.736	= kW
kilowatt (kW)	x 1.34	= HP	x 0.746	= kW
kilowatt (kW)	x 0.948	= Btu/s	x 1.055	= kW
watt (W)	x 0.74	= ft·lb/s	x 1.36	= W

Note: () non-si unit

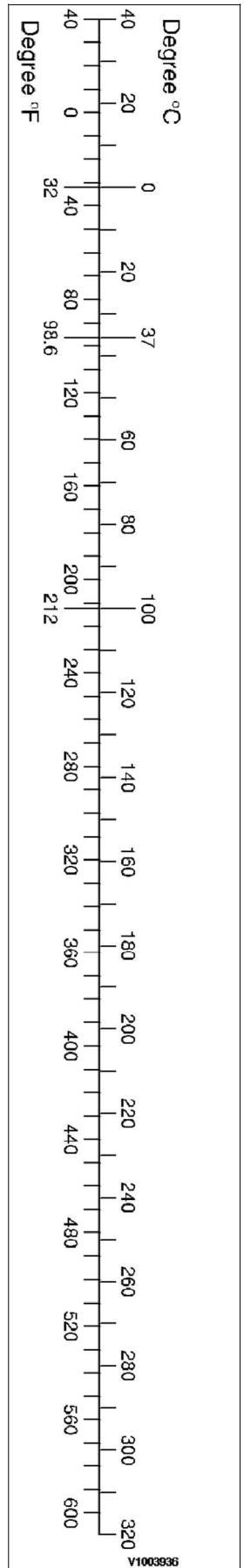

Approximate conversions

SI	Conversion	Non-SI	Conversion	SI
Unit	Factor	Unit	Factor	Unit

Energy (J = N·m)				
kilojoule (kJ)	x 0.948	= Btu	x 1.055	= kJ
joule (J)	x 0.239	= calorie	x 4.19	= J
Velocity and Acceleration				
meter per sec ² (m/s ²)	x 3.28	= ft/s ²	x 0.305	= m/s ²
meter per sec (m/s)	x 3.28	= ft/s	x 0.305	= m/s
kilometer per hour (km/h)	x 0.62	= mph	x 1.61	= km/h
Horse power/torque				
BHP x 5252 rpm = TQ (lb-ft)			TQ x rpm 5252 = B.H.P.	
Temperature				
°C = (°F - 32) /1.8		°F = (°C x 1.8) + 32		
Flow Rate				
liter/min (dm ³ /min)	x 0.264	= US gal/min x 3.785		= liter/min

Note: () non-si unit

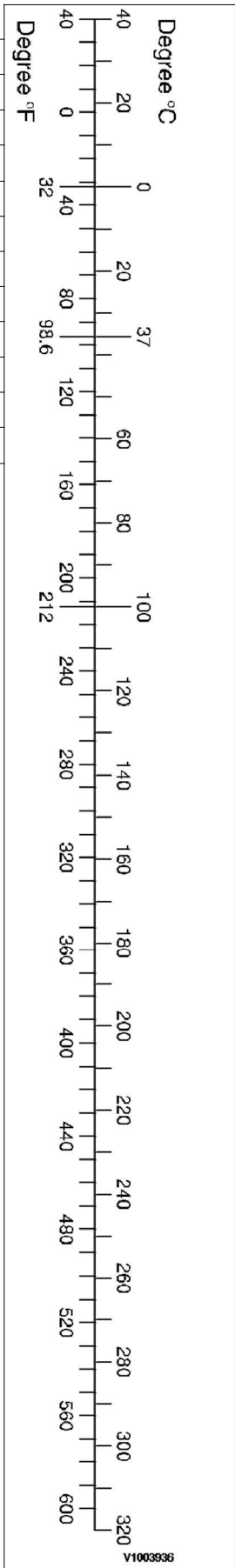

Document Title: Standard tightening torques	Function Group: 030	Information Type: Service Information	Date: 2017/7/7 0
Profile: EC55B Volvo			



Standard tightening torques

Showing Selected Profile

Valid for serial numbers			
Model	Production site	Serial number start	Serial number stop
EC55B Volvo			

The following charts give the standard tightening torques of screws and nuts. Exceptions are given in each sections of "disassembly and assembly".

Tightening torque (meter)

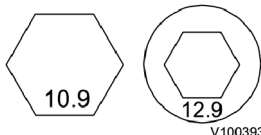
Classification		4.8T			8.8T			10.9T, 12.9T		
Screw type										
Screw size		Tightening torque			Tightening torque			Tightening torque		
mm	inch	N m	kgf m	lbf ft	N m	kgf m	lbf ft	N m	kgf m	lbf ft
M 4	0.15	1.96 ±0.19	0.2 ±0.02	1.4 ±0.1	-	-	-	3.92 ±0.39	0.4 ±0.04	2.9 ±0.3
M 5	0.19	2.94 ±0.29	0.3 ±0.03	2.2 ±0.2	5.88 ±0.59	0.6 ±0.06	4.3 ±0.4	7.84 ±0.78	0.8 ±0.08	5.8 ±0.6
M 6	0.23	4.90 ±0.49	0.5 ±0.05	3.6 ±0.4	9.8 ±0.98	1.0 ±0.10	7.2 ±0.7	13.72 ±1.37	1.4 ±0.14	10.1 ±1
M 8	0.31	11.76 ±1.17	1.2 ±0.12	8.7 ±0.9	23.541 ±2.35	2.4 ±0.24	17.3 ±1.7	32.36 ±2.94	3.3 ±0.3	23.8 ±2.2
M 10	0.39	22.55 ±2.25	2.3 ±0.23	16.6 ±1.7	48.05 ±4.9	4.9 ±0.5	35.4 ±3.6	63.74 ±6.86	6.5 ±0.7	46.9 ±5.1
M 12	0.46	39.22 ±3.92	4.0 ±0.4	29 ±3	85.32 ±8.83	8.7 ±0.9	62.8 ±6.5	110.81 ±10.78	11.3 ±1.1	81.6 ±7.9
M 14	0.55	62.7 ±5.88	6.4 ±0.6	46 ±4	140.24 ±13.73	14.3 ±1.4	103.2 ±10.1	175.53 ±17.65	17.9 ±1.8	129.2 ±13
M 16	0.62	93.16 ±8.82	9.5 ±0.9	69 ±6	219.67 ±21.57	22.4 ±2.2	161.7 ±15.9	261.83 ±26.47	26.7 ±2.7	192.8 ±19.5
M 18	0.71	132.3 ±13.72	13.5 ±1.4	97 ±10	290.28 ±29.42	29.6 ±3.0	213.7 ±21.7	372.65 ±37.26	38.0 ±3.8	274.4 ±27.4
M 20	0.78	182.40 ±18.63	18.6 ±1.9	134 ±14	430.51 ±43.14	43.9 ±4.4	317.0 ±31.8	511.90 ±50.99	52.2 ±5.2	376.9 ±37.5
M 22	0.87	242.22 ±24.51	24.7 ±2.5	178 ±18	579.57 ±57.85	59.1 ±5.9	426.7 ±42.6	680.58 ±67.66	69.4 ±6.9	501.1 ±49.8
M 24	0.94	314.79 ±31.38	32.1 ±3.2	232 ±23	740.40 ±73.54	75.5 ±7.5	545.1 ±54.2	884.56 ±88.25	90.2 ±9.0	651.2 ±65
M 30	1.17	613.80	62.6 ±6.3	452 ±45	-	-	-	1726.95	176.1	1271.4

		±61.78						±172.59	±17.6	±127.1
M 36	1.40	1061.08 ±105.91	108.2 ±10.8	781 ±78	-	-	-	2984.16 ±298.12	304.3 ±30.4	2197 ±219.5
M 42	1.65	1684.78 ±168.67	171.8 ±17.2	1240 ±124	-	-	-	4738.57 ±473.66	483.2 ±48.3	3488.7 ±348.7
M 45	1.77	2072.15 ±206.92	211.3 ±21.1	1525 ±152	-	-	-	5828.09 ±582.51	594.3 ±59.4	4290.9 ±428.9

Tightening torque (inch)

Classification		4.8T			8.8T			10.9T, 12.9T		
Screw size		Tightening torque			Tightening torque			Tightening torque		
mm	inch	N m	kgf m	lbf ft	N m	kgf m	lbf ft	N m	kgf m	lbf ft
1/4	6.35	9.80 ±0.98	0.6 ±0.06	4.3 ±0.4	23.53 ±2.35	1.0 ±0.1	7.2 ±0.7	16.67 ±1.96	1.7 ±0.2	12.2 ±1.2
5/16	7.94	11.76 ±1.17	1.2 ±0.12	8.7 ±0.8	19.61 ±1.96	2.0 ±0.2	14.4 ±1.4	29.42 ±2.94	3.0 ±0.3	21.7 ±2.2
3/8	9.53	19.61 ±1.96	2.0 ±0.20	14.4 ±1.4	40.20 ±3.92	4.1 ±0.4	29.6 ±2.9	54.91 ±4.90	5.6 ±0.5	40 ±4
7/16	11.11	31.38 ±3.13	3.2 ±0.32	23 ±2	59.82 ±5.88	6.1 ±0.6	44.0 ±4.3	87.27 ±8.82	8.9 ±0.9	64 ±6
1/2	12.70	46.09 ±4.60	4.7 ±0.47	34 ±3	100.02 ±9.80	10.2 ±1.0	73.6 ±7.2	131.40 ±12.74	13.4 ±1.3	97 ±10
9/16	14.29	66.68 ±6.66	6.8 ±0.68	50 ±5	140.23 ±13.72	14.3 ±1.4	103.2 ±10.1	186.32 ±18.63	19.0 ±1.9	137 ±14
5/8	15.88	91.20 ±9.12	9.3 ±0.93	67 ±7	200.05 ±19.61	20.4 ±2.0	147.3 ±14.4	255.95 ±25.49	26.1 ±2.6	190 ±19
3/4	19.05	156.90 ±15.69	16.0 ±1.60	115 ±15	-	-	-	442.28 ±44.12	45.1 ±4.5	325 ±33
7/8	22.22	250.07 ±25.00	25.5 ±2.55	185 ±19	-	-	-	702.15 ±70.60	71.6 ±7.2	520 ±52
1	25.40	372.65 ±37.26	38.0 ±3.80	275 ±27	-	-	-	1048.33 ±104.93	106.9 ±10.7	770 ±77
1 1/8	28.58	530.54 ±53.05	54.1 ±5.41	390 ±39	-	-	-	1492.57 ±149.06	152.2 ±15.2	1100 ±110
1 1/4	31.75	727.65 ±72.76	74.2 ±7.42	535 ±54	-	-	-	2048.61 ±204.95	208.9 ±20.9	1510 ±151
1 3/4	34.93	968.89 ±96.88	98.8 ±9.88	710 ±71	-	-	-	2724.29 ±272.62	277.8 ±27.8	2000 ±200
1 1/2	38.1	1257.21 ±125.72	128.2 ±12.82	925 ± 93	-	-	-	3537.26 ±354.02	360.7 ±36.1	2600 ±260

NOTE!

This torque table does not apply to screws with nylon packings or where nonferrous metal washers are to be used, or which require tightening to a different specified torque, or tightening procedure.

NOTE!

N m (Newton meter): 1 N m \cong 0.1 kgf m

Tightening torque of split flange screws

Use these torques for split flange screws.

Tightening torque (split flange screws)

Thread diameter of screw (mm)	Width across flats (mm)	Tightening torque		
		N m	kgf m	lbf ft

10	14	65.7 ±6.8	6.7 ±0.7	48.4 ±5
12	17	112 ±9.8	11.5 ±1	83 ±8
16	22	279 ±29	28.5 ±3	206 ±20

Tightening torque for hydraulic plugs with O-ring

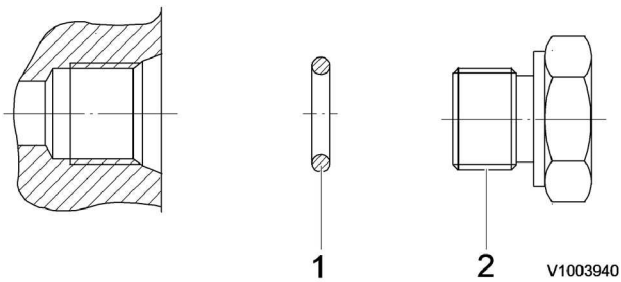

Figure 1
Hydraulic plugs with O-ring

- 1. O-ring
- 2. Plug

Pf thread

Tightening torque (hydraulic plugs)

Thread	Plug part No.	Tightening torque N m	Tightening torque kgf m	Tightening torque lbf ft
1/8	9415-11012	24.51 ±1.96	2.5 ±0.2	18 ±1.4
1/4	9415-11022	49.03 ±4.90	5.0 ±0.5	36 ±3.6
3/8	9415-11032	73.54 ±4.90	7.5 ±0.5	54 ±3.6
1/2	9415-11042	107.87 ±9.80	11.0 ±1.0	79 ±7
3/4	9415-11052	176.52 ±9.80	18.0 ±1.0	130 ±7
1	9415-11062	205.94 ±19.61	21.0 ±2.0	152 ±14

Tightening torque for swivel nut fitting with O-ring

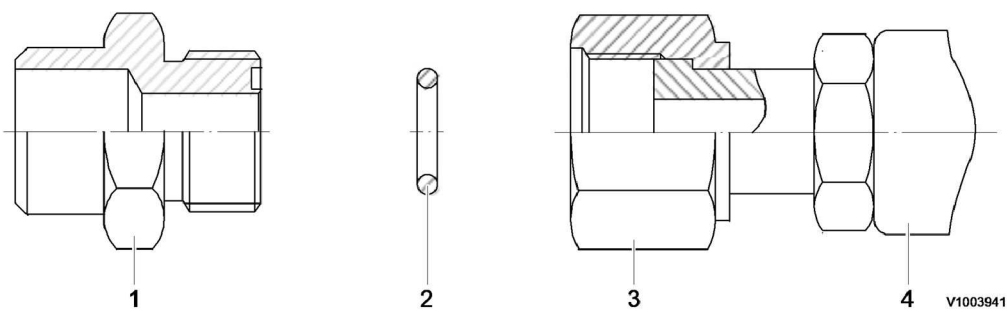

Figure 2
Swivel nut fitting with O-ring

- 1. Connector
- 2. O-ring
- 3. Swivel nut
- 4. Hose

Tightening torque for swivel nut fitting

Tube outer diameter (in)	Thread size (in)	Tightening torque, N m	Tightening torque, kgf m	Tightening torque, lbf ft
1/2	UN 13/16 – 16	93.16 ±9.31	9.5 ±0.95	69 ±7
3/4	UN 1 3/16 – 12	176.52 ±17.65	18 ±1.8	130 ±13
1	UN 1 7/16 – 12	205.94 ±20.59	21 ±2.1	152 ±15

Document Title: Engine, specifications	Function Group: 030	Information Type: Service Information	Date: 2017/7/7 0
Profile: EC55B Volvo			

Engine, specifications

Showing Selected Profile

Valid for serial numbers			
Model	Production site	Serial number start	Serial number stop
EC55B Volvo			

Specifications

Item	Unit	Specifications	
		EC55B	EW55B
Model	-	Yanmar diesel 4T NV 94L (Korea serial no.: ~ 33292) (China serial no.: ~ 50064)	Yanmar diesel 4T NV 94L (Serial no.: ~ 30335)
		Volvo D3.1 (Korea serial no.: 33	Volvo D3.1 (Serial no.: 36 ~)

29
3
~)
(Ch
ina
seri
al
no.:
50
06
5
~)

Type	-	Vertical, in-line, 4- cylinder, water- cooled diesel engine
Combustion chamber	-	Direct injection
Number of cylinder	-	4
Cylinder bore × Stroke	m m (i n c h)	94 × 110 (3.7 × 4.3)
Total displacement	c c (c u i n)	3054 (186)
Rated output	k W (H P) (P S)	37.1 (49.7) (50.5)

Maximum torque (Net)	Nm (kgm) /rpm (lbf ft/rpm)	193.19 ~ 209.86 (19.7 ~ 21.4/1400) (142 ~ 155/1400)
Firing order	-	1 - 3 - 4 - 2 (No.1 cylinder on flywheel side)
Compression ratio	-	19 : 1
Low idle (No-load)	rpm	870 ±4 (Korea serial no: ~ 34475) (China serial no: ~ 50129)
		870 ±40 (Korea serial no: ~ 930)

34
47
6
~)
(Ch
ina
seri
al
no:
50
13
0
~)

High idle (No- load)	r p m	226 0 ±4 0	242 0 ±40
Fuel consu mptio n (rated)	g / P S h (g / k W h)	168 (22 9)	170 (23 1.2)
F u e l t a n k	Ca pa cit y	Li t e r s (U S g al)	100 (26.4)
	Filt er	-	60#
Nozzl e press ure	M P a (k g f/ c m ²) (p si)	21.57 22.55 (220 230) 3128 3270) (215.74 ~ 225.55)	~ ~ ~ ~
V a l	Inl et	m m	0.15 0.25
	Ex		(0.006 ~

ve c l e a r a n c e	ha ust (i n c h)		0.010)
O il p a u n c a p a c it y	M axi m u m/ Mi ni m u m	Li t e r s (U S g al)	10.1 (2.7) / 4.5 (1.2)
C o o l a n t	Tot al (in clu de ra dia tor)	Li t e r s (U S g al)	4.2 (1.11)
Weig ht of engin e (dry)	k g (l b)	235 (518) (Korea serial no: ~ 34475) (China serial no: ~ 50129)	
		270 (595) (Korea serial no: 34476 ~) (China serial no: 50130 ~)	

Document Title: Valve system specifications	Function Group: 030	Information Type: Service Information	Date: 2017/7/7 0
Profile: EC55B Volvo			

Valve system specifications

Showing Selected Profile

Valid for serial numbers			
Model	Production site	Serial number start	Serial number stop
EC55B Volvo			

Adjustment Specifications

Valve clearance, Intake	0.15 ~ 0.25 mm (0.006 ~ 0.010 in)
Valve clearance, Exhaust	0.15 ~ 0.25 mm (0.006 ~ 0.010 in)
Valve bridge clearance	0

Cylinder head

Item	Standard	Limit
Combustion Surface Distortion (Flatness)	0.05 mm (0.0020 in) or less	0.15 mm (0.0059 in)
Valve Recession, Intake	0.36 ~ 0.56 mm (0.0142 ~ 0.0220 in)	0.8 mm (0.0315 in)
Valve Recession, Exhaust	0.35 ~ 0.55 mm (0.0138 ~ 0.0217 in)	0.8 mm (0.0315 in)
Valve seat angle, Intake	120°	—
Valve seat angle, Exhaust	90°	—
Seat correction angle	40°, 150°	—

Document Title: Lubrication specifications	Function Group: system, 030	Information Type: Service Information	Date: 2017/7/7 0
Profile: EC55B Volvo			

Lubrication system, specifications

Showing Selected Profile

Valid for serial numbers			
Model	Production site	Serial number start	Serial number stop
EC55B Volvo			

Item	Unit	Specifications
Lubrication oil pump, type	—	Trochoid pump
Engine oil pressure	Rated engine speed	MPa (psi) (bar) 0.29 ~ 0.39 (42 ~ 56.6) (2.9 ~ 3.9)
	Low idle speed	MPa (psi) (bar) ≥0,06 (8.7) (0.6)
Oil Pressure Switch Operating Pressure	MPa (psi) (bar)	0.04 ~ 0.06 (5.8 ~ 8.8) (0.4 ~ 0.6)

Document Title: Fuel system, specifications	Function Group: 030	Information Type: Service Information	Date: 2017/7/7 0
Profile: EC55B Volvo			

Fuel system, specifications

Showing Selected Profile

Valid for serial numbers			
Model	Production site	Serial number start	Serial number stop
EC55B Volvo			

Fuel system	
Fuel supply pump	Electric
Injection fuel pump	Direct injection
Fuel injector pressure	21.6 ~ 22.6 MPa (3133 ~ 3278 psi) (216 ~ 226 bar)

Document Title: Fuel filler pump, specifications	Function Group: 030	Information Type: Service Information	Date: 2017/7/7 0
Profile: EC55B Volvo			

Fuel filler pump, specifications

Showing Selected Profile

Valid for serial numbers			
Model	Production site	Serial number start	Serial number stop
EC55B Volvo			

Specifications

Item	Specifications
Rated voltage	DC 12 V
Rated current	15 A (at 3 m head)
Output flow	35 lpm (at 3 m head)
Continuous working time (minutes)	30 at 20 °C, 25 at 30 °C, 20 at 40 °C
Working temperature	-30 ~ 80 °C (-22 ~ 176 °F)

Document Title: Fuel injection pump, specifications	Function Group: 030	Information Type: Service Information	Date: 2017/7/7 0
Profile: EC55B Volvo			

Fuel injection pump, specifications

Showing Selected Profile

Valid for serial numbers			
Model	Production site	Serial number start	Serial number stop
EC55B Volvo			

Specifications

Item	Unit	Specifications
Plunger diameter	mm (in)	10 (0.39)
Max. cam lift	mm (in)	10 (0.39)
Fuel injection timing control system	-	Built-in hydraulic control timer
Fuel feed pump	-	Forced lubrication system with trochoid pump
Lubrication system	-	Engine system oil
Dry weight	kg (lb)	11.5 (25.4)

Document Title: Injectors, specification	Function Group: 030	Information Type: Service Information	Date: 2017/7/7 0
Profile: EC55B Volvo			

Injectors, specification

Showing Selected Profile

Valid for serial numbers			
Model	Production site	Serial number start	Serial number stop
EC55B Volvo			

Fuel injection nozzle, specifications

Description	Unit	Specifications							
		Nozzle opening pressure	-	21.57 MPa	+0.98 0	220 kgf/ cm ²	+10 0	3129 psi	+142 0
Nozzle angle	°	162							
		159							
No. of nozzles × diameter	mm (inch)	5 × 0.16 (0.2 × 0.0063)							
		5 × 0.17 (0.2 × 0.0067)							

Document Title: Cooling specifications	system, 030	Function Group:	Information Type: Service Information	Date: 2017/7/7 0
Profile: EC55B Volvo				

Cooling system, specifications

Showing Selected Profile

Valid for serial numbers			
Model	Production site	Serial number start	Serial number stop
EC55B Volvo			

Specifications

Item		Unit	Specifications
Radiator	Core type	–	C.F (wave)
	Machine serial number: ~ 34500 Core size (W × H × D)	mm (inch)	526 × 550 × 49 (3 row) (20.7 × 21.7 × 1.9)
	Machine serial number: 34501 ~) Core size (W × H × D)	mm (inch)	526 × 550 × 49 (3ROW) (20.7 × 21.7 × 1.9) (Korea serial no.: ~ 34475) (China serial no.: ~ 50129)
			526 × 550 × 66 (3ROW) (20.7 × 21.7 × 2.6) (Korea serial no.: 34476 ~) (China serial no.: 50130 ~)
	Overall heat radiating area	m ² (yd ²)	15.1 (18.1)
	Coolant capacity	Liters (US gal)	5.0 (1.3)
Hydraulic oil cooler	Core type	–	C.F (wave)
	Core size (W × H × D)	mm (inch)	517.6 × 481 × 32 (row) (20.4 × 18.9 × 1.3)
	Overall heat radiating area	m ² (yd ²)	8.3 (10)

Document Title: Battery, specifications	Function Group: 030	Information Type: Service Information	Date: 2017/7/7 0
Profile: EC55B Volvo			

Battery, specifications

Showing Selected Profile

Valid for serial numbers			
Model	Production site	Serial number start	Serial number stop
EC55B Volvo			

Specifications

Item		Unit	Specifications
Battery	Type	–	MF
	Capacity	V-Ah	12–100
	Quantity	EA	1

Document Title: Alternator, specifications	Function Group: 030	Information Type: Service Information	Date: 2017/7/7 0
Profile: EC55B Volvo			

Alternator, specifications

Showing Selected Profile

Valid for serial numbers			
Model	Production site	Serial number start	Serial number stop
EC55B Volvo			

Specifications

Item	Specifications
Battery voltage	12 V
Nominal out (13.5 V heat)	55 A
Operating revolution	1,070 - 18,000 per minute
Grounding characteristics	Negative grounding
Direction of revolution (viewed from pulley)	Clockwise
Operating temperature	-30 ~ 90 °C(-22 ~194 °F)
Integrated regulator	IC regulator
Pulley (outside diameter)	69.2 mm
Belt shape	Type A
Belt tension	270 ~ 444 N·m (60 ~ 100 lbf·ft)

Document Title: Starter specifications	Function Group: motor, 030	Information Type: Service Information	Date: 2017/7/7 0
Profile: EC55B Volvo			

Starter motor, specifications

Showing Selected Profile









Valid for serial numbers			
Model	Production site	Serial number start	Serial number stop
EC55B Volvo			

Specifications

Item	Unit	Specifications
Nominal output	kW	2.3
Weight	kg (lb)	5.5 (12.1)
Revolution direction (as viewed from pinion)	–	Clockwise
Engagement system	–	Magnetic shift
No load	Terminal voltage/current	V/A
	Revolution	rpm
Load	Terminal voltage/current	V/A
	Torque	kgf·m (lbf·ft)
Clutch system	–	Over-running
Pinion projection voltage (at 100 °C)	V	8.6 or less

Please Click Here To Download The Complete Manual
Download Other Manuals
If Having Any Questions Feel Free To Contact us

admin@servicemanualbit.com

-
-  [General](#)
 -  [Standard Parts , Service](#)
 -  [Engine with Mounting and Equipment](#)
 -  [Elec. System, Warning System, Information System, Instruments](#)
 -  [Power Transmission](#)
 -  [Frame and Track Unit](#)
 -  [Machinery House, Cab, Exterior Trim Parts Anywhere](#)
 -  [Hydraulic System, Digging, Handling, Grading Equipment, Misc Equipment](#)