

Document Title: Description, general	Function Group: 000	Information Type: Service Information	Date: 2018/4/14
Profile: EC15D Volvo			

Description, general

Showing All Profiles

Valid for serial numbers			
Model	Production site	Serial number start	Serial number stop
EC15D Volvo			
EC18D Volvo			
EC20D Volvo			

The **EC15D, EC18D, EC20D** are compact excavators with track chain drive.

The engine is a vertical, water-cooled, in-line, three cylinder, four-stroke diesel engine, type D0.9A. with indirect fuel injection system. The engine complies with the legal requirements to emissions standard Tier 4 final.

The drive movement is provided by two tracks, each of which is driven by an axial piston motor. The track motor of the **EC15D** has one travel step, and the drive motor of the **EC18D, EC20D** has two travel steps.

The hydraulic system is a hydraulic load-sensing system which guarantees complete independence of the individual movements.

The superstructure swivel movement is guaranteed by a hydraulic axial piston engine which directly (i.e. without reduction gear) drives a ball-mounted swing ring gear with internal toothing and remote lubrication.

The undercarriage of the **EC15D** consists of a welded H-shaped centre section. The swing ring gear has remote lubrication. The track unit consisting of a track chain, guide wheel including spring package, drive wheel, slide rails, lower running rollers and dozer blade is also part of the undercarriage.

The undercarriage of the **EC18D** and **EC20D** consists of a welded H-shaped centre section. To increase the stability, the suspension is hydraulically width-adjustable. The dozer blade has blade extensions with fixing brackets in order to allow optimum ploughing results even with the chassis extended. The swing ring gear has remote lubrication. The guide wheel including spring package, drive wheel, slide rails, lower running rollers and dozer blade is also part of the undercarriage.

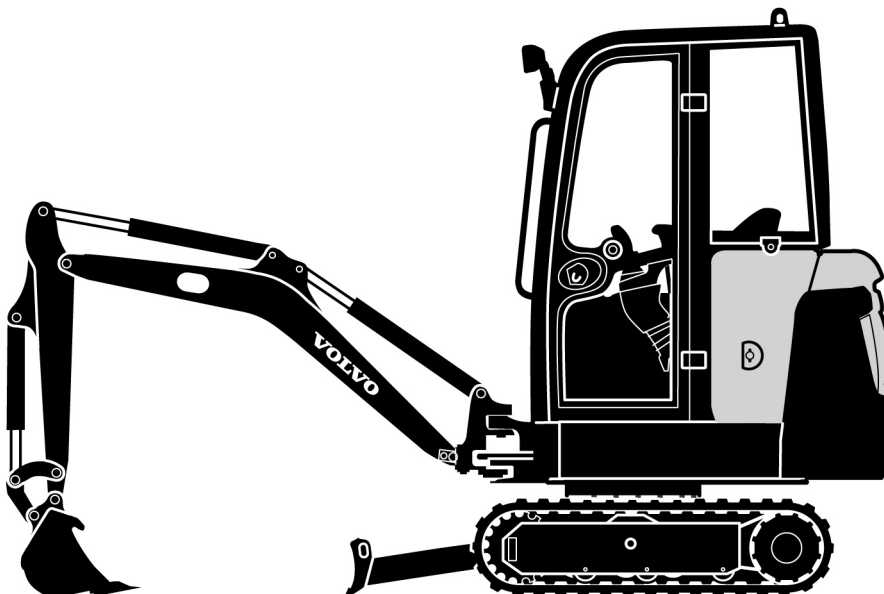
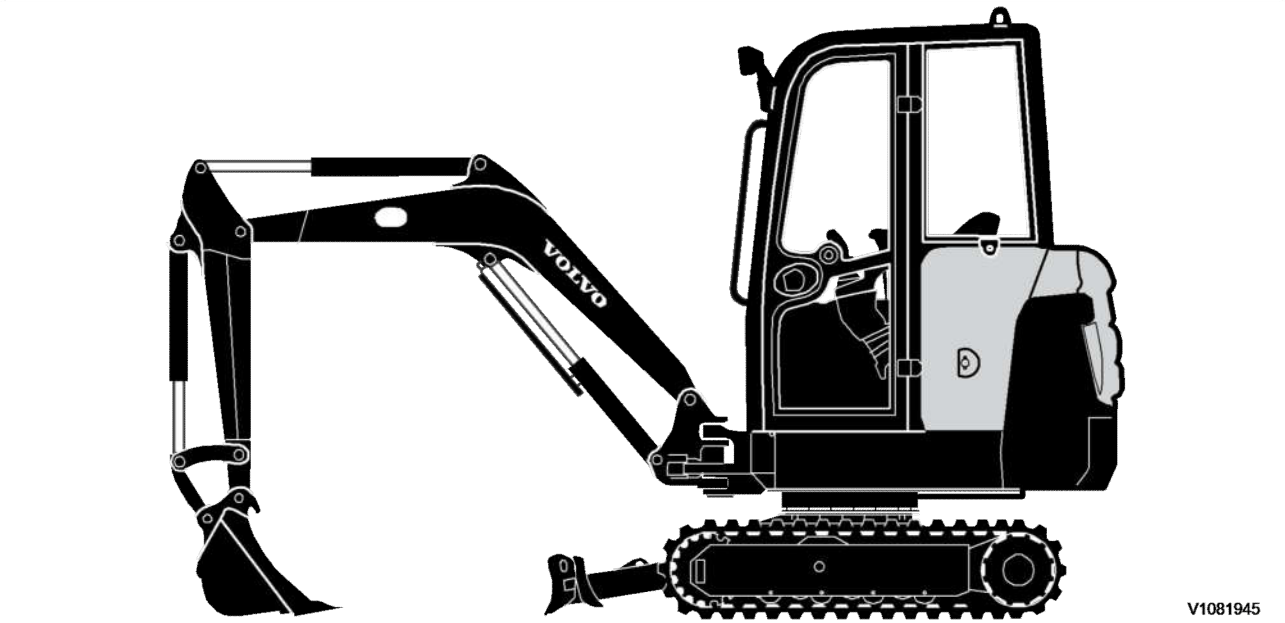

Figure 1
Compact excavator EC15D, EC18D



V1081945

Figure 2
Compact Excavator EC20D

Document Title: Product plate, description	Function Group: 000	Information Type: Service Information	Date: 2018/4/14
Profile: EC15D Volvo			

Product plate, description

Showing All Profiles

Valid for serial numbers			
Model	Production site	Serial number start	Serial number stop
EC15D Volvo			
EC18D Volvo			
EC20D Volvo			

The following illustrations and descriptions show the product plates on the excavator.

When ordering spare parts and for telephone enquiries and in correspondence, always quote the model designation and product identification number.

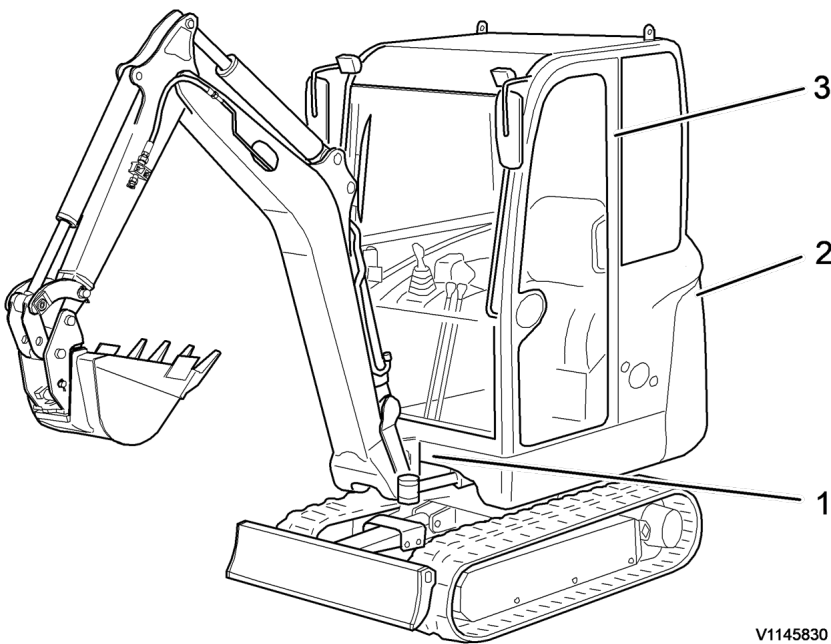

V1145830

Figure 1

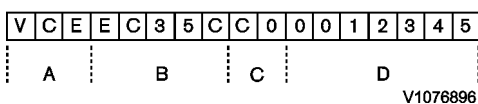

Figure 2
Example of 17 digit PIN number on PIN plate

- A. World Manufacturing Code
- B. Machine description
- C. Check letters
- D. Serial number

1 Product Identification plate (PIN) and supplementary PIN plate (EU countries only)

The product plate contains name and address of the manufacturer, model/type designation and 17 digit PIN number.

The supplementary plate contains information about machine mass in kg, engine net power in Kw, manufacturing year, machine serial number and a CE-mark.

Machine mass

The machine mass in kg on the supplementary PIN plate is based on the most standard definition of the machine in accordance with ISO 6016. For safety reasons, 103% of the machine mass will be shown on the supplementary PIN plate.

2 Engine identification plate

The engine identification plate contains information about manufacturer, designation and engine serial number. It is located on the engine head cover.

3 TOPS/ROPS and OPG plate

The plate is located inside the cab on the left B-pillar. TOPS (Tip-Over-Protection-Structure) and ROPS (Roll-Over-Protection-Structure) provide protection in case the machine should turn over. OPG (Operator Protective Structure) provides protection against falling down objects.

Document Title: Component locations	Function Group: 000	Information Type: Service Information	Date: 2018/4/14
Profile: EC15D Volvo			

Component locations

Showing All Profiles

Valid for serial numbers			
Model	Production site	Serial number start	Serial number stop
EC15C Volvo			
EC15D Volvo			
EC17C Volvo			
EC18C Volvo			
EC18D Volvo			

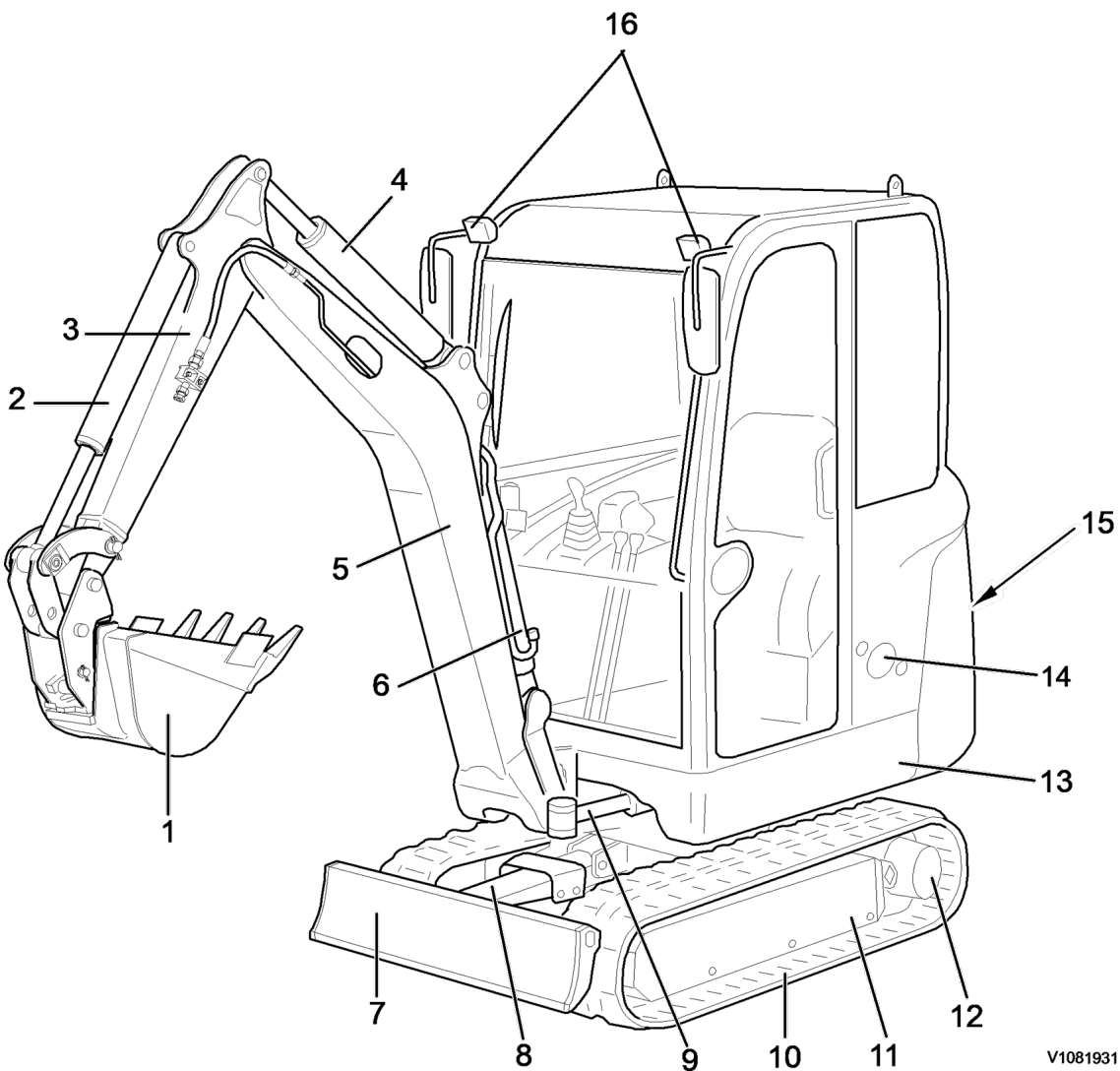

V1081931

Figure 1

Component locations

1	Bucket	9	Arm extension cylinder
2	Bucket cylinder	10	Track chain
3	Arm	11	Undercarriage
4	Dipper arm cylinder	12	Travel motor
5	Boom	13	Superstructure
6	Boom cylinder	14	Battery disconnection switch
7	Dozer blade	15	Engine hood
8	Dozer blade cylinder	16	Working light

Document Title: Volvo standard tightening torques	Function Group: 030	Information Type: Service Information	Date: 2018/4/14
Profile: EC15D Volvo			

Volvo standard tightening torques

Showing All Profiles

Valid for serial numbers			
Model	Production site	Serial number start	Serial number stop
EC15C Volvo			
EC15D Volvo			
EC17C Volvo			
EC18C Volvo			
EC18D Volvo			
EC20C Volvo			
EC20D Volvo			
EC27C Volvo			
EC35C Volvo			
ECR25D Volvo			
ECR28 Volvo			
ECR38 Volvo			
ECR48C Volvo			
ECR50D Volvo			

Tightening torques in the following tables refer to bolted joints with tensile strength according to the below. The tables should be regarded as general guidelines for tightening bolted joints where nothing else is specified.

NOTE!

Increase the values by 10% for flange bolt type U6FS. Bolts and nuts should be clean and lubricated with oil.

Metric coarse and fine threads, tensile strength class 8.8	Nm	kpm	lbf ft
M6	10 ±2	1,0 ±0,2	7,4 ±1,5
M8	24 ±5	2,4 ±0,5	18 ±3,5
M10	48 ±10	4,8 ±1,0	35 ±7,4
M12	85 ±18	8,5 ±1,8	63 ±13
M14	140 ±25	14,0 ±2,5	103 ±18
M16	220 ±45	22,0 ±4,5	160 ±33
M20	430 ±85	43,0 ±8,5	320 ±63
M24	740 ±150	74,0 ±15,0	550 ±110

Metric coarse and fine threads, tensile strength class 10.9	Nm	kpm	lbf ft
M6	12 ±2	1,2 ±0,2	9 ±1,5

M8	30 ±5	3,0 ±0,5	22 ±3,5
M10	60 ±10	6,0 ±1,0	44 ±7,4
M12	105 ±20	10,5 ±2,0	78 ±14,5
M14	175 ±30	17,5 ±3,0	130 ±22
M16	275 ±45	27,5 ±4,5	204 ±33
M20	540 ±90	54,0 ±9,0	400 ±66
M24	805 ±160	80,5 ±16,0	594 ±118

UNC-threads, pitch	coarse	Nm	kpm	lbf ft
1/4"		9 ±2	0,9 ±0,2	6,6 ±1,5
5/16"		18 ±4	1,8 ±0,4	13 ±3,0
3/8"		33 ±8	3,3 ±0,8	24 ±5,9
7/16"		54 ±14	5,4 ±1,4	40 ±10
1/2"		80 ±20	8,0 ±2,0	59 ±15
9/16"		120 ±30	12,0 ±3,0	89 ±22
5/8"		170 ±40	17,0 ±4,0	130 ±30
3/4"		300 ±70	30,0 ±7,0	220 ±52
7/8"		485 ±115	48,5 ±11,5	360 ±85
1"		725 ±175	72,5 ±17,5	530 ±130

Document Title: Standard tightening torques	Function Group: 030	Information Type: Service Information	Date: 2018/4/14
Profile: EC15D Volvo			

Standard tightening torques

Showing All Profiles

Valid for serial numbers			
Model	Production site	Serial number start	Serial number stop
EC15C Volvo			
EC15D Volvo			
EC17C Volvo			
EC18C Volvo			
EC18D Volvo			
EC20C Volvo			
EC20D Volvo			
EC27C Volvo			
EC35C Volvo			
ECR25D Volvo			
ECR48C Volvo			
ECR50D Volvo			

Hydraulic connections, general

Before fitting pipe couplings, plugs and hoses:

- Make sure that the sealing surfaces are clean and free from pores or scratches.
- Check elastic seal rings for defects.
- Oil in threads, sealing surfaces and contact surfaces except for ORFS-connections (ORFS = O-Ring Face Seal).

Nipples

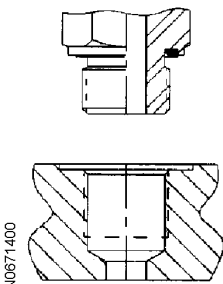
Valve connections, ORFS-connections with ED seals (DIN 3852 form E)		
		
Connection thread (mm)	Width across flats (mm)	Torque (Nm)
M10 x 1.0		19
M12 x 1.5	17	37
M14 x 1,5	22	58
M16 x 1,5	22	74
M18 x 1,5	24	94

M20 x 1.5		130
M22 x 1.5	27	140
M27 x 2.0	32	190
M33 x 2.0	41	330
M42 x 2.0	50	470
M48 x 2.0	55	570
Connection thread (inches)	Width across flats (mm)	Torque (Nm)
G 1/8	17 alt. 19	19
G 1/4	19 alt. 22	58
G 3/8	22 alt. 27	84
G 1/2	27 alt. 32	120
G 3/4	32 alt. 41	190
G 1	41 alt. 46	330
G 1 1/4	50	470
G 1 1/2	55	570

Valve connections, ORFS-connections with O-ring seals (ISO 6149)

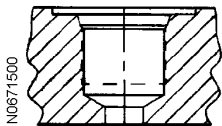
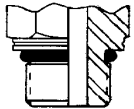

Connection thread (mm)	Width across flats (mm)	Torque (Nm)
M8 x 1.0		11
M10 x 1.0		21
M12 x 1.5	17 alt. 19	37
M14 x 1,5	19 alt. 22	47
M16 x 1,5	22	58
M18 x 1,5	24 alt. 27	74
M22 x 1.5	27 alt. 32	110
M27 x 2.0	32	180
M33 x 2.0	32, 41 alt. 46	330
M42 x 2.0	50	350
M48 x 2.0	55	440
Connection thread (inches)	Width across flats (mm)	Torque (Nm)
7/16 - 20 UNF	16	21
1/2 - 20 UNF		26
9/16 - 18 UNF	19	37
3/4 - 16 UNF	22	74
7/8 - 14 UNF	27	110
1 1/16 - 12 UNF	41	180
1 5/16 - 12 UNF	41	284
1 5/8 - 12 UNF	50	300
1 7/8 - 12 UNF	55	390

Blanking plugs

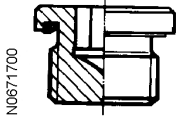
Blanking plugs with ED seal

Connection thread (mm)	Allen key dim. (mm)	Torque (Nm)
M10 x 1.0	5	12
M12 x 1.5	6	25
M14 x 1,5	6	35
M16 x 1,5	8	55
M18 x 1,5	8	65
M20 x 1.5	10	80
M22 x 1.5	10	90
M26 x 1.5	12	100
M27 x 2.0	12	140
M33 x 2.0	17	230
M42 x 2.0	22	360
M48 x 2.0	24	360
Connection thread (inches)	Allen key dim. (mm)	Torque (Nm)
G 1/8	5	13
G 1/4	6	30
G 3/8	8	60
G 1/2	10	80
G 3/4	12	140
G 1	17	200
G 1 1/4	22	400
G 1 1/2	24	450

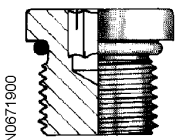
Blanking plugs with O-ring seal (ISO 6149)

Connection thread (mm)	Allen key dim. (mm)	Torque (Nm)
M10 x 1.0	5	20
M12 x 1.5	6	35
M14 x 1,5	6	45
M16 x 1,5	8	55
M18 x 1,5	8	70
M20 x 1.5	10	80
M22 x 1.5	10	100
M26 x 1.5	12	130
M27 x 2.0	12	170
M33 x 2.0	14	310
M42 x 2;0	22	330

ORFS-connections**ORFS-connections (ISO 8434-3)**

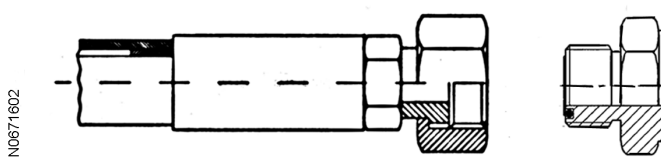

Thread size (in)	Width across flats (mm)	Tightening torque (Nm) *
9/16 - 18 UNF	17 alt. 19	25
11/16 - 16 UN	22	35
13/16 - 16 UN	24	55
1 - 14 UNS	30	85
1 3/16 - 12 UN	36	120
1 7/16 - 12 UN	41 alt. 46	160
1 11/16 - 12 UN	50	200
2 - 12 UN	60	260

* Threads and sealing surface must not be oiled in before tightening.

Hose clamps

Hose clamps with worms		
Intended for hose outside diameter (mm)	Width across flats (mm)	Torque (Nm)
10 - 19	7	2,5
20 - 30	7	3,5
31 - 49	7	4.5
50 - 231	7	5.5

Bolts and nuts

The pretension achieved at a particular tightening torque depends greatly on the coefficient of friction of the screw connection.

The coefficient of friction in turn depends on the surface finish and lubrication state. The values have been calculated on the assumption of a coefficient of friction of 0.2 for dry chromated flange screws and 0.15 for oiled chromated flange screws. The lower torque for socket head and traditional hex bolts is due to the shorter lever moment below the screw head (smaller head diameter) compared with flange bolts.

The following abbreviations for surface treatment are used in the tables:

- Fe/Zn-Fe = Black chromated zinc - iron
- FZB = Blank chromated

NOTE!

In some body parts, there are weld bolts with much lower strength than normal bolts of the same dimension.

NOTE!

When Nordloc washer is used, increase the torque by 20%.

NOTE!

Bolts provided with liquid alt. micro-capsuled thread locker or thread sealant shall be tightened with the same torque as a lubricated bolt of the same type.

Flange bolts	
	Blind rivet nut

Threads. (mm)	Width across flats (mm)	Torque (Nm)				Torque (Nm)
		8.8 Fe/Zn-Fe dry	8.8 Fe/Zn-Fe Oiled	10.9 Phosphated	10.9 Phosphated Oiled	
						Dry
M5	8	7	6			6
M6	10	12	10			10
M8	12	28	24			24
M10	14	56	48	70	60	48
M12	17	100	85	125	105	82
M14	18	160	140	200	175	
M16	21	250	220	320	275	

Hex bolts and Allen head bolts							Blind rivet nut
Threads. (mm/inch)	Wrench size (width across flats)		Torque (Nm)				
	Hexagon (mm/inch)	Wrench socket (mm/inch)	8.8 FZB & Fe/Zn-Fe Dry	8.8 FZB & Fe/Zn-Fe Oiled	10.9 Phosphated Oiled	12.9 Untreated Oiled	
M5	8	4	6	5			6
M6	10	5	10	9		20	10
M8	13	6	25	22		40	24
M10	16	8	50	44	60	80	48
M12	18	10	90	75	105	140	82
M14	21	12	140	125	175	220	
M16	24	14	220	190	275	340	
M20	30	17	450	380	540	650	
M24	36	19	770	660	900	1 120	
M27	41	-	1 100	940	1 350	1 620	
M30	46	22	1 500	1 280	1 840	2 210	
M36	55		2 500	2 300	3 210	3 850	
1/4 UNC	7/16	3/16	12	10	15	20	
5/16 UNC	1/2	1/4	25	21	30	40	
3/8 UNC	9/16	5/16	45	38	55	70	
7/16 UNC	5/8		65	55	90		
1/2 UNC	3/4	3/8	100	85	130	170	
9/16 UNC	13/16		145	123	190		

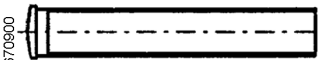
Nuts on weld bolts (material S235JRG2-EN 10025)	
	
Threads.	Tightening torque

	(Nm)
M6	5
M8	12

Tolerances

Modern high-quality torque wrenches normally give a variation of $\pm 5\%$ of the indicated value. This, together with variations in friction coefficient, gives a range in the pretensioning force of approximately $\pm 16\%$ for lubricated bolted joints and $\pm 29\%$ for dry bolted joints.

Document Title: Conversion tables	Function Group: 030	Information Type: Service Information	Date: 2018/4/14
Profile: EC15D Volvo			

Conversion tables

Showing All Profiles

Valid for serial numbers			
Model	Production site	Serial number start	Serial number stop
EC15C Volvo			
EC15D Volvo			
EC17C Volvo			
EC18C Volvo			
EC18D Volvo			
EC20C Volvo			
EC20D Volvo			
EC27C Volvo			
EC35C Volvo			
ECR25D Volvo			
ECR28 Volvo			
ECR38 Volvo			
ECR48C Volvo			
ECR50D Volvo			

Length

Unit	cm	m	km	in	ft	yd	mile
cm	1	0.01	0.00001	0.3937	0.03281	0.01094	0.000006
m	100	1	0.001	39.37	3.2808	1.0936	0.00062
km	100000	1000	1	39370.7	3280.8	1093.6	0.62137
in	2.54	0.0254	0.000025	1	0.08333	0.02777	0.000015
ft	30.48	0.3048	0.000304	12	1	0.3333	0.000189
yd	91.44	0.9144	0.000914	36	3	1	0.000568
mile	160930	1609.3	1.6093	63360	5280	1760	1

1 mm = 0.1 cm - 1 mm = 0.001 m

Area

Unit	cm ²	m ²	km ²	a	ft ²	yd ²	in ²
cm ²	1	0.0001	-	0.000001	0.001076	0.000012	0.155000
m ²	10000	1	0.000001	0.01	10.764	1.1958	1550.000
km ²	-	1000000	1	10000	1076400	1195800	-
a	0.01	100	0.0001	1	1076.4	119.58	-
ft ²	-	0.092903	-	0.000929	1	0.1111	144.000
yd ²	-	0.83613	-	0.008361	9	1	1296.00

in ²	6.4516	0.000645	-	-	0.006943	0.000771	1
1 ha = 100 a - 1 mile ² = 259 ha = 2.59 km ²							

Volume

Unit	cm ³ = cc	m ³	l	in ³	ft ³	yd ³
cm ³ = ml	1	0.000001	0.001	0.061024	0.000035	0.000001
m ³	1000000	1	1000	61024	35.315	1.30796
dm ³ (l)	1000	0.001	1	61.024	0.035315	0.001308
in ³	16.387	0.000016	0.01638	1	0.000578	0.000021
ft ³	28316.8	0.028317	28.317	1728	1	0.03704
yd ³	764529.8	0.76453	764.53	46656	27	1
1 gal (US) = 3785.41 cm ³ = 231 in ³ = 0.83267 gal (UK)						

Weight

Unit	g	kg	t	oz	lb
g	1	0.001	0.000001	0.03527	0.0022
kg	1000	1	0.001	35.273	2.20459
t	1000000	1000	1	35273	2204.59
oz	28.3495	0.02835	0.000028	1	0.0625
lb	453.592	0.45359	0.000454	16	1
1 ton (metric) = 1.1023 ton (US) = 0.9842 ton (UK)					

Pressure

Unit	kp/cm ²	bar	Pa=N/m ²	kPa	lbf/in ²	lbf/ft ²
kp/cm ²	1	0.98067	98066.5	98.0665	14.2233	2048.16
bar	1.01972	1	100000	100	14.5037	2088.6
Pa=N/m ²	0.00001	0.001	1	0.001	0.00015	0.02086
kPa	0.01020	0.01	1000	1	0.14504	20.886
lbf/in ²	0.07032	0.0689	6894.76	6.89476	1	144
lbf/ft ²	0.00047	0.00047	47.88028	0.04788	0.00694	1
kg/cm ² = 735.56 Dry (mmHg) = 0.96784 atm						

Unit explanations

Unit	abbreviation
Newton meter	Nm
Kilopoundmeter	kpm
Kilopascal	kPa
Megapascal	MPa
Kilowatt	kW
kilojoule	kJ
British thermal unit	Btu
Calorie	ca

Approx. conversion

SI unit	Conversion factor	Non SI	Conversion factor	SI

Torque				
Nm	x10.2	=kg/cm	x0.8664	=lb in
Nm	x0.74	=lbf·ft	x1.36	=Nm
Nm	x0.102	=kg/m	x7.22	=lbft
Pressure (Pa = N/m²)				
kPa	x4.0	=in.H ₂ O	x0.249	=kPa
kPa	x0.30	=in.Hg	x3.38	=kPa
kPa	x0.145	=psi	x6.89	=kPa
bar	x14.5	=psi	x0.069	=bar
kp/cm ²	x14.22	=psi	x0.070	=kp/cm ²
N/mm ²	x145.04	=psi	x0.069	=bar
MPa	x145	=psi	x0.00689	=MPa
Power (W = J/s)				
kW	x1.36	=hp(cv)	x0.736	=kW
kW	x1.34	=bhp	x0.746	=kW
kW	x0.948	=Btu/s	x1.055	=kW
W	x0.74	=ft·lb/s	x1.36	=W
Energy (J = Nm)				
kJ	x0.948	=Btu	x1.055	=kJ
J	x0.239	=calorie	x4.19	=J
Speed and acceleration				
m/s ²	x3.28	=ft/s ²	x0.305	=m/s ²
m/s	x3.28	=ft/s	x0.305	=m/s
km/h	x0.62	=mph	x1.61	=km/h
Horsepower/torque				
Bhp x5252 rpm= TQ (lb·ft)			TQ x rpm 5252=bhp	
Temperature				
°C =(°F-32)/1.8			°F =(°C x1.8) +32	
Flow factor				
l/min (dm ³ /min)	x0.264	= US gal/min	x3.785	=liter/min

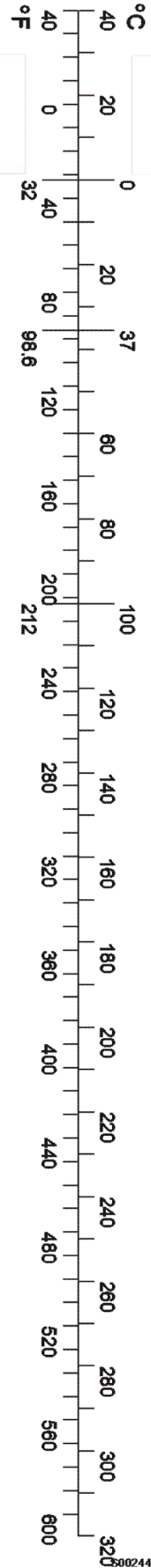

Figure 1

Document Title: Dimensions	Function Group: 030	Information Type: Service Information	Date: 2018/4/14
Profile: EC15D Volvo			

Dimensions

Showing Selected Profile

Valid for serial numbers			
Model	Production site	Serial number start	Serial number stop
EC15D Volvo			

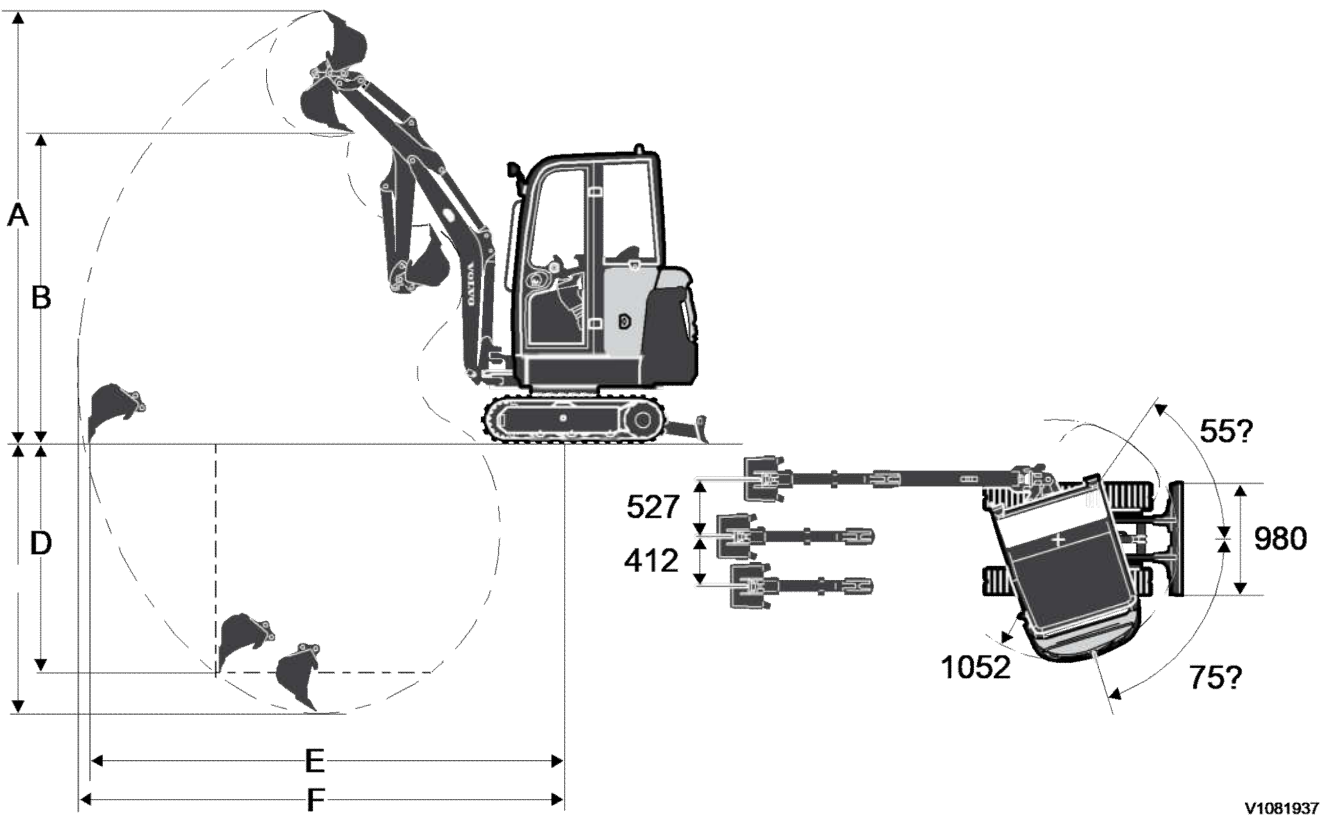

V1081937

Figure 1
Dimensions

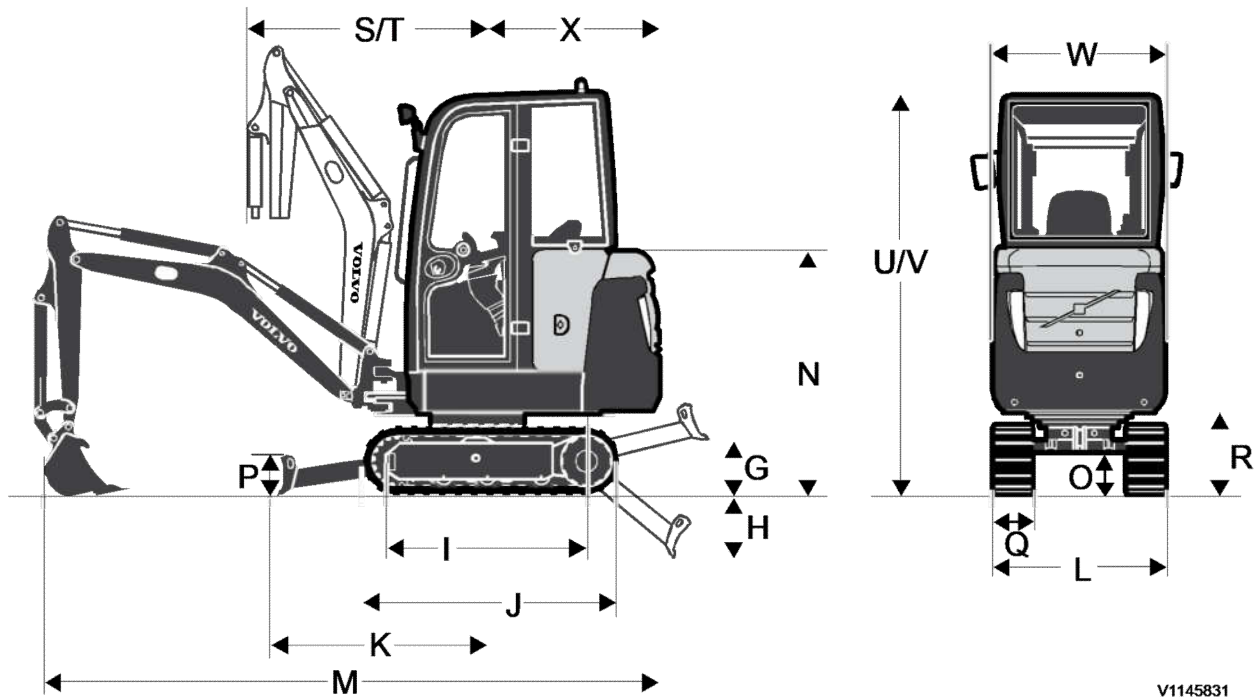

V1145831

Figure 2
Dimensions

The letters in the figures refer to the table below.

Version	EC15D	
Arm	950 mm (37.40 in)	1150 mm (45.28 in)
A	3437 mm (135.31 in)	3580 mm (140.94 in)
B	2475 mm (97.44 in)	2620 mm (103.15 in)
C*	2120 mm (83.46 in)	2323 mm (91.46 in)
D	1793 mm (70.59 in)	1985 mm (78.15 in)
E	3803 mm (149.72 in)	3996 mm (157.26 in)
F	3856 mm (151.81 in)	4046 mm (159.29 in)
G	209 / 321 mm (8.23 / 12.64 in)	
H	190 / 294 mm (7.48 / 11.57 in)	
I	1082 mm (42.60 in)	
J	1462 mm (57.56 in)	
K	857 / 1166 mm (33.74 / 45.91 in)	
L	980 mm (38.58 in)	
M	3580 mm (140.9 in)	3472 mm (136.7 in)
N	1400 mm (55.12 in)	
O	210 mm (8.27 in)	
P	238 / 241 mm (9.37 / 9.49 in)	
Q	Rubber 230 mm (9.06 in)	
R	458 mm (18.03 in)	
S	1452 mm (57.17 in)	1471 mm (57.91 in)
T	1147 mm (45.16 in)	1164 mm (45.83 in)
U	2296 mm (90.39 in)	
V	2371 mm (93.35 in)	
W	993 mm (39.1 in)	
X	1052 mm (41.4 in)	

Total swivel angle	360°
--------------------	------

*: Excavation depth with blade lowered to floor

NOTE!

The machine specifications are given for information only and may be amended by the manufacturer at any time without prior notice.

Please Click Here To Download The Complete Manual
Download Other Manuals
If Having Any Questions Feel Free To Contact us

admin@servicemanualbit.com