

8025Z, 8030Z, 8035Z

[Section 1 - General Information](#)

[Section 2 - Care and Safety](#)

[Section 3 - Maintenance](#)

[Section A - Attachments](#)

[Section B - Body and Framework](#)

[Section C - Electrics](#)

[Section D - Body and Framework](#)

[Section E - Hydraulics](#)

[Section F - Gearboxes](#)

[Section J - Track and Running Gear](#)

[Section K - Engine](#)

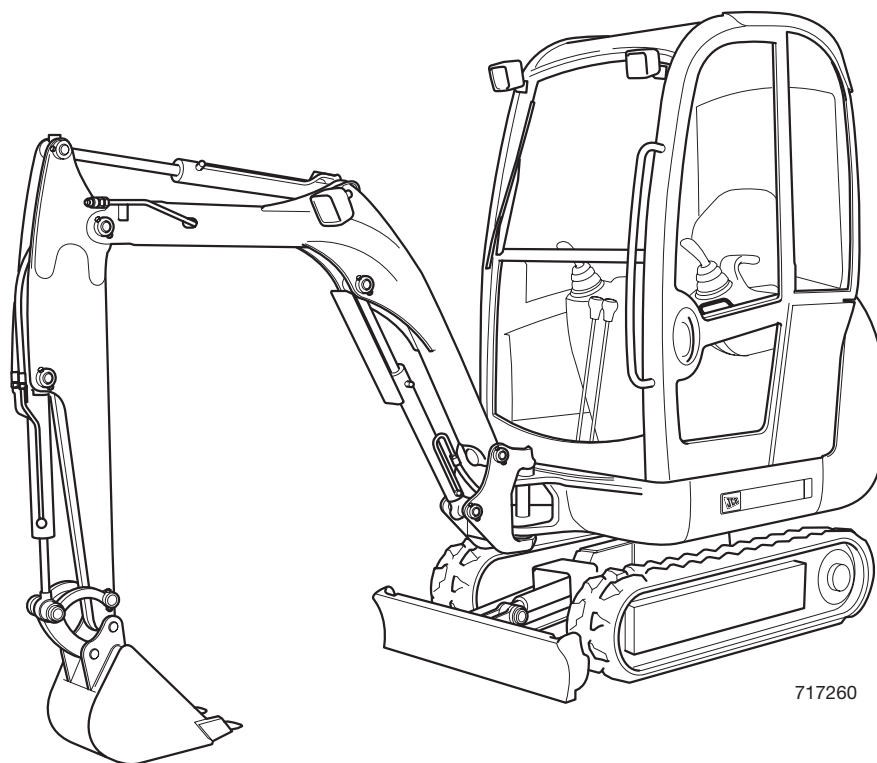

Publication No.
9803/9410-3



Copyright © 2004 JCB SERVICE. All rights reserved. No part of this publication may be reproduced, stored in a retrieval system, or transmitted in any form or by any other means, electronic, mechanical, photocopying or otherwise, without prior permission from JCB SERVICE.



Notes:

General Information

[Section 1 - General Information](#)

[Section 2 - Care and Safety](#)

[Section 3 - Maintenance](#)

[Section A - Attachments](#)

[Section B - Body and Framework](#)

[Section C - Electrics](#)

[Section D - Body and Framework](#)

[Section E - Hydraulics](#)

[Section F - Gearboxes](#)

[Section J - Track and Running Gear](#)

[Section K - Engine](#)

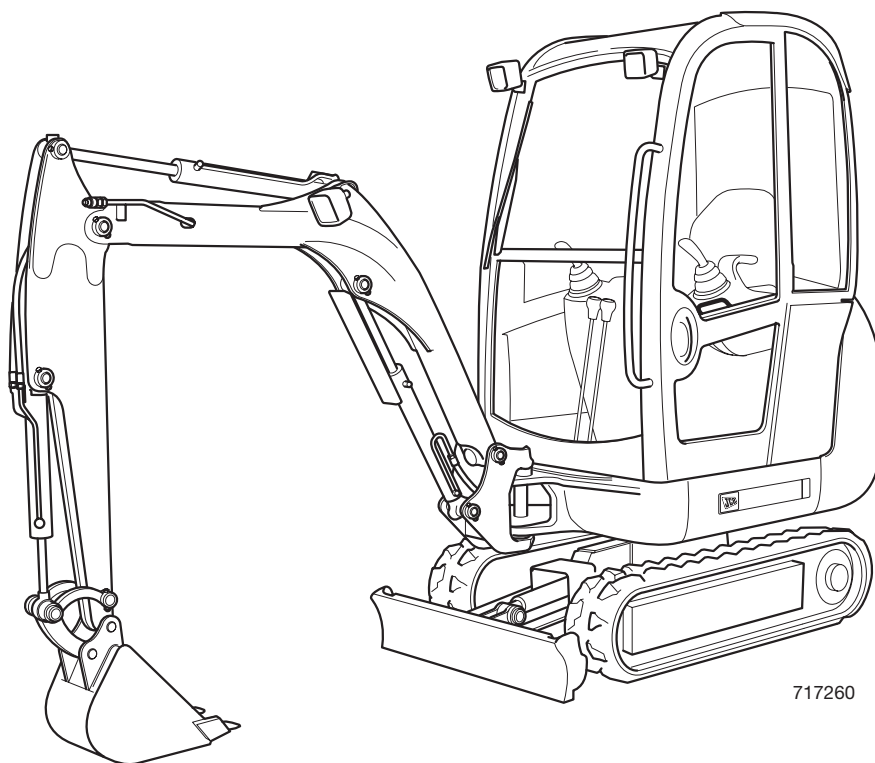

Publication No.
9803/9410-3



Copyright © 2004 JCB SERVICE. All rights reserved. No part of this publication may be reproduced, stored in a retrieval system, or transmitted in any form or by any other means, electronic, mechanical, photocopying or otherwise, without prior permission from JCB SERVICE.



Notes:



Contents	Page No.
Introduction	
About this Manual	1-1
Machine Model and Serial Number	1-1
Using the Service Manual	1-1
Section Numbering	1-1
Units of Measurement	1-1
Left Side, Right Side	1-2
Cross References	1-2
Identifying Your Machine	
Identification Plates	1-3
Data Plate	1-3
Typical Product Identification Number (VIN)	1-3
Typical Engine Identification Number	1-3
ROPS, TOPS and FOGS	1-4
Standard Torque Settings	
Zinc Plated Fasteners and Dacromet Fasteners	1-5
Introduction	1-5
Bolts and Screws	1-5
Hydraulic Connections	1-9
'O' Ring Face Seal System	1-9
'Torque Stop' Hose System	1-12
Service Tools	
Numerical List	1-13
Tool Detail Reference	1-16
Section B - Frame and Bodywork	1-16
Section C - Electrics	1-20
Section E - Hydraulics	1-21
Section K - Engine	1-26
Service Consumables	
Sealing and Retaining Compounds	1-27
Terms and Definitions	
Colour Coding	1-29
Hydraulic Schematic Colour Codes	1-29

Please Click Here To Download The Complete Manual
Download Other Manuals
If Having Any Questions Feel Free To Contact us

admin@servicemanualbit.com