

PARTS MANUAL

**E45Z, E50Z, E55Z, E60Z, E65Z
(G108)**

CUSTOMER EDITION

HYSTER

SECTIONS

1	FRAME
2	ELECTRICAL SYSTEM
3	DRIVE UNIT
4	STEERING SYSTEM
5	BRAKE/ACCELERATOR SYSTEM
6	HYDRAULIC SYSTEM
7	MAST-TWO STAGE LIMITED FREE-LIFT
8	MAST-THREE STAGE FULL FREE-LIFT
9	MAST-TWO STAGE FULL FREE-LIFT
10	MAST-FOUR STAGE FULL FREE-LIFT
11	OPTIONS
12	NUMERICAL INDEX

This Parts Manual is divided into 12 major sections which are listed above. Quick reference to these sections can be made by placing the right thumb on the tab of the desired section, bending the book back and thumbing the pages to the corresponding tab.

TABLE OF CONTENTS

DESCRIPTION	PAGE
A	
ACCELERATOR	5-16
ACCELERATOR PEDAL.....	5-18
AUXILIARY TUBES	
FOUR STAGE FULL FREE-LIFT	
FOUR FUNCTION GROUP	11-16
TWO AND THREE STAGE FULL FREE-LIFT	
FOUR FUNCTION GROUP	11-14
B	
BACKUP ALARM	11-30
BATTERY SLIDE AND ROLLER TRAY	11-18
BRAKE	5-6
BRAKE AND BACKUP LIGHT	11-22
BRAKE PEDAL LINKAGE	5-2
BRAKE SWITCH HARNESS.....	5-20
C	
CARRIAGE	
FOUR STAGE FULL FREE-LIFT	10-22
SIX ROLLER	
THREE STAGE FULL FREE-LIFT	8-34
TWO STAGE FULL FREE-LIFT	9-20
TWO STAGE LIMITED FREE-LIFT	7-18
CONTACTOR	
LINE	2-12
POWER STEERING	2-14
CONTACTOR PANEL	
CONTACTOR (LINE AND POWER STEERING).....	2-10
CONTACTOR HYDRAULIC	2-16
CONTROL PANEL	
CONTACTOR HYDRAULIC	2-8
TRACTION AND PUMP CONTROLLER	2-6
CONTROL VALVE	
FOUR FUNCTION	6-30
THREE FUNCTION	6-26
CONTROL VALVE ATTACHING PARTS.....	6-20
COUNTERWEIGHT	1-14
COVERS	1-6
D	
DASH DISPLAY	2-5
DC CONVERTOR	
36/48 VOLT TO 12 VOLT	11-29
DRIVE AND REAR LIGHTS	11-24
DRIVE AXLE	3-2
DRIVE UNIT INSTALLATION	
E/EE/ES AND CRE/FRE.....	3-8

TABLE OF CONTENTS (Continued)

DESCRIPTION	PAGE
E	
ELECTRICAL	2-2
F	
FORK.....	1-30
FRAME	1-2
FREE-LIFT	
E45-55Z	
TWO STAGE FULL FREE-LIFT	9-8
E60-65Z	
TWO STAGE FULL FREE-LIFT	9-10
FOUR STAGE FULL FREE-LIFT	10-12
THREE STAGE FULL FREE-LIFT	8-18
FREE-LIFT CYLINDER	
FOUR STAGE FULL FREE-LIFT	10-20
THREE STAGE FULL FREE-LIFT	8-30
TWO STAGE FULL FREE-LIFT	9-17
FULL SUSPENSION SEAT	
SHEET 1 OF 2	1-20
SHEET 2 OF 2	1-22
G	
GEAR PUMP	4-12
H	
HAND LEVER.....	6-24
HEADER HOSE	
FOUR STAGE FULL FREE-LIFT	10-24
THREE STAGE FULL FREE-LIFT	8-36
TWO STAGE FULL FREE-LIFT	9-22
TWO STAGE LIMITED FREE-LIFT	7-20
HOOD.....	1-8
HYDRAULIC	6-2
HYDRAULIC MOTOR.....	6-12
CLOSED CONSTRUCTION	6-16
OPEN CONSTRUCTION	6-14
HYDRAULIC MOTOR MOUNT.....	6-10
HYDRAULIC PUMP	
12 CC.....	6-5
19 CC.....	6-8
LOW NOISE	
19 CC	6-6
HYDRAULIC TANK.....	6-34
I	
INNER MAST	
FOUR STAGE FULL FREE-LIFT	10-8
THREE STAGE FULL FREE-LIFT	8-10
TWO STAGE FULL FREE-LIFT	9-4
TWO STAGE LIMITED FREE-LIFT	7-4
INTEGRAL SIDE-SHIFT	

TABLE OF CONTENTS (Continued)

DESCRIPTION	PAGE
I (continued)	
CARRIAGE	
THREE STAGE FULL FREE-LIFT	11-4
TWO AND FOUR STAGE FULL FREE-LIFT	11-6
TWO STAGE LIMITED FREE-LIFT	11-2
HYDRAULIC HOSES	
THREE STAGE FULL FREE-LIFT	11-11
TWO AND FOUR STAGE FULL FREE-LIFT	11-12
TWO STAGE LIMITED FREE-LIFT	11-10
INTEGRAL SIDE-SHIFT CYLINDER	11-8
INTERMEDIATE MAST	
NO. 1	
FOUR STAGE FULL FREE-LIFT	10-4
NO. 2	
FOUR STAGE FULL FREE-LIFT	10-6
THREE STAGE FULL FREE-LIFT	8-6
L	
LABELS	1-25
LIFT	
TWO STAGE LIMITED FREE-LIFT	7-8
LIFT CYLINDER	
E45-55Z	
TWO STAGE LIMITED FREE-LIFT	7-11
E60-65Z	
TWO STAGE LIMITED FREE-LIFT	7-14
LOAD BACKREST EXTENSION	1-28
M	
MAIN CYLINDER	
LEFT HAND	
FOUR STAGE FULL FREE-LIFT	10-15
RIGHT HAND	
FOUR STAGE FULL FREE-LIFT	10-18
THREE STAGE FULL FREE LIFT	
LEFT HAND	8-26
THREE STAGE FULL FREE-LIFT	
RIGHT HAND	8-22
MAIN LIFT	
FOUR STAGE FULL FREE-LIFT	10-10
THREE STAGE FULL FREE-LIFT	8-14
TWO STAGE FULL FREE-LIFT	9-6
MAIN LIFT CYLINDER	
LEFT HAND	
TWO STAGE FULL FREE-LIFT	9-13
RIGHT HAND	
TWO STAGE FULL FREE-LIFT	9-15
MAST INSTALLATION	6-36
MASTER CYLINDER	5-4

TABLE OF CONTENTS (Continued)

DESCRIPTION	PAGE
N	
NON-SUSPENSION SEAT	1-16
O	
OUTER MAST	
FOUR STAGE FULL FREE-LIFT	10-2
THREE STAGE FULL FREE-LIFT	8-2
TWO STAGE FULL FREE-LIFT	9-2
TWO STAGE LIMITED FREE-LIFT	7-2
OVERHEAD GUARD	1-12
P	
PARK BRAKE	
SEAT ACTUATED	5-14
PARK BRAKE LINKAGE	
LEVER ACTUATED	5-8
SEAT ACTUATED	5-12
S	
SHIFT LEVER	4-4
SPOTLIGHT	11-28
STEERING AXLE	4-16
STEERING CONTROL UNIT	4-6
STEERING CYLINDER	4-10
STEERING HYDRAULIC	4-8
STEERING MOTOR	4-14
STEERING POD	4-2
STROBE LIGHT	11-26
SUSPENSION SEAT	1-18
T	
TILT CYLINDER	6-18
TIRE AND WHEEL	
DRIVE WHEEL	3-12
STEER WHEEL	4-18
TRACTION MOTOR	
11.0-INCH	3-10
TRANSMISSION AND DIFFERENTIAL	3-4
W	
WIRE HARNESS	
LIGHT	2-20
MAIN	2-18
REAR LIGHTS	11-32
SWITCH	11-33
TRACTION CUT-OUT	11-34

ABBREVIATIONS QUICK REFERENCE SHEET

Listed below are abbreviations used in parts manuals to denote the following expressions:

TERM	DEFINITION	TERM	DEFINITION
Amp	Amperes	FRE	Freezer Environment
AR	As Required	in.	inches
BDI	Battery Discharge Indicators	LPG	Liquefied Petroleum Gas
BWI	Brush Wear Indicator	MAP	Manifold Absolute Pressure
CE	Communicator End	mm	millimeters
CRE	Corrosive Environment	MSTS	Microprocessor Spark Timing System
D/B	Date Break	NPT	National Pipe Threads
dbA	Decibel "A" Scale	O/S	Oversize
DE	Drive End	PTO	Power Take Off
ECH	Empty Container Handler	RPM	Revolutions per Minute
ECH-3	Empty Container Handler - 3 High Stacking	S/N	Serial Number
ECH-4	Empty Container Handler - 4 High Stacking	TMM	Truck Management Module
ECH-5	Empty Container Handler - 5 High Stacking	UL Type D	Diesel-Powered Safety Rating
ECH-6	Empty Container Handler - 6 High Stacking	UL Type DS	Diesel-Powered Safety Rating
ECH-7	Empty Container Handler - 7 High Stacking	UL Type E	Battery-Powered Safety Rating
ECM	Electronic Control Module	UL Type EE	Battery-Powered Safety Rating
ECN	Engineering Change Notice	UL Type ES	Battery-Powered Safety Rating
EEPROM	Electrically Erasable Programmable Read Only Memory	UL Type G	Gasoline-Powered Safety Rating
EPROM	Electrically Programmable Read Only Memory	UL Type GS	Gasoline-Powered Safety Rating
		UL Type LP	Gas-Powered Safety Rating
		UL Type LPS	LP Gas-Powered Safety Rating
		U/S	Undersize
		UL	Underwriters Laboratory
		V	Volts

HOW TO USE THE ILLUSTRATED PARTS MANUAL

This parts manual describes and illustrates assemblies, subassemblies, and detail parts needed for service replacement.

The different constructions are indicated by keys and footnotes. The callouts correspond to descriptions found on the the next page.

HYSTER UNIT CODE D001 NORTH AMERICA 06/2001

TABLE OF CONTENTS

DESCRIPTION	PAGE
AIR INTAKE AND FILTER DIESEL (⇒ D/B 11/96).....	3-22
AIR INTAKE AND FILTER DIESEL (D/B 11/96 ⇒).....	
AIR INTAKE AND FILTER GASOLINE AND LPG.....	
ALTERNATOR GASOLINE, LPG, AND DIESEL -	
ALTERNATOR TYPES GS, LPS, AND DS.....	
AUXILIARY FUNCTION TUBE TWO AND THREE STAGE FULL F.....	

SECTION 13 NUMERICAL INDEX

PART NO.	ITEM PAGE NO.	PART NO.	ITEM PAGE NO.	PART NO.	ITEM PAGE NO.	PART NO.	ITEM PAGE NO.
142	3-4 19	10-13	25	11-27	29	12-31	12
12445	3-32 19	10-17	6	11-31	25	16719	3-35 5
	3-34 1	10-27	11	11-32	37	16751	3-18 27
		11-11	6	8-4	29	16845	3-34 21
		11-11	6	8-4	45		3-36 20
		12-21	11	8-8	34	16863	3-26 17
		4	13	9-7	9	16865	3-6 18
		12	6	9-7	19	16882	9-7 30
		3	17	9-11	9		9-11 27
		23	46	10-9	21		10-10 36
		27	46	10-9	28		10-13 32
		26	14	10-13	16		11-7 24
		28	14	11-7	18		11-9 17
		30	14				

SECTIONS

- 1
- 2
- 3
- 4
- 5
- 6
- 7
- 8
- 9
- 10
- 11

TRANSMISSION HOUSING ⇒ S/N D001H-2628

KEY:
A: Diesel
B: Gasoline and LPG

ITEM	PART NO.	DESCRIPTION	QTY	
			A	B
		Transmission	1	1
	2022547	Transmission	1	1
	2023329	Transmission	2	2
	2021670	Case	4	4
1	2023419	Bearing Cap	4	4
2	296426	Washer	1	1
3	293592	Bolt	2	2
4	2021390	Cover	4	4
5	1371655	Collar Pin	1	1
6	2021329	O-Ring	4	4
7	2021915	Plug	1	1
8	2021675	Housing	22	22
9	2021336	Pin	39	39
10	287880	Bolt	1	1
11	292682	Lockwasher	1	1
12		Hydraulic Pump	1	1
13		⇒ Figure 5-3	8	8
14	2021345	Gasket	1	1
15	214364	Bolt	8	8
16	256418	Washer	1	1
17	2021388	Temperature Switch	1	1
18	2021389	Breather	9	9
19	2021383	Dipstick	9	9
20	292515	Bolt	2	2
21	136692	Nut	3	3
22	292527	Bolt	2	2
23	292531	Capcrew	3	3
24	292683	Lockwasher	4	4
25	293837	Bolt	4	4
26	296420	Washer	1	1
	996403	Transmission Kit (Includes Item 7)	1	1
	996405	Transmission Kit (Includes Item 14)	1	1

This Parts Manual is divided into 11 major sections which are listed above. Quick access can be made by placing the right thumb on the tab of the desired section, bending the pages to the corresponding tab.

© Copy Right Date HYSTER COMPANY See Service Manual for service procedures. 5-15

HP990004

HOW TO FIND THE DESIRED PART NUMBER

WHEN THE PART NUMBER AND THE NEXT HIGHER ASSEMBLY IS NOT KNOWN:

1. Determine the function and application of the part required. Turn to the Sections Page. Choose the general area of reference most likely to include the part.
2. Turn to the section you chose. Use the Section Table of Contents to determine the assembly which would normally contain the part required. Then locate the part on the assembly breakdown page.

WHEN THE PART NUMBER IS NOT KNOWN AND THE NEXT HIGHER ASSEMBLY IS KNOWN:

3. Determine the assembly the required part is used on. Turn to the Table of Contents on Page i.
4. Locate the assembly the required part is used on and turn to the page indicated for that assembly. Then locate the part on the assembly breakdown page.

WHEN THE PART NUMBER IS KNOWN:

5. Use the Numerical Index on Page 12-1 to find the part number. Turn to the page listed and locate the part as indicated by the item number.

GENERAL:

The assembly breakdowns include part numbers, descriptions, quantities required, keys and footnotes to help in selecting correct parts.

6. Five periods in the PART NO. column (.) indicate that the part is either *Not Serviced Separately* or there is a reference to another figure. A figure reference is denoted by a pointing hand followed by a figure number in the DESCRIPTION column (☞ Figure 10)
7. Keys are used to show two or more similar assemblies, RH and LH assembly parts, etc. Select the appropriate key, "A", "B", "C", "D", or "E" and the corresponding quantity column to find the required parts. Two periods in the QTY column (..) indicate that the part is not used for that assembly.
8. Indented descriptions under the DESCRIPTION column are used to indicate assemblies and subparts of assemblies. In the example on the

previous page, *BEARING CAP* (Item 2) is a subpart of the major assembly *CASE*.

9. Quantities shown are for one assembly. The quantities of the subpart *BEARING CAP* are indicated as two and two. This means two per *CASE* assembly.
10. Serial number breaks identify the most current parts information and are shown as follows:
 - ⇒ **S/N D001H-2628**
Indicates last serial number affected.
 - S/N D001H-2629** ⇒
Indicates the first serial number affected.
 - S/N D001H-1553 ⇔ S/N D001H-3291**
Indicates a range of serial numbers affected.

ECN numbers for pending serial numbers are shown to allow for the inclusion of the most current parts information and are identified as follows:

- ⇒ **S/N Pending Per ECN 63243**
Indicates a pending serial number for last unit affected.
- S/N Pending Per ECN 63243** ⇒
Indicates a pending serial number for first unit affected.

Date breaks are used to indicate when a change occurred but a subsequent serial number break was not recorded. This is an arbitrary date usually based on the ECN release and are identified as follows:

- ⇒ **D/B 3/00**
Indicates that a change occurred sometime within that month for the item affected.
- D/B 3/00** ⇒
Indicates that a change occurred sometime within that month for the item affected.
- D/B 3/00 ⇔ D/B 4/00**
Indicates a range of production dates of the item affected.

Contact your local dealer for Hyster lift trucks for serial number information for items with a ECN or a date break.

ORDERING PARTS:

When ordering replacement parts, give the unit serial number, part number, name of part and quantity required.

For any further information on parts, service, or ordering, consult your local dealer for Hyster lift trucks.

IDENTIFICATION OF TRUCK SERIAL NUMBERS

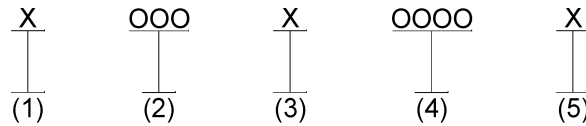

- (1) and (2) The first letter and three numbers indicate the truck unit code.
- (3) The second letter indicates the plant of manufacture.
- (4) The four or five digit number indicates the production sequence number of the truck.
- (5) The final letter indicates the year of manufacture starting with "A" in 1957 and 1980. The letters "I", "O", and "Q" will not be used.

For pending serial numbers contact your local dealer for Hyster lift trucks.

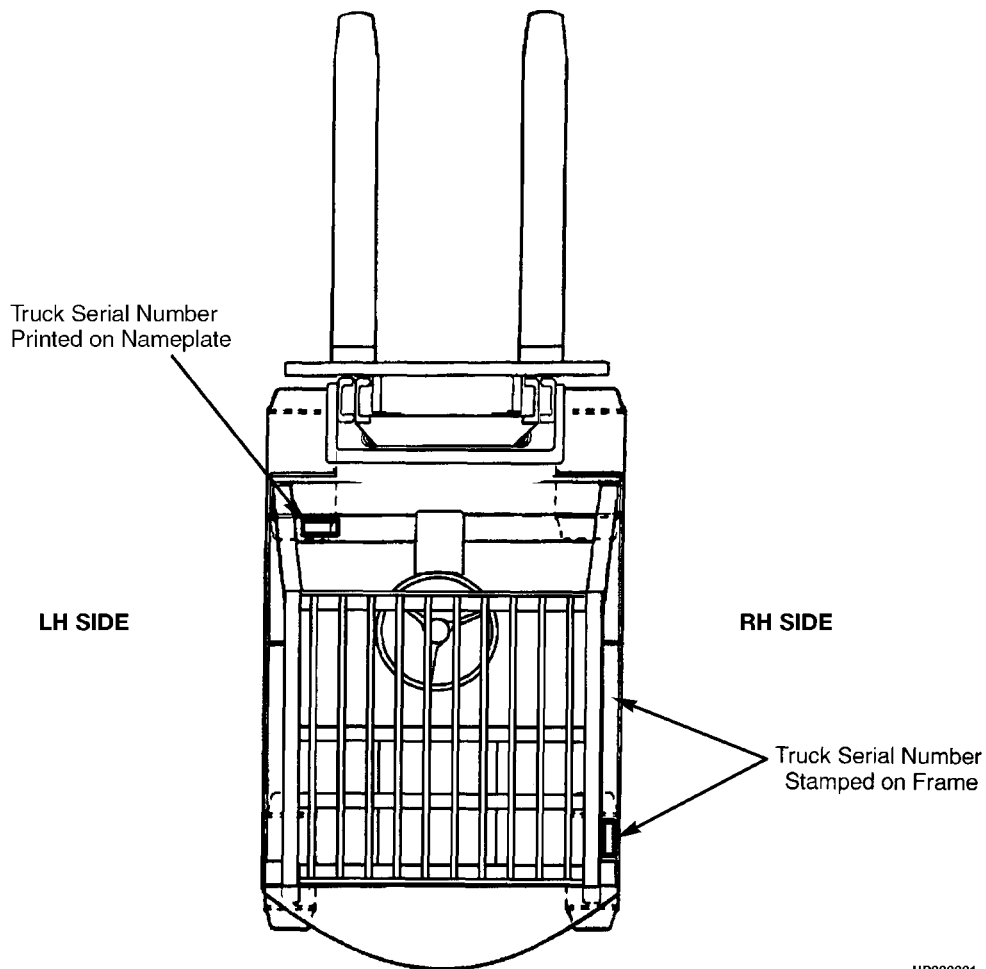

Parts referred to in this book as right or left hand parts are in accordance with the illustration above.

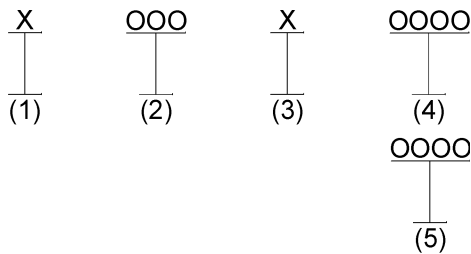
IDENTIFICATION OF MAST SERIAL NUMBERS

- (1) and (2) The first letter and number indicates the mast unit code.
- (3) The second letter indicates the plant of manufacture.
- (4) The four or five digit number indicates the production sequence number of the mast.
- (5) Carriage travel in millimeters stamped just below the serial number.

Mast Group identification consists of mast unit code (1) and (2) plus carriage travel (5).

For pending production sequence numbers contact your local dealer for Hyster lift trucks.

LIFT EQUIPMENT IDENTIFICATION

1. Fork part number, capacity rating, plant code letter, and date of manufacture are stamped approximately six inches below the top of most forks.
2. The carriage group number is stamped on the right hand side of the top crossmember (pin type) or on the back of the right hand end of the bottom crossmember (hook type). A date code has two letters in line with or below the carriage group number.
3. The mast identification number has a unit code, a letter indicating the plant of manufacture, and a serial number. Underneath the production sequence number is a four digit number that indicates the carriage travel in millimeters.
4. Tilt and lift cylinder group numbers are stamped on the cylinder shell.

Always refer to the group, serial, or part number when ordering service parts.

Modification of masts and carriages by SPED (Special Products Engineering Department) are identified by a model prefix code beginning with the letter "S". contact your dealer for Hyster lift trucks for information on these assemblies.

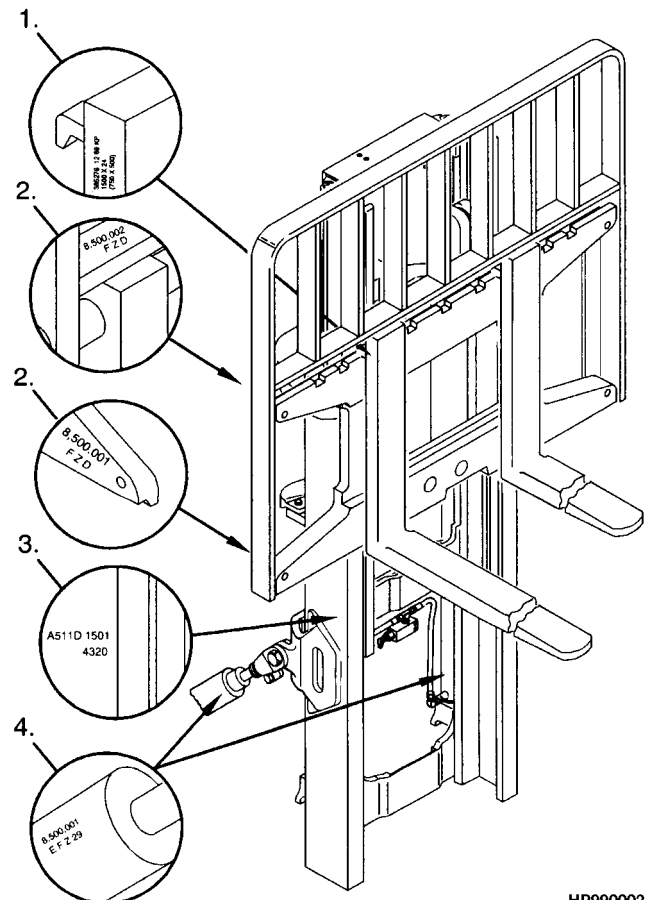

HP990002

IDENTIFICATION OF ATTACHMENT AND SIDE-SHIFT CARRIAGE SERIAL NUMBERS

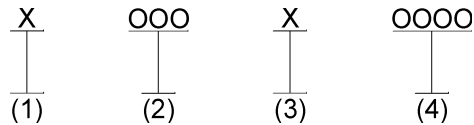

(1) and (2) The first letter and three numbers indicate the attachment unit code.

(3) The second letter indicates the plant of manufacture.

(4) The four or five digit number indicates the production sequence number.

For pending production sequence numbers contact your local dealer for Hyster lift trucks.

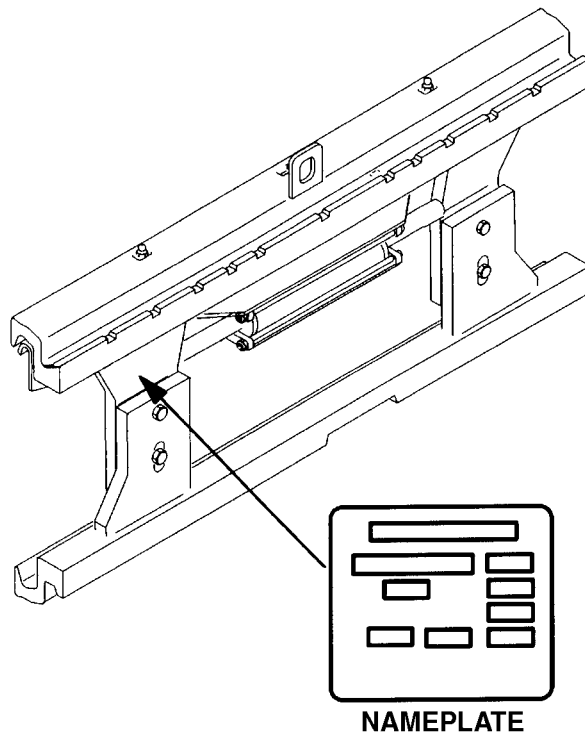

HP990003

Side-shift carriages and attachments have nameplates. Use the serial number found on the nameplate to identify the attachment.

Always refer to the group, serial, or part number when ordering service parts.

Modifications of attachments and side-shift carriages by SPED (Special Products Engineering Department) are identified by a model prefix code beginning with the letter "S". Contact your dealer for Hyster lift trucks for information on these assemblies.

PUBLICATIONS

Every new lift truck is provided with an OPERATING MANUAL. This manual has information that the operator must know for inspection and operation of the lift truck.

SERVICE MAINTENANCE MANUALS, which provide service and overhaul procedures, and PARTS MANUALS with complete replacement part identification, are available at a nominal fee from your Hyster dealer to assist users in effectively maintaining Hyster lift trucks in a safe, useful condition. See the list below for information on ordering specific publications for this model lift truck.

PUBLICATION	HYSTER PART NUMBER
Operating Manual	1534729
Service Manual (Complete)	1551322
Parts Manual	1551316

Please Click Here To Download The Complete Manual
Download Other Manuals
If Having Any Questions Feel Free To Contact us

admin@servicemanualbit.com