

# **PARTS MANUAL**

---

**ELECTRIC**

**E25XM2, E30XM2,  
E35XM2, E40XMS2  
(D114)**

CUSTOMER EDITION

---

***HYSTER***



**SECTIONS**

<b>1</b>	<b>FRAME</b>
<b>2</b>	<b>ELECTRICAL SYSTEM</b>
<b>3</b>	<b>DRIVE UNIT</b>
<b>4</b>	<b>STEERING SYSTEM</b>
<b>5</b>	<b>BRAKE/ACCELERATOR SYSTEM</b>
<b>6</b>	<b>HYDRAULIC SYSTEM</b>
<b>7</b>	<b>MAST-TWO STAGE LIMITED FREE-LIFT</b>
<b>8</b>	<b>MAST-THREE STAGE FULL FREE-LIFT</b>
<b>9</b>	<b>MAST-TWO STAGE FULL FREE-LIFT</b>
<b>10</b>	<b>OPTIONS</b>
<b>11</b>	<b>NUMERICAL INDEX</b>

This Parts Manual is divided into 11 major sections which are listed above. Quick reference to these sections can be made by placing the right thumb on the tab of the desired section, bending the book back and thumbing the pages to the corresponding tab.



**TABLE OF CONTENTS**

DESCRIPTION	PAGE
<b>A</b>	
ACCELERATOR .....	5-16
ACCELERATOR PEDAL.....	5-18
<b>B</b>	
BACK-UP ALARM .....	10-27
BATTERY CONNECTOR .....	2-26
BATTERY SLIDE AND ROLLER TRAY .....	10-18
BRAKE ASSEMBLY .....	5-6
BRAKE PEDAL LINKAGE .....	5-2
BRAKE/BACK-UP LIGHT 12 VOLT .....	10-20
<b>C</b>	
CARRIAGE	
THREE STAGE FULL FREE-LIFT .....	8-18
TWO STAGE FULL FREE-LIFT .....	9-16
TWO STAGE LIMITED FREE-LIFT.....	7-12
CONTACTOR .....	2-22
1A AND RB.....	2-20
CONTACTOR PANEL	
CONTACTOR HYDRAULIC .....	2-16
CONTROL .....	2-14
CONTACTOR STEERING .....	2-18
CONTROL PANEL	
CONTACTOR HYDRAULIC .....	2-10
TRANSISTOR HYDRAULIC .....	2-12
CONTROL VALVE	
FOUR FUNCTION .....	6-54
THREE FUNCTION .....	6-50
CONTROL VALVE ATTACHING PARTS.....	6-42
COUNTERWEIGHT .....	1-14
COVERS .....	1-6
COWL ELECTRICAL.....	2-24
<b>D</b>	
DIFFERENTIAL.....	3-6
DRIVE AND REAR LIGHTS .....	10-22
DRIVE AXLE .....	3-2
DRIVE MOTOR MOUNT .....	6-6
<b>E</b>	
E/EE/ES AND CRE/FRE INSTALLATION .....	3-8
ELECTRICAL SYSTEM	
CONTACTOR HYDRAULIC .....	2-2
TRANSISTOR HYDRAULIC .....	2-6

## TABLE OF CONTENTS (Continued)

DESCRIPTION	PAGE
<b>F</b>	
FORK	
THREE STAGE FULL FREE-LIFT .....	8-28
TWO STAGE FULL FREE-LIFT .....	9-27
TWO STAGE LIMITED FREE-LIFT .....	7-22
FRAME .....	1-2
FREE-LIFT	
THREE STAGE FULL FREE-LIFT .....	8-10
TWO STAGE FULL FREE-LIFT .....	9-8
FREE-LIFT CYLINDER	
THREE STAGE FULL FREE-LIFT .....	8-16
TWO STAGE FULL FREE-LIFT .....	9-14
FULL SUSPENSION SEAT	
SHEET 1 OF 2 .....	1-22
SHEET 2 OF 2 .....	1-24
<b>G</b>	
GEAR PUMP .....	4-14
OPTIONAL .....	4-16
<b>H</b>	
HAND LEVER .....	6-46
HEADER HOSE	
THREE STAGE FULL FREE-LIFT	
FOUR FUNCTION .....	8-26
THREE FUNCTION .....	8-24
TWO STAGE FULL FREE-LIFT	
FOUR FUNCTION .....	9-24
THREE FUNCTION .....	9-22
TWO STAGE LIMITED FREE-LIFT	
FOUR FUNCTION .....	7-20
THREE FUNCTION .....	7-18
HOOD .....	1-8
HYDRAULIC .....	6-2
HYDRAULIC MOTOR	
CLOSED CONSTRUCTION	
S/N PENDING PER ECN 73755 ⇒ .....	6-38
ECONOMY TRUCK WITH BWI	
⇒ D/B 01/2000 .....	6-24
D/B 01/2000 ⇒ .....	6-26
OPTIONAL	
⇒ S/N PENDING PER ECN 73755 .....	6-28
ECONOMY TRUCK WITHOUT BWI	
⇒ D/B 01/2000 .....	6-20
D/B 01/2000 ⇒ .....	6-22
OPEN CONSTRUCTION	
S/N PENDING PER ECN 73755 ⇒ .....	6-34
PREMIUM TRUCK	
CLOSED CONSTRUCTION	
⇒ S/N PENDING PER ECN 73755 .....	6-36
OPEN CONSTRUCTION .....	6-30
PREMIUM TRUCK OPEN CONSTRUCTION	

**TABLE OF CONTENTS (Continued)**

DESCRIPTION	PAGE
<b>H (continued)</b>	
OPTIONAL ⇒ S/N PENDING PER ECN 73755 .....	6-32
HYDRAULIC PUMP	
12 CC SINGLE GEAR PUMP .....	6-8
OPTIONAL .....	6-10
19 CC	
OPTIONAL .....	6-18
19 CC DOUBLE GEAR PUMP .....	6-14
LOW NOISE .....	6-16
OPTIONAL .....	6-12
HYDRAULIC TANK .....	6-58
<b>I</b>	
INNER MAST	
THREE STAGE FULL FREE-LIFT .....	8-6
TWO STAGE FULL FREE-LIFT .....	9-4
TWO STAGE LIMITED FREE-LIFT .....	7-4
INTEGRAL	
HYDRAULIC HOSES	
TWO STAGE FULL FREE-LIFT, THREE STAGE FULL FREE-LIFT .....	10-17
TWO STAGE LIMITED FREE-LIFT .....	10-16
INTEGRAL SIDE-SHIFT CARRIAGE	
TWO AND THREE STAGE FULL FREE-LIFT .....	10-12
TWO STAGE LIMITED FREE-LIFT .....	10-10
INTEGRAL SIDE-SHIFT CYLINDER .....	10-14
INTERMEDIATE MAST	
THREE STAGE FULL FREE-LIFT .....	8-4
<b>L</b>	
LABELS .....	1-27
LIFT	
TWO STAGE LIMITED FREE-LIFT .....	7-6
LIFT CYLINDER	
TWO STAGE LIMITED FREE-LIFT	
LEFT HAND .....	7-8
RIGHT HAND .....	7-10
LOAD BACKREST EXTENSION	
THREE STAGE FULL FREE-LIFT .....	8-20
TWO STAGE FULL FREE-LIFT .....	9-18
TWO STAGE LIMITED FREE-LIFT .....	7-14
<b>M</b>	
MAIN LIFT	
THREE STAGE FULL FREE-LIFT .....	8-8
TWO STAGE FULL FREE-LIFT .....	9-6
MAIN LIFT CYLINDER	
THREE STAGE FULL FREE-LIFT	
LEFT HAND .....	8-12
RIGHT HAND .....	8-14

**TABLE OF CONTENTS (Continued)**

DESCRIPTION	PAGE
<b>M</b> (continued)	
TWO STAGE FULL FREE-LIFT	
LEFT HAND .....	9-10
RIGHT HAND .....	9-12
MAST INSTALLATION	
THREE STAGE FULL FREE-LIFT .....	8-22
TWO STAGE FULL FREE-LIFT .....	9-20
TWO STAGE LIMITED FREE-LIFT .....	7-16
MASTER CYLINDER .....	5-4
<b>N</b>	
NON-SUSPENSION SEAT .....	1-16
<b>O</b>	
OUTER MAST	
THREE STAGE FULL FREE-LIFT .....	8-2
TWO STAGE FULL FREE-LIFT .....	9-2
TWO STAGE LIMITED FREE-LIFT .....	7-2
OVERHEAD GUARD .....	1-12
<b>P</b>	
PARK BRAKE	
LEVER ACTUATED .....	5-8
SEAT ACTUATED .....	5-14
PARK BRAKE LINKAGE	
SEAT ACTUATED .....	5-12
<b>S</b>	
SHIFT LEVER .....	4-6
SIDE-SHIFT CARRIAGE .....	10-6
SIDE-SHIFT CYLINDER .....	10-8
SPOT LIGHT .....	10-26
STEERING AXLE .....	4-22
STEERING CONTROL UNIT .....	4-8
STEERING CYLINDER .....	4-12
STEERING HYDRAULIC .....	4-10
STEERING MOTOR	
WITH BWI .....	4-18
WITHOUT BWI .....	4-20
STEERING POD .....	4-2
STROBE LIGHT .....	10-24
SUSPENSION SEAT .....	1-18
<b>T</b>	
TILT CYLINDER .....	6-40
TIRE AND WHEEL	
DRIVE WHEEL .....	10-4
STEER WHEEL .....	10-2
TRACTION MOTOR	
HIGH SPEED WITH BWI .....	3-10



**TABLE OF CONTENTS (Continued)**

DESCRIPTION	PAGE
<b>T (continued)</b>	
HIGH SPEED WITHOUT BWI .....	3-12
LOW SPEED WITH BWI.....	3-14
TRANSMISSION .....	3-4
<b>W</b>	
WIRE HARNESS	
CONTROL VALVE SWITCH .....	2-32
DASH .....	2-27
LIGHT .....	2-28
MAIN.....	2-30
REAR LIGHT	
⇒ S/N D114V-5262.....	10-28
S/N D114V-5263 ⇒.....	10-30

**ABBREVIATIONS QUICK REFERENCE SHEET**

Listed below are abbreviations used in parts manuals to denote the following expressions:

<b>TERM</b>	<b>DEFINITION</b>	<b>TERM</b>	<b>DEFINITION</b>
Amp	Amperes	FRE	Freezer Environment
AR	As Required	in.	inches
BDI	Battery Discharge Indicators	LPG	Liquefied Petroleum Gas
BWI	Brush Wear Indicator	MAP	Manifold Absolute Pressure
CE	Communicator End	mm	millimeters
CRE	Corrosive Environment	MSTS	Microprocessor Spark Timing System
D/B	Date Break	NPT	National Pipe Threads
dbA	Decibel "A" Scale	O/S	Oversize
DE	Drive End	PTO	Power Take Off
ECH	Empty Container Handler	RPM	Revolutions per Minute
ECH-3	Empty Container Handler - 3 High Stacking	S/N	Serial Number
ECH-4	Empty Container Handler - 4 High Stacking	TMM	Truck Management Module
ECH-5	Empty Container Handler - 5 High Stacking	UL Type D	Diesel-Powered Safety Rating
ECH-6	Empty Container Handler - 6 High Stacking	UL Type DS	Diesel-Powered Safety Rating
ECH-7	Empty Container Handler - 7 High Stacking	UL Type E	Battery-Powered Safety Rating
ECM	Electronic Control Module	UL Type EE	Battery-Powered Safety Rating
ECN	Engineering Change Notice	UL Type ES	Battery-Powered Safety Rating
EEPROM	Electrically Erasable Programmable Read Only Memory	UL Type G	Gasoline-Powered Safety Rating
EPROM	Electrically Programmable Read Only Memory	UL Type GS	Gasoline-Powered Safety Rating
		UL Type LP	Gas-Powered Safety Rating
		UL Type LPS	LP Gas-Powered Safety Rating
		U/S	Undersize
		UL	Underwriters Laboratory
		V	Volts

## HOW TO USE THE ILLUSTRATED PARTS MANUAL

This parts manual describes and illustrates assemblies, subassemblies, and detail parts needed for service replacement.

The different constructions are indicated by keys and footnotes. The callouts correspond to descriptions found on the next page.

**HYSTER** UNIT CODE D001 NORTH AMERICA 06/2001

**TABLE OF CONTENTS**

DESCRIPTION	PAGE
AIR INTAKE AND FILTER DIESEL (⇒ D/B 11/96 ⇒)	3-22
AIR INTAKE AND FILTER DIESEL (D/B 11/96 ⇒)	
AIR INTAKE AND FILTER GASOLINE AND LPG	
ALTERNATOR GASOLINE, LPG, AND DIESEL -	
ALTERNATOR TYPES GS, LPS, AND DS	
AUXILIARY FUNCTION TUBE TWO AND THREE STAGE FULL F	

**SECTION 13 NUMERICAL INDEX**

PART NO.	ITEM PAGE NO.	PART NO.	ITEM PAGE NO.	PART NO.	ITEM PAGE NO.	PART NO.	ITEM PAGE NO.
142	3-4 19	10-13	25	11-27	29	12-31	12
12445	3-32 19	10-17	6	11-31	25	16719	3-36 5
	3-34 1	10-27	11	11-32	37	16751	3-16 27
		11	11	8-4	29	16849	3-34 21
		-11	6	8-4	45		3-36 20
		-21	11	8-8	34	16863	3-26 17
		4	13	9-7	9	16865	3-6 18
		12	6	9-7	19		4-27 41
		17	17	9-11	9	16882	9-7 30
		9	10	9-11	17		9-11 27
		23	46	10-9	21		10-10 36
		27	46	10-9	28		10-13 32
		26	14	10-13	16		11-7 24
		28	14	11-7	19		11-9 17
		29	14				
		29	25				

**SECTIONS**

- 1
- 2
- 3
- 4
- 5
- 6
- 7
- 8
- 9
- 10
- 11

**TRANSMISSION HOUSING**  
⇒ S/N D001H-2628

KEY:  
A: Diesel  
B: Gasoline and LPG

ITEM	PART NO.	DESCRIPTION	QTY	A	B
		Transmission	1		1
	2022547	Transmission	1	1	
	2023329	Case	2	2	2
	2021670	Case	4	4	4
1	2023418	Bearing Cap	1	1	1
2	296426	Washer	2	2	2
3	296426	Bolt	4	4	4
4	293582	Cover	2	2	2
5	2021390	Cotter Pin	4	4	4
6	1371656	O-Ring	1	1	1
7	2021329	Plug	4	4	4
8	2021915	Plug	22	22	22
9	2021675	Housing	39	39	39
10	2021336	Pin	1	1	1
11	287960	Lockwasher	1	1	1
12	292682	Hydraulic Pump	8	8	8
13	- - -	Fig Figure 5-3	8	8	8
14	2021345	Gasket	1	1	1
15	214364	Bolt	1	1	1
16	296418	Washer	1	1	1
17	2021388	Temperature Switch	1	1	1
18	2021389	Breather	9	9	9
19	2021383	Dipstick	9	9	9
20	292515	Bolt	2	2	2
21	136892	Nut	3	3	3
22	292527	Bolt	3	3	3
23	292531	Capscrew	4	4	4
24	292683	Lockwasher	4	4	4
25	293637	Bolt	1	1	1
26	296420	Washer	1	1	1
	996403	Transmission Kit (Includes Item 7)	1	1	1
	996405	Transmission Kit (Includes Item 14)	1	1	1

This Parts Manual is divided into 11 major sections which are listed above. Quick reference can be made by placing the right thumb on the tab of the desired section, bending the pages to the corresponding tab.

© Copy Right Date HYSTER COMPANY See Service Manual for service procedures. 5-15

## HOW TO FIND THE DESIRED PART NUMBER

### WHEN THE PART NUMBER AND THE NEXT HIGHER ASSEMBLY IS NOT KNOWN:

1. Determine the function and application of the part required. Turn to the Sections Page. Choose the general area of reference most likely to include the part.
2. Turn to the section you chose. Use the Section Table of Contents to determine the assembly which would normally contain the part required. Then locate the part on the assembly breakdown page.

### WHEN THE PART NUMBER IS NOT KNOWN AND THE NEXT HIGHER ASSEMBLY IS KNOWN:

3. Determine the assembly the required part is used on. Turn to the Table of Contents on Page i.
4. Locate the assembly the required part is used on and turn to the page indicated for that assembly. Then locate the part on the assembly breakdown page.

### WHEN THE PART NUMBER IS KNOWN:

5. Use the Numerical Index on Page 11-1 to find the part number. Turn to the page listed and locate the part as indicated by the item number.

### GENERAL:

The assembly breakdowns include part numbers, descriptions, quantities required, keys and footnotes to help in selecting correct parts.

6. Five periods in the PART NO. column (. . . . .) indicate that the part is either *Not Serviced Separately* or there is a reference to another figure. A figure reference is denoted by a pointing hand followed by a figure number in the DESCRIPTION column (☞ Figure 10)
7. Keys are used to show two or more similar assemblies, RH and LH assembly parts, etc. Select the appropriate key, "A", "B", "C", "D", or "E" and the corresponding quantity column to find the required parts. Two periods in the QTY column (..) indicate that the part is not used for that assembly.
8. Indented descriptions under the DESCRIPTION column are used to indicate assemblies and subparts of assemblies. In the example on the

previous page, *BEARING CAP* (Item 2) is a subpart of the major assembly *CASE*.

9. Quantities shown are for one assembly. The quantities of the subpart *BEARING CAP* are indicated as two and two. This means two per *CASE* assembly.
10. Serial number breaks identify the most current parts information and are shown as follows:
  - ⇒ **S/N D001H-2628**  
Indicates last serial number affected.
  - S/N D001H-2629** ⇒  
Indicates the first serial number affected.
  - S/N D001H-1553** ⇔ **S/N D001H-3291**  
Indicates a range of serial numbers affected.

ECN numbers for pending serial numbers are shown to allow for the inclusion of the most current parts information and are identified as follows:

- ⇒ **S/N Pending Per ECN 63243**  
Indicates a pending serial number for last unit affected.
- S/N Pending Per ECN 63243** ⇒  
Indicates a pending serial number for first unit affected.

Date breaks are used to indicate when a change occurred but a subsequent serial number break was not recorded. This is an arbitrary date usually based on the ECN release and are identified as follows:

- ⇒ **D/B 3/00**  
Indicates that a change occurred sometime within that month for the item affected.
- D/B 3/00** ⇒  
Indicates that a change occurred sometime within that month for the item affected.
- D/B 3/00** ⇔ **D/B 4/00**  
Indicates a range of production dates of the item affected.

Contact your local dealer for Hyster lift trucks for serial number information for items with a ECN or a date break.

### ORDERING PARTS:

When ordering replacement parts, give the unit serial number, part number, name of part and quantity required.

For any further information on parts, service, or ordering, consult your local dealer for Hyster lift trucks.

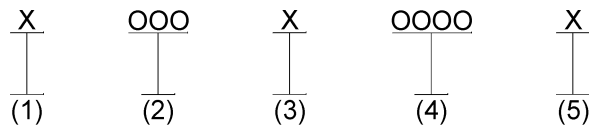
**IDENTIFICATION OF TRUCK SERIAL NUMBERS**

- (1) and (2) The first letter and three numbers indicate the truck unit code.
- (3) The second letter indicates the plant of manufacture.
- (4) The four or five digit number indicates the production sequence number of the truck.
- (5) The final letter indicates the year of manufacture starting with "A" in 1957 and 1980. The letters "I", "O", and "Q" will not be used.

For pending serial numbers contact your local dealer for Hyster lift trucks.

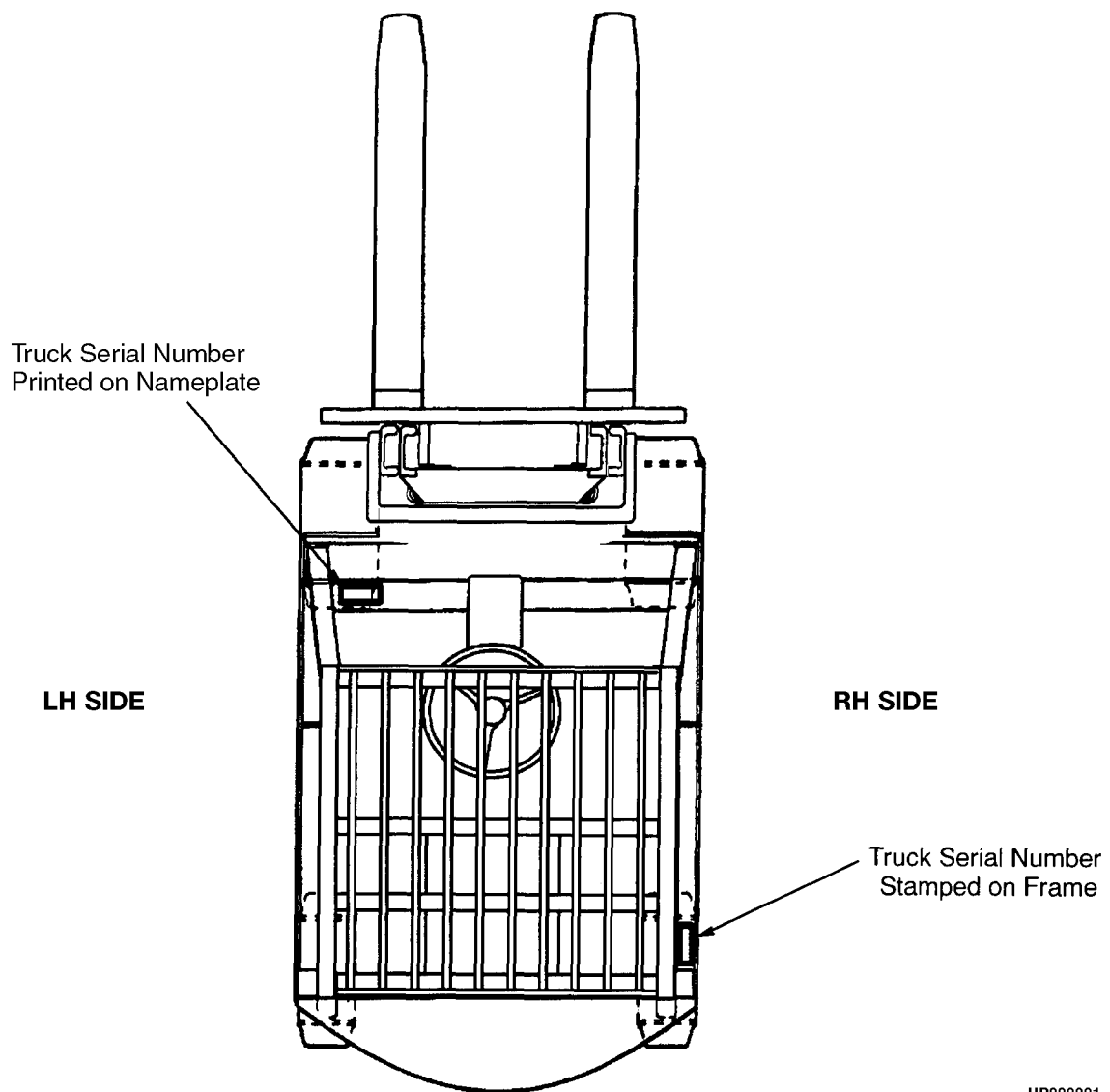

HP990001

Parts referred to in this book as right or left hand parts are in accordance with the illustration above.

## IDENTIFICATION OF MAST SERIAL NUMBERS

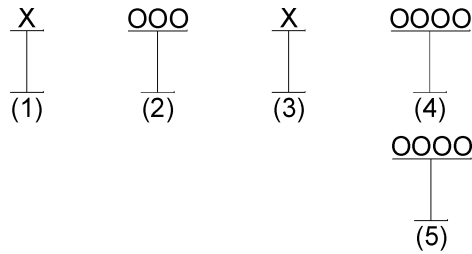

- (1) and (2) The first letter and number indicates the mast unit code.
- (3) The second letter indicates the plant of manufacture.
- (4) The four or five digit number indicates the production sequence number of the mast.
- (5) Carriage travel in millimeters stamped just below the serial number.

Mast Group identification consists of mast unit code (1) and (2) plus carriage travel (5).

For pending production sequence numbers contact your local dealer for Hyster lift trucks.

### LIFT EQUIPMENT IDENTIFICATION

1. Fork part number, capacity rating, plant code letter, and date of manufacture are stamped approximately six inches below the top of most forks.
2. The carriage group number is stamped on the right hand side of the top crossmember (pin type) or on the back of the right hand end of the bottom crossmember (hook type). A date code has two letters in line with or below the carriage group number.
3. The mast identification number has a unit code, a letter indicating the plant of manufacture, and a serial number. Underneath the production sequence number is a four digit number that indicates the carriage travel in millimeters.
4. Tilt and lift cylinder group numbers are stamped on the cylinder shell.

Always refer to the group, serial, or part number when ordering service parts.

Modification of masts and carriages by SPED (Special Products Engineering Department) are identified by a model prefix code beginning with the letter "S". contact your dealer for Hyster lift trucks for information on these assemblies.

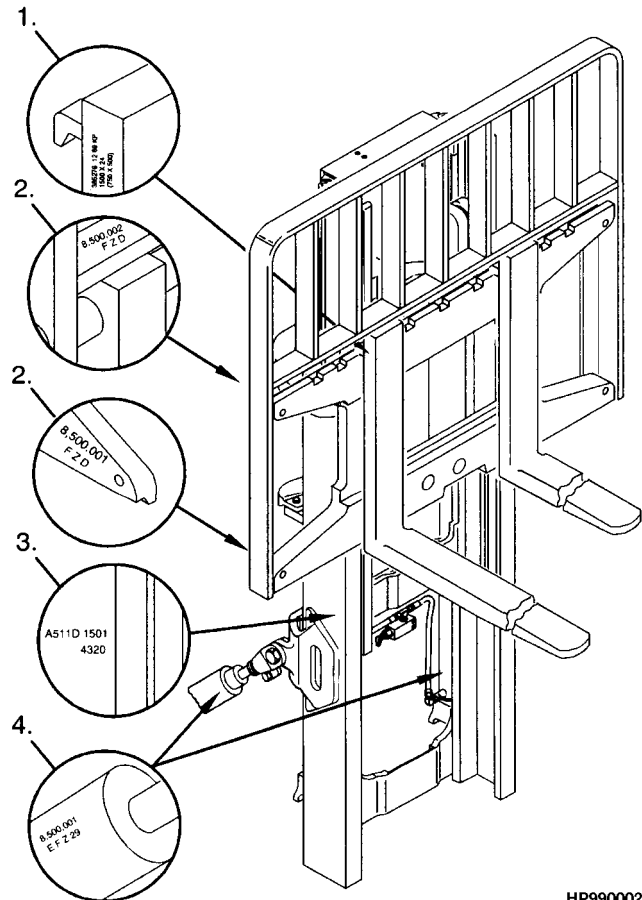

HP990002

## IDENTIFICATION OF ATTACHMENT AND SIDE-SHIFT CARRIAGE SERIAL NUMBERS

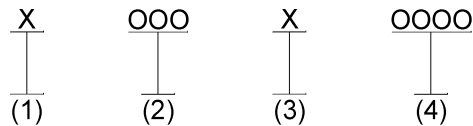

(1) and (2) The first letter and three numbers indicate the attachment unit code.

(3) The second letter indicates the plant of manufacture.

(4) The four or five digit number indicates the production sequence number.

For pending production sequence numbers contact your local dealer for Hyster lift trucks.

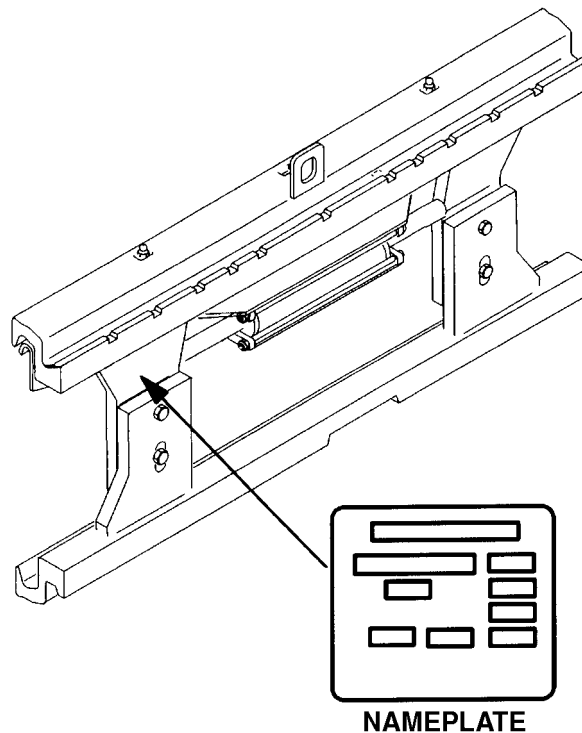

HP990003

Side-shift carriages and attachments have nameplates. Use the serial number found on the nameplate to identify the attachment.

Always refer to the group, serial, or part number when ordering service parts.

Modifications of attachments and side-shift carriages by SPED (Special Products Engineering Department) are identified by a model prefix code beginning with the letter "S". Contact your dealer for Hyster lift trucks for information on these assemblies.

**Please Click Here To Download The Complete Manual**  
**Download Other Manuals**  
**If Having Any Questions Feel Free To Contact us**

**[admin@servicemanualbit.com](mailto:admin@servicemanualbit.com)**