

# **PARTS MANUAL**

---

## **CHALLENGER**

**H360H, H400H, H400H-EC,  
H450H, H450H-EC  
(A214)**

**CUSTOMER EDITION**

---

# ***HYSTER***



**SECTIONS**

<b>1</b>	<b>FRAME</b>
<b>2</b>	<b>ENGINE ASSEMBLY</b>
<b>3</b>	<b>FUEL SYSTEM</b>
<b>4</b>	<b>ELECTRICAL SYSTEM</b>
<b>5</b>	<b>TRANSMISSION</b>
<b>6</b>	<b>DRIVE AXLE</b>
<b>7</b>	<b>STEERING SYSTEM</b>
<b>8</b>	<b>BRAKE SYSTEM</b>
<b>9</b>	<b>HYDRAULIC SYSTEM</b>
<b>10</b>	<b>MAST-TWO STAGE VISTA</b>
<b>11</b>	<b>MAST WITH EMPTY CONTAINER HANDLER</b>
<b>12</b>	<b>OPTIONS</b>
<b>13</b>	<b>NUMERICAL INDEX</b>

This Parts Manual is divided into 13 major sections which are listed above. Quick reference to these sections can be made by placing the right thumb on the tab of the desired section, bending the book back and thumbing the pages to the corresponding tab.



**TABLE OF CONTENTS**

DESCRIPTION	PAGE
<b>A</b>	
AIR FILTER	
EMPTY CONATAINER HANDLER	
TIER II ENGINE .....	2-8
FORK LIFT TRUCK	
TIER II ENGINE .....	2-6
TIER I ENGINE .....	2-4
AIR FILTER ASSEMBLY .....	2-10
AUXILIARY ATTACHMENTS	
EMPTY CONTAINER HANDLER .....	11-86
<b>B</b>	
BRAKE CHECK VALVE	
EMPTY CONTAINER HANDLER	
⇒S/N A214E-1572 .....	8-22
FORK LIFT TRUCK	
⇒S/N A214E-1572 .....	8-24
BRAKE COOLING SYSTEM	
ACCUMULATOR .....	9-72
EMPTY CONTAINER HANDLER	
⇒S/N A214E-1751 .....	9-64
S/N A214E-1752⇒ .....	9-66
FORK LIFT TRUCK	
⇒S/N A214E-1751 .....	9-68
S/N A214E-1752⇒ .....	9-70
BRAKE LINES	
EMPTY CONTAINER HANDLER	
⇒S/N A214E-1572 .....	8-2
S/N A214E-1573⇒ .....	8-4
FORK LIFT TRUCK	
⇒S/N A214E-1572 .....	8-8
S/N A214E-1573⇒ .....	8-10
BRAKE PEDAL LINKAGE	
EMPTY CONTAINER HANDLER .....	8-14
FORK LIFT TRUCK .....	8-18
BRAKE SYSTEM	
POWER BRAKE VALVE .....	8-26
<b>C</b>	
CARRIAGE	
HYDRAULIC SYSTEM	
TWO STAGE VISTA .....	10-30
TWO STAGE VISTA .....	10-26
WITH QUICK DISCONNECT	
TWO STAGE VISTA .....	10-28
CONTROL PANEL	
⇒S/N A214E-1806 .....	4-24
S/N A214E-1807⇒ .....	4-26
COOLING	
EMPTY CONATAINER HANDLER	
TIER II ENGINE .....	2-20

**TABLE OF CONTENTS (Continued)**

DESCRIPTION	PAGE
<b>C (continued)</b>	
FORK LIFT TRUCK	
TIER II ENGINE .....	2-16
TIER I ENGINE .....	2-12
COUNTERWEIGHTS .....	1-46
COVERS	
EMPTY CONTAINER HANDLER .....	1-26
FORK LIFT TRUCK .....	1-28
<b>D</b>	
DIFFERENTIAL ASSEMBLY .....	6-6
DOORS .....	1-24
DOUBLE HORIZONTAL TWIST LOCK HEAD ASSEMBLY	
CONTAINER HANDLING ATTACHMENT (572)	
S/N A214E-1807⇒ .....	11-38
DRIVE AXLE .....	6-2
<b>E</b>	
ELECTRICAL	
CHASSIS	
TIER I ENGINE .....	4-4
CHASSIS (TIER II ENGINE)	
SHEET 1 OF 4 .....	4-8
SHEET 2 OF 4 .....	4-10
SHEET 3 OF 4 .....	4-12
SHEET 4 OF 4 .....	4-16
ELECTRICAL SYSTEM	
SPREADER 572 AND 573	
S/N A214E-1807⇒ .....	11-70
SPREADER 575	
S/N A214E-1807⇒ .....	11-72
SPREADER 578	
S/N A214E-1807⇒ .....	11-74
ELECTRONIC FOOT PEDAL MOUNT	
TIER II ENGINE .....	3-10
EMPTY HANDLER	
EMPTY CONTAINER HANDLER	
S/N A214E-1807⇒ .....	11-28
ENGINE ASSEMBLY .....	2-2
ENGINE MOUNT .....	2-24
EXHAUST	
EMPTY CONTAINER HANDLER	
TIER I ENGINE .....	2-26
TIER II ENGINE .....	2-28
FORK LIFT TRUCK .....	2-30
EXTENSION CYLINDER	
EMPTY CONTAINER HANDLER	
⇒S/N A214E-1806 .....	11-62
S/N A214E-1807⇒ .....	11-64

**TABLE OF CONTENTS (Continued)**

DESCRIPTION	PAGE
<b>F</b>	
FENDERS	
EMPTY CONTAINER HANDLER.....	1-50
FLOOR PLATES AND COVERS	
EMPTY CONTAINER HANDLER.....	1-4
FORK LIFT TRUCK	
SHEET 1 OF 2 .....	1-8
SHEET 2 OF 2 .....	1-12
FORK	
HOOK TYPE.....	12-8
PIN TYPE.....	12-6
FORK POSITIONER	
SIDE-SHIFT CYLINDER - HOOK TYPE	
TWO STAGE VISTA .....	10-32
FUEL SYSTEM	
TIER I ENGINE.....	3-2
TIER II ENGINE.....	3-6
<b>G</b>	
GENERAL TRUCK.....	1-2
<b>H</b>	
HEADER HOSE	
EMPTY CONTAINER HANDLER	
⇒S/N A214E-1578.....	11-76
S/N A214E-1579⇔S/N PENDING PER ECN 68240 .....	11-78
S/N PENDING PER ECN 68240⇒ .....	11-82
TWO STAGE VISTA .....	10-20
HEATER .....	1-38
HEATER CONTROL.....	1-42
HOOD	
EMPTY CONTAINER HANDLER.....	1-32
FORK LIFT TRUCK .....	1-34
HYDRAULIC CONTROL	
⇒S/N A214E-1842Z .....	9-32
S/N A214E-1843Z⇒ .....	9-36
HYDRAULIC CONTROL VALVE	
ATTACHING PARTS.....	9-38
MAIN.....	9-40
HYDRAULIC DIRECTIONAL CONTROL VALVE	
EMPTY CONTAINER HANDLER.....	9-44
HYDRAULIC LINES	
AUXILIARY	
FORK LIFT TRUCK.....	9-29
CONTROL VALVE	
⇒S/N A214E-1806.....	9-22
SHEET 1 OF 2	
S/N A214E-1807⇒ .....	9-24
SHEET 2 OF 2 .....	9-26
LIFT	
FORK LIFT TRUCK.....	9-30
HYDRAULIC PILOT CONTROL SUPPLY VALVE	

## TABLE OF CONTENTS (Continued)

DESCRIPTION	PAGE
<b>H</b> (continued)	
EMPTY CONTAINER HANDLER.....	9-52
HYDRAULIC PILOT CONTROL VALVE EMPTY CONTAINER HANDLER.....	9-50
HYDRAULIC PUMP ⇒S/N A214E-1534 .....	9-56
S/N A214E-1535⇒ .....	9-58
HYDRAULIC RELIEF VALVE TILT EMPTY CONTAINER HANDLER .....	9-54
HYDRAULIC SOLENOID VALVE LIFT AND LOWERING INTERRUPT EMPTY CONTAINER HANDLER S/N PENDING PER ECN 99998-01⇒.....	9-48
HYDRAULIC SOLENOID VALVE ATTACHING PARTS LIFT AND LOWERING INTERRUPT EMPTY CONTAINER HANDLER S/N PENDING PER ECN 99998-01⇒.....	9-46
HYDRAULIC SUPPLY AND RETURN EMPTY CONATAINER HANDLER S/N A214E-1535⇒.....	9-6
EMPTY CONTAINER HANDLER ⇒S/N A214E-1534.....	9-4
FORK LIFT TRUCK S/N PENDING PER ECN 68204⇒ .....	9-14
⇒S/N PENDING PER ECN 68204 .....	9-10
HYDRAULIC SYSTEM EMPTY CONTAINER HANDLER SHEET 1 OF 2 ⇒S/N A214E-1806 .....	11-24
SHEET 2 OF 2 ⇒S/N A214E-1806 .....	11-26
SPREADER 572 S/N A214E-1807⇒.....	11-36
SPREADER 573 S/N A214E-1807⇒.....	11-40
SPREADER 575 S/N A214E-1807⇒.....	11-54
SPREADER 578 S/N A214E-1807⇒.....	11-44
HYDRAULIC TANK ⇒S/N A214E-1534 .....	9-60
S/N A214E-1535⇒ .....	9-62
<b>I</b>	
INNER MAST EMPTY CONTAINER HANDLER.....	11-6
TWO STAGE VISTA .....	10-6
INSTRUMENT PANEL SHEET 1 OF 2.....	4-18



**TABLE OF CONTENTS (Continued)**

DESCRIPTION	PAGE
I (continued)	
SHEET 2 OF 2 .....	4-22
L	
LABELS	
EXTERIOR	
EMPTY CONTAINER HANDLER .....	1-56
FORK LIFT TRUCK .....	1-58
INTERIOR .....	1-54
LIFT CYLINDER	
EMPTY CONTAINER HANDLER .....	11-16
H360-400H	
TWO STAGE VISTA .....	10-16
H450H	
TWO STAGE VISTA .....	10-18
LIFT CYLINDER ATTACHING PARTS	
EMPTY CONTAINER HANDLER .....	11-18
LIGHT CONTROLS .....	4-28
LIGHTS	
EMPTY CONTAINER HANDLER .....	4-30
FORK LIFT TRUCK .....	4-34
ROTATING BEACON .....	4-38
M	
MAIN LIFT	
EMPTY CONTAINER HANDLER	
⇒S/N A214E-1654 .....	11-8
S/N A214E-1655⇒ .....	11-12
TWO STAGE VISTA	
SHEET 1 OF 2 .....	10-10
SHEET 2 OF 2 .....	10-13
MAST INSTALLATION	
EMPTY CONTAINER HANDLER .....	11-88
TWO STAGE VISTA .....	10-24
O	
OIL COOLER AND ATTACHING PARTS	
EMPTY CONTAINER HANDLER	
TIER II ENGINE .....	9-18
FORK LIFT TRUCK	
TIER II ENGINE .....	9-20
OPERATOR COMPARTMENT	
WITH CAB	
SHEET 1 OF 3 .....	1-16
SHEET 2 OF 3 .....	1-18
SHEET 3 OF 3 .....	1-22
WITHOUT CAB .....	1-14
OUTER MAST	
EMPTY CONTAINER HANDLER .....	11-4
TWO STAGE VISTA .....	10-2

## TABLE OF CONTENTS (Continued)

DESCRIPTION	PAGE
<b>P</b>	
PARK BRAKE.....	6-10
PRE-CLEANER ASSEMBLY .....	2-11
<b>S</b>	
SEAT	
HIGH BACK	
KAB.....	1-52
SIDE-SHIFT CYLINDER	
EMPTY CONTAINER HANDLER	
⇒S/N A214E-1806.....	11-66
S/N A214E-1807⇒.....	11-68
SINGLE HORIZONTAL TWIST LOCK HEAD ASSEMBLY	
CONTAINER HANDLING ATTACHMENT (573)	
S/N A214E-1807⇒.....	11-42
SLAVE BEAM	
EMPTY CONTAINER HANDLER	
S/N A214E-1807⇒.....	11-34
SOLENOID VALVE	
TWO STAGE VISTA.....	10-34
SPRING LOADED HOOK HEAD ASSEMBLY	
CONTAINER HANDLING ATTACHMENT (575)	
S/N A214E-1807⇒.....	11-56
STEERING AXLE.....	7-18
STEERING CONTROL	
BLOCK VALVE	
⇒S/N PENDING PER ECN 68163 .....	7-16
STEERING CYLINDER.....	7-10
OPTIONAL.....	7-12
STEERING HOUSING AND CONTROL .....	7-2
STEERING HYDRAULICS	
EMPTY CONTAINER HANDLER.....	7-6
FORK LIFT TRUCK .....	7-8
STEERING PUMP	
⇒S/N PENDING PER ECN 68163 .....	7-14
<b>T</b>	
THROTTLE	
TIER I ENGINE.....	3-8
THROTTLE PEDAL	
ELECTRONIC	
TIER II ENGINE .....	3-16
TIER I ENGINE	
S/N PENDING PER ECN 68171-01⇒ .....	3-14
⇒S/N PENDING PER ECN 68171-01 .....	3-12
TILT CYLINDER	
EMPTY CONTAINER HANDLER.....	9-78
FORK LIFT TRUCK .....	9-80
HYDRAULIC SYSTEM	
EMPTY CONTAINER HANDLER.....	9-74
FORK LIFT TRUCK.....	9-76
TRANSMISSION	

**TABLE OF CONTENTS (Continued)**

DESCRIPTION	PAGE
<b>T (continued)</b>	
CLUTCH PACK	
SHEET 1 OF 3 .....	5-28
SHEET 2 OF 3 .....	5-32
SHEET 3 OF 3 .....	5-36
CONTROL VALVE	
⇒S/N A214E-1615.....	5-20
S/N A214E-1616⇒.....	5-24
CONTROL VALVE ATTACHING PARTS .....	5-18
INPUT SHAFT .....	5-14
SHIFT LEVER	
EMPTY CONTAINER HANDLER .....	5-40
TORQUE CONVERTER .....	5-17
TRANSMISSION ATTACHING PARTS	
SHEET 1 OF 3.....	5-2
SHEET 2 OF 3	
INCLUDES MOUNTING.....	5-6
SHEET 3 OF 3	
OIL FILTER.....	5-8
TRANSMISSION HYDRAULIC LINES	
⇒S/N A214E-1615 .....	5-10
S/N A214E-1616⇒ .....	5-12
TWIST LOCK CYLINDER	
EMPTY CONTAINER HANDLER	
⇒S/N A214E-1806.....	11-50
S/N A214E-1807⇒.....	11-52
<b>U</b>	
UNIVERSAL SHAFT .....	6-12
<b>V</b>	
VALVE ASSEMBLY	
END BEAM	
CONTAINER HANDLING ATTACHMENT	
S/N A214E-1807⇒ .....	11-60
SPREADER	
CONTAINER HANDLING ATTACHMENT	
S/N A214E-1807⇒ .....	11-58
SPREADER 575	
CONTAINER HANDLING ATTACHMENT	
S/N A214E-1807⇒ .....	11-59
VERTICAL END BEAM	
EMPTY CONTAINER HANDLER	
⇒S/N A214E-1806.....	11-22
VERTICAL TWIST LOCK HEAD ASSEMBLY	
CONTAINER HANDLING ATTACHMENT (578)	
S/N A214E-1807⇒.....	11-46

## TABLE OF CONTENTS (Continued)

DESCRIPTION	PAGE
<b>W</b>	
WEAR PADS	
CONTAINER HANDLING ATTACHMENT (570)	
S/N A214E-1807⇒.....	11-32
WEAR PLATES	
EMPTY CONTAINER HANDLER	
⇒S/N A214E-1806.....	11-20
WHEEL AND TIRE	
BIAS TIRE.....	12-2
RADIAL TIRE.....	12-3
SOLID TIRE	
SMOOTH.....	12-5
SOLID TIRE WITH TREAD.....	12-4
WINDSHIELD WASHER.....	1-44
WIRE HARNESS	
ATTACHMENT CONTROL	
⇒S/N A214E-1806.....	4-44
SHEET 1 OF 2	
⇒S/N A214E-1650.....	4-40
SHEET 2 OF 2	
⇒S/N A214E-1650.....	4-42
ATTACHMENT CONTROL SWITCH	
S/N A214E-1807⇒.....	4-46
ATTACHMENT LIGHTS	
S/N A214E-1807⇒.....	4-48
CAB	
⇒S/N A214E-1797.....	4-50
S/N A214E-1798⇒.....	4-52
CARRIAGE CONTROL SWITCH	
S/N PENDING PER ECN 59400-93⇒.....	4-54
CHASSIS	
EMPTY CONTAINER HANDLER.....	4-56
FORK LIFT TRUCK.....	4-58
EMPTY CONTAINER HANDLER	
⇒S/N A214E-1806.....	11-90
ENGINE	
⇒S/N A214E-1718.....	4-60
S/N A214E-1719⇒.....	4-62
FRONT END EQUIPMENT	
EMPTY CONTAINER HANDLER	
⇒S/N A214E-1806.....	4-64
S/N A214E-1807⇒.....	4-66
FORK LIFT TRUCK.....	4-68
FRONT LIGHTS.....	4-69
HOOK ATTACHMENT	
S/N A214E-1807⇒.....	11-93
HYDRAULIC	
EMPTY CONTAINER HANDLER	
S/N A214E-1651⇔S/N A214E-1806.....	4-70
S/N A214E-1807⇒.....	4-72
FORK LIFT TRUCK.....	4-74
MODULE	

**TABLE OF CONTENTS (Continued)**

DESCRIPTION	PAGE
<b>W</b> (continued)	
⇒S/N A214E-1797 .....	4-76
S/N A214E-1798⇒ .....	4-77
OPERATOR COMPARTMENT	
SHEET 1 OF 2 .....	4-78
SHEET 2 OF 2 .....	4-80
OPERATOR COMPARTMENT TO MAST LIGHT JUMPER .....	4-82
REAR LIGHT .....	4-83
ROTATING BEACON .....	4-84
STEERING POD .....	4-86
SWITCH	
WARNING .....	4-89
SWITCH LIGHTS .....	4-88
TRANSMISSION .....	4-90
⇒S/N A214E-1615 .....	4-92
S/N A214E-1616⇒ .....	4-94
TURN SIGNAL .....	4-96
TWIST LOCK	
S/N A214E-1807⇒ .....	11-92
WINDSHIELD WASHER .....	4-97
WORK LIGHTS .....	4-98
EMPTY CONTAINER HANDLER .....	4-99
FORK LIFT TRUCK .....	4-100
WORK LIGHTS EXTENSION	
FORK LIFT TRUCK .....	4-101

**ABBREVIATIONS QUICK REFERENCE SHEET**

Listed below are abbreviations used in parts manuals to denote the following expressions:

<b>TERM</b>	<b>DEFINITION</b>	<b>TERM</b>	<b>DEFINITION</b>
Amp	Amperes	FRE	Freezer Environment
AR	As Required	in.	inches
BDI	Battery Discharge Indicators	LPG	Liquefied Petroleum Gas
BWI	Brush Wear Indicator	MAP	Manifold Absolute Pressure
CE	Communicator End	mm	millimeters
CRE	Corrosive Environment	MSTS	Microprocessor Spark Timing System
D/B	Date Break	NPT	National Pipe Threads
dbA	Decibel "A" Scale	O/S	Oversize
DE	Drive End	PTO	Power Take Off
ECH	Empty Container Handler	RPM	Revolutions per Minute
ECH-3	Empty Container Handler - 3 High Stacking	S/N	Serial Number
ECH-4	Empty Container Handler - 4 High Stacking	TMM	Truck Management Module
ECH-5	Empty Container Handler - 5 High Stacking	UL Type D	Diesel-Powered Safety Rating
ECH-6	Empty Container Handler - 6 High Stacking	UL Type DS	Diesel-Powered Safety Rating
ECH-7	Empty Container Handler - 7 High Stacking	UL Type E	Battery-Powered Safety Rating
ECM	Electronic Control Module	UL Type EE	Battery-Powered Safety Rating
ECN	Engineering Change Notice	UL Type ES	Battery-Powered Safety Rating
EEPROM	Electrically Erasable Programmable Read Only Memory	UL Type G	Gasoline-Powered Safety Rating
EPROM	Electrically Programmable Read Only Memory	UL Type GS	Gasoline-Powered Safety Rating
		UL Type LP	Gas-Powered Safety Rating
		UL Type LPS	LP Gas-Powered Safety Rating
		U/S	Undersize
		UL	Underwriters Laboratory
		V	Volts

## HOW TO USE THE ILLUSTRATED PARTS MANUAL

This parts manual describes and illustrates assemblies, subassemblies, and detail parts needed for service replacement.

The different constructions are indicated by keys and footnotes. The callouts correspond to descriptions found on the the next page.

**HYSTER** UNIT CODE D001 NORTH AMERICA 06/2001

**TABLE OF CONTENTS**

DESCRIPTION	PAGE
AIR INTAKE AND FILTER DIESEL (⇒ D/B 11/96 ⇒)	3-22
AIR INTAKE AND FILTER DIESEL (D/B 11/96 ⇒)	
AIR INTAKE AND FILTER GASOLINE AND LPG	
ALTERNATOR GASOLINE, LPG, AND DIESEL	
ALTERNATOR TYPES GS, LPS, AND DS	
AUXILIARY FUNCTION TUBE TWO AND THREE STAGE FULL	

**SECTION 13 NUMERICAL INDEX**

PART NO.	ITEM PAGE NO.	PART NO.	ITEM PAGE NO.	PART NO.	ITEM PAGE NO.	PART NO.	ITEM PAGE NO.
142	3-4 19	10-13	25	11-27	29	12-31	12
12445	3-32 19	10-17	6	11-31	25	16719	3-35 5
	3-34 1	10-27	11	11-32	37	16751	3-16 27
		11-11	6	8-4	28	16849	3-34 21
		12-21	11	8-8	34	16863	3-36 20
		4	13	9-7	9	16865	3-6 17
		12	5	9-7	19	16882	4-27 41
		3	17	9-11	9		9-7 30
		9	10	9-11	17		9-11 27
		23	46	10-9	21		10-10 36
		27	46	10-9	28		10-13 32
		26	14	10-13	16		11-7 24
		28	14	11-7	19		11-9 17
		30	14				

**SECTIONS**

- 1
- 2
- 3
- 4
- 5
- 6
- 7
- 8
- 9
- 10
- 11

**TRANSMISSION HOUSING** ⇒ S/N D001H-2628

KEY:  
A: Diesel  
B: Gasoline and LPG

ITEM	PART NO.	DESCRIPTION	QTY	
			A	B
		Transmission	1	1
	2022547	Transmission	1	1
	2023229	Case	2	2
	2021670	Bearing Cap	4	4
1	2023418	Washer	4	4
2	296426	Bolt	1	1
3	293692	Washer	2	2
4	2021380	Coil Spring	4	4
5	1371656	Collar Pin	1	1
6	2021329	O-Ring	1	1
7	2021915	Plug	4	4
8	2021675	Housing	22	22
9	2021336	Pin	39	39
10	287860	Bolt	1	1
11	292682	Lockwasher	1	1
12		Hydraulic Pump	1	1
13		Figure 5-3	8	8
14	2021345	Gasket	1	1
15	214364	Bolt	8	8
16	296418	Washer	1	1
17	2021388	Temperature Switch	1	1
18	2021389	Breather	9	9
19	2021383	Dipstick	9	9
20	292515	Bolt	2	2
21	136692	Nut	3	3
22	292527	Bolt	3	2
23	292531	Lockwasher	4	4
24	292683	Lockwasher	4	4
25	293637	Bolt	1	1
26	296420	Washer	1	1
	996403	Transmission Kit (Includes Item 7)	1	1
	996405	Transmission Kit (Includes Item 14)	1	1

This Parts Manual is divided into 11 major sections which are listed above. Quick reference may be made by placing the right thumb on the tab of the desired section, bending the pages to the corresponding tab.

See Service Manual for service procedures

© Copy Right Date HYSTER COMPANY

5-15

## HOW TO FIND THE DESIRED PART NUMBER

### WHEN THE PART NUMBER AND THE NEXT HIGHER ASSEMBLY IS NOT KNOWN:

1. Determine the function and application of the part required. Turn to the Sections Page. Choose the general area of reference most likely to include the part.
2. Turn to the section you chose. Use the Section Table of Contents to determine the assembly which would normally contain the part required. Then locate the part on the assembly breakdown page.

### WHEN THE PART NUMBER IS NOT KNOWN AND THE NEXT HIGHER ASSEMBLY IS KNOWN:

3. Determine the assembly the required part is used on. Turn to the Table of Contents on Page i.
4. Locate the assembly the required part is used on and turn to the page indicated for that assembly. Then locate the part on the assembly breakdown page.

### WHEN THE PART NUMBER IS KNOWN:

5. Use the Numerical Index on Page 13-1 to find the part number. Turn to the page listed and locate the part as indicated by the item number.

### GENERAL:

The assembly breakdowns include part numbers, descriptions, quantities required, keys and footnotes to help in selecting correct parts.

6. Five periods in the PART NO. column (. . . . .) indicate that the part is either *Not Serviced Separately* or there is a reference to another figure. A figure reference is denoted by a pointing hand followed by a figure number in the DESCRIPTION column (☞ Figure 10)
7. Keys are used to show two or more similar assemblies, RH and LH assembly parts, etc. Select the appropriate key, "A", "B", "C", "D", or "E" and the corresponding quantity column to find the required parts. Two periods in the QTY column (..) indicate that the part is not used for that assembly.
8. Indented descriptions under the DESCRIPTION column are used to indicate assemblies and subparts of assemblies. In the example on the

previous page, *BEARING CAP* (Item 2) is a subpart of the major assembly *CASE*.

9. Quantities shown are for one assembly. The quantities of the subpart *BEARING CAP* are indicated as two and two. This means two per *CASE* assembly.
10. Serial number breaks identify the most current parts information and are shown as follows:
  - ⇒ **S/N D001H-2628**  
Indicates last serial number affected.
  - S/N D001H-2629** ⇒  
Indicates the first serial number affected.
  - S/N D001H-1553** ⇔ **S/N D001H-3291**  
Indicates a range of serial numbers affected.

ECN numbers for pending serial numbers are shown to allow for the inclusion of the most current parts information and are identified as follows:

- ⇒ **S/N Pending Per ECN 63243**  
Indicates a pending serial number for last unit affected.
- S/N Pending Per ECN 63243** ⇒  
Indicates a pending serial number for first unit affected.

Date breaks are used to indicate when a change occurred but a subsequent serial number break was not recorded. This is an arbitrary date usually based on the ECN release and are identified as follows:

- ⇒ **D/B 3/00**  
Indicates that a change occurred sometime within that month for the item affected.
- D/B 3/00** ⇒  
Indicates that a change occurred sometime within that month for the item affected.
- D/B 3/00** ⇔ **D/B 4/00**  
Indicates a range of production dates of the item affected.

Contact your local dealer for Hyster lift trucks for serial number information for items with a ECN or a date break.

### ORDERING PARTS:

When ordering replacement parts, give the unit serial number, part number, name of part and quantity required.

For any further information on parts, service, or ordering, consult your local dealer for Hyster lift trucks.

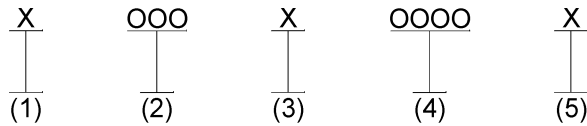

**IDENTIFICATION OF TRUCK SERIAL NUMBERS**

- (1) and (2) The first letter and three numbers indicate the truck unit code.
- (3) The second letter indicates the plant of manufacture.
- (4) The four or five digit number indicates the production sequence number of the truck.
- (5) The final letter indicates the year of manufacture starting with "A" in 1957 and 1980. The letters "I", "O", and "Q" will not be used.

For pending serial numbers contact your local dealer for Hyster lift trucks.

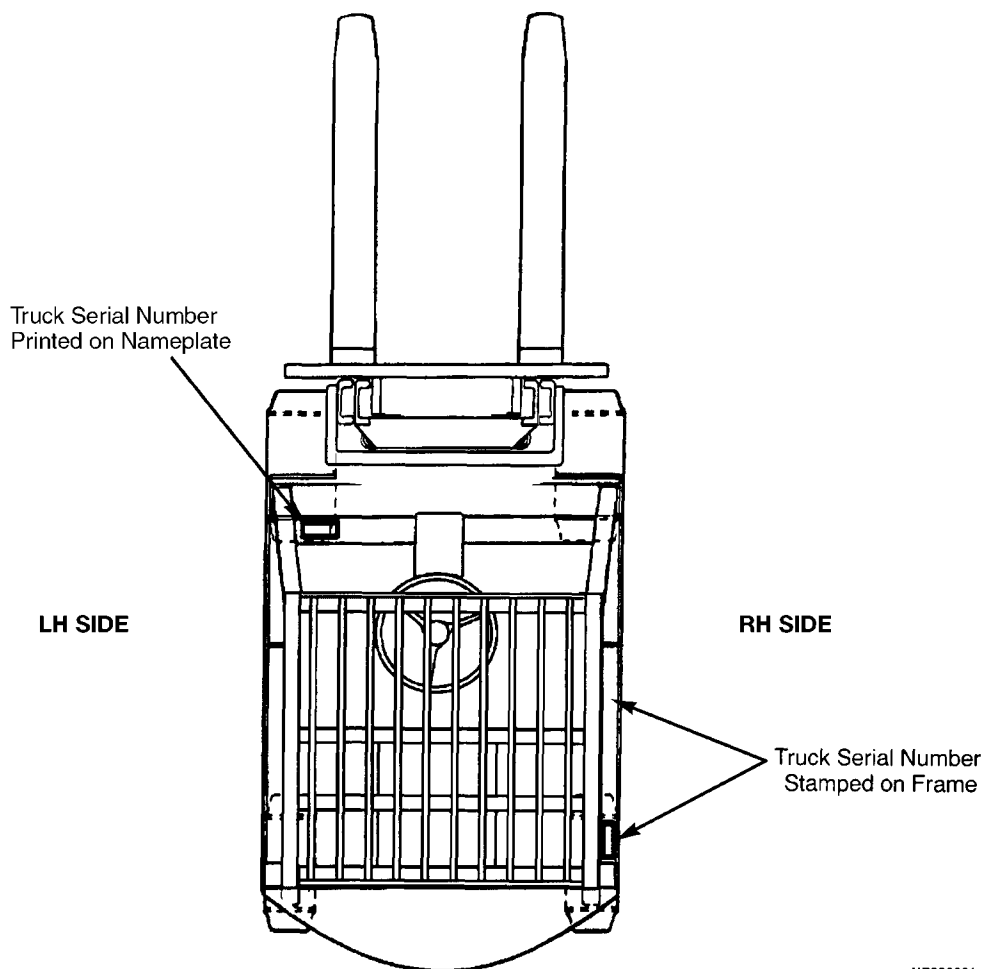

HP990001

Parts referred to in this book as right or left hand parts are in accordance with the illustration above.

## IDENTIFICATION OF MAST SERIAL NUMBERS

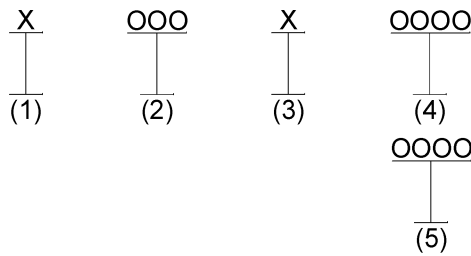

- (1) and (2) The first letter and number indicates the mast unit code.
- (3) The second letter indicates the plant of manufacture.
- (4) The four or five digit number indicates the production sequence number of the mast.
- (5) Carriage travel in millimeters stamped just below the serial number.

Mast Group identification consists of mast unit code (1) and (2) plus carriage travel (5).

For pending production sequence numbers contact your local dealer for Hyster lift trucks.

### LIFT EQUIPMENT IDENTIFICATION

1. Fork part number, capacity rating, plant code letter, and date of manufacture are stamped approximately six inches below the top of most forks.
2. The carriage group number is stamped on the right hand side of the top crossmember (pin type) or on the back of the right hand end of the bottom crossmember (hook type). A date code has two letters in line with or below the carriage group number.
3. The mast identification number has a unit code, a letter indicating the plant of manufacture, and a serial number. Underneath the production sequence number is a four digit number that indicates the carriage travel in millimeters.
4. Tilt and lift cylinder group numbers are stamped on the cylinder shell.

Always refer to the group, serial, or part number when ordering service parts.

Modification of masts and carriages by SPED (Special Products Engineering Department) are identified by a model prefix code beginning with the letter "S". contact your dealer for Hyster lift trucks for information on these assemblies.

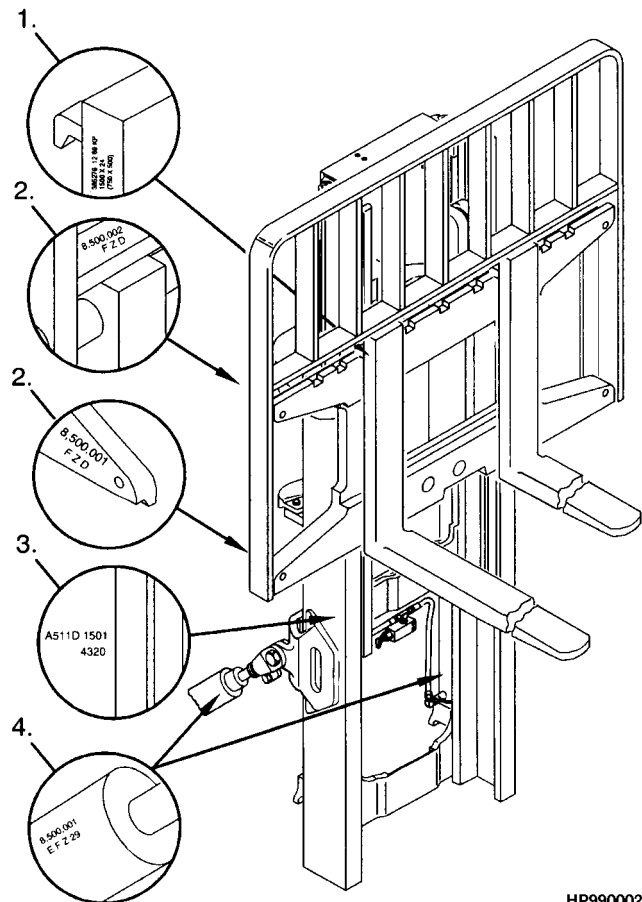

HP990002

## IDENTIFICATION OF ATTACHMENT AND SIDE-SHIFT CARRIAGE SERIAL NUMBERS

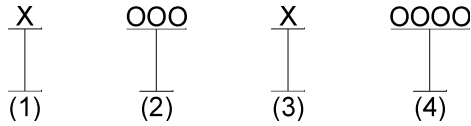

(1) and (2) The first letter and three numbers indicate the attachment unit code.

(3) The second letter indicates the plant of manufacture.

(4) The four or five digit number indicates the production sequence number.

For pending production sequence numbers contact your local dealer for Hyster lift trucks.

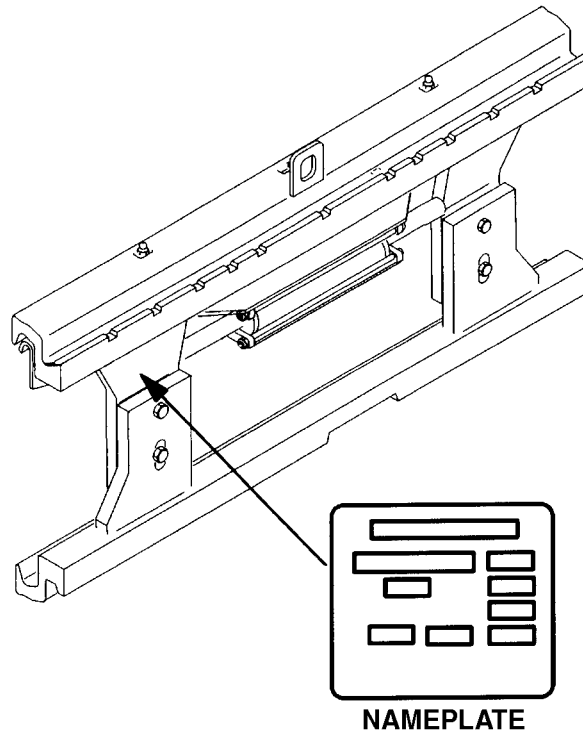

HP990003

Side-shift carriages and attachments have nameplates. Use the serial number found on the nameplate to identify the attachment.

Always refer to the group, serial, or part number when ordering service parts.

Modifications of attachments and side-shift carriages by SPED (Special Products Engineering Department) are identified by a model prefix code beginning with the letter "S". Contact your dealer for Hyster lift trucks for information on these assemblies.

---

**PUBLICATIONS**

Every new lift truck is provided with an OPERATING MANUAL. This manual has information that the operator must know for inspection and operation of the lift truck.

SERVICE MAINTENANCE MANUALS, which provide service and overhaul procedures, and PARTS MANUALS with complete replacement part identification, are available at a nominal fee from your Hyster dealer to assist users in effectively maintaining Hyster lift trucks in a safe, useful condition. See the list below for information on ordering specific publications for this model lift truck.

---

<b>PUBLICATION</b>	<b>HYSTER PART NUMBER</b>
<b>Operating Manual</b> .....	897997
<b>Service Manual (Complete)</b> .....	1452607
<b>Parts Manual</b> .....	897998

**1**

**FRAME**



**SECTION 1**  
**FRAME**

<b>DESCRIPTION</b>	<b>PAGE</b>
COUNTERWEIGHTS .....	1-46
COVERS	
EMPTY CONTAINER HANDLER.....	1-26
FORK LIFT TRUCK .....	1-28
DOORS .....	1-24
FENDERS	
EMPTY CONTAINER HANDLER.....	1-50
FLOOR PLATES AND COVERS	
EMPTY CONTAINER HANDLER.....	1-4
FORK LIFT TRUCK	
SHEET 1 OF 2 .....	1-8
SHEET 2 OF 2 .....	1-12
GENERAL TRUCK .....	1-2
HEATER .....	1-38
HEATER CONTROL.....	1-42
HOOD	
EMPTY CONTAINER HANDLER.....	1-32
FORK LIFT TRUCK .....	1-34
LABELS	
EXTERIOR	
EMPTY CONTAINER HANDLER .....	1-56
FORK LIFT TRUCK.....	1-58
INTERIOR.....	1-54
OPERATOR COMPARTMENT	
WITH CAB	
SHEET 1 OF 3 .....	1-16
SHEET 2 OF 3 .....	1-18
SHEET 3 OF 3 .....	1-22
WITHOUT CAB.....	1-14
SEAT	
HIGH BACK	
KAB .....	1-52
WINDSHIELD WASHER .....	1-44

## GENERAL TRUCK (Figure 1-1)

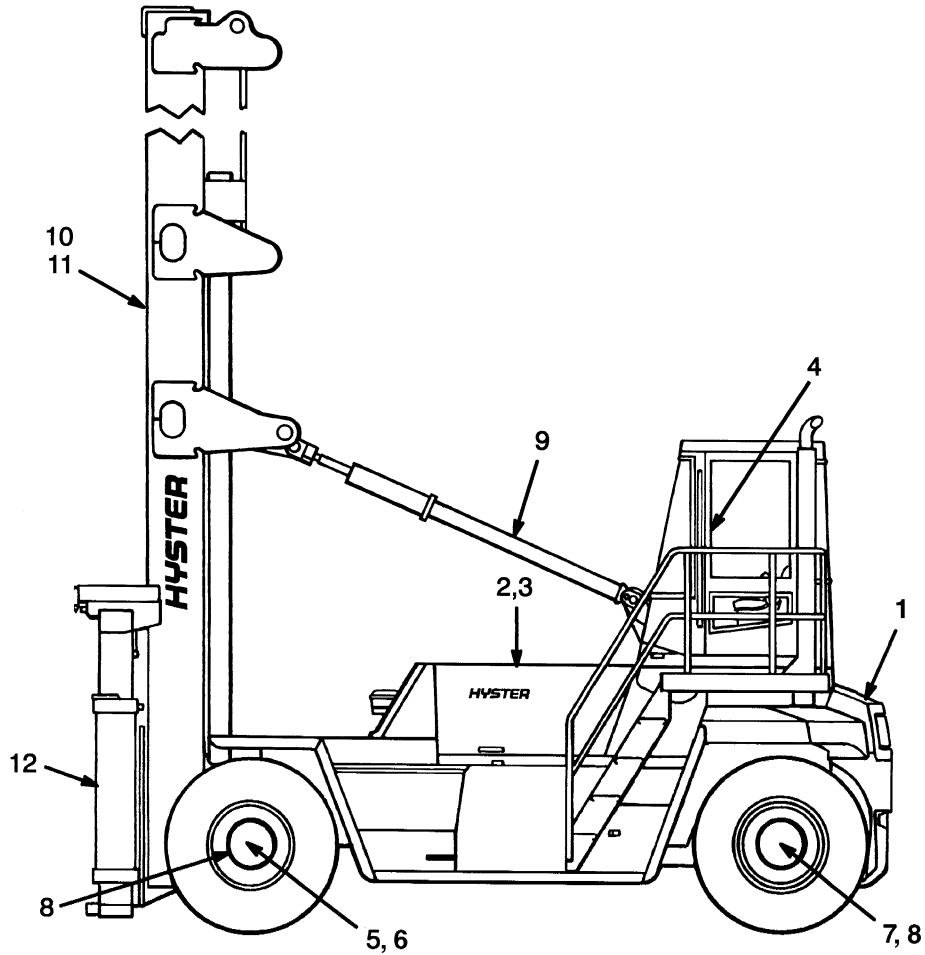

HP990033

ITEM	PART NO.	DESCRIPTION	QTY
1	.....	Counterweights (☞ Figure 1-17) .....	1
2	.....	Air Filter (☞ Figure 2-2) .....	1
3	.....	Fuel System (☞ Figure 3-1) .....	1
4	.....	Electrical System (☞ Figure 4-1) .....	1
5	.....	Transmission (☞ Figure 5-1) .....	1
6	.....	Drive Axle (☞ Figure 6-1) .....	1
7	.....	Steering System (☞ Figure 7-2) .....	1
8	.....	Brake System (☞ Figure 8-1) .....	1
9	.....	Hydraulic System (☞ Figure 9-1) .....	1
10	.....	Mast-Two Stage Limited Free-Lift (☞ Figure 10-1) .....	1
11	.....	Mast-Empty Container Handler (☞ Figure 11-1) .....	1
12	.....	Forks (☞ Figure 12-5) .....	1



**Please Click Here To Download The Complete Manual**  
**Download Other Manuals**  
**If Having Any Questions Feel Free To Contact us**

**[admin@servicemanualbit.com](mailto:admin@servicemanualbit.com)**