

PARTS MANUAL

**ELECTRIC
A20-25-30XL**

(A203)

CUSTOMER EDITION

HYSTER

ILLUSTRATED CONTENTS

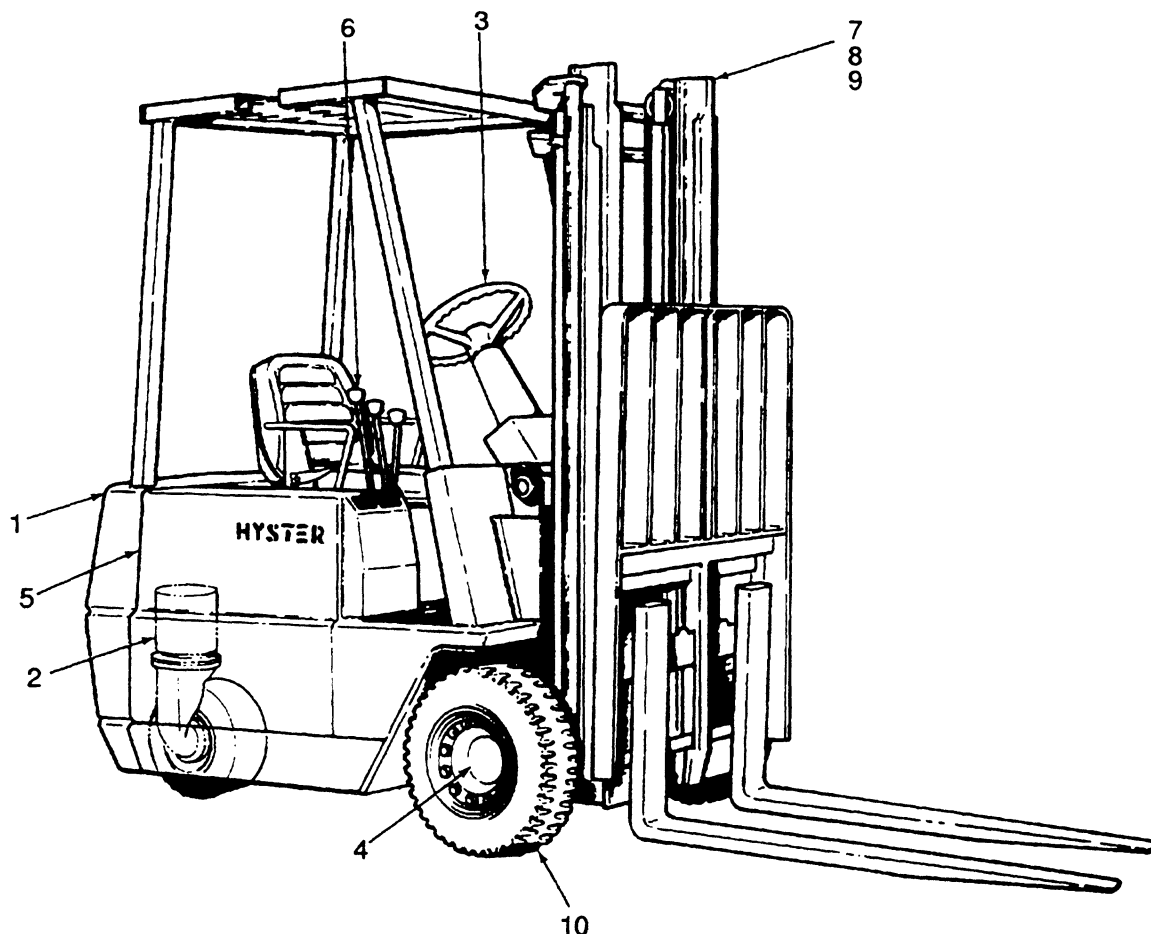

REF	SECTION	PAGE
1	FRAME	Page 3
2	MASTER DRIVE UNIT	Page 13
3	STEERING	Page 23
4	BRAKE	Page 33
5	ELECTRICAL SYSTEM	Page 43
6	HYDRAULIC SYSTEM	Page 57
7	TWO-STAGE LIMITED FREE LIFT MAST	Page 73
8	THREE-STAGE FULL FREE LIFT MAST	Page 83
9	TWO-STAGE FULL FREE LIFT MAST	Page 97
10	OPTIONAL EQUIPMENT	Page 111
11	NUMERICAL INDEX	Page 135

TABLE OF CONTENTS

DESCRIPTION	PAGE
A	
ACCELERATOR (Figure 22)	Page 40
ACCELERATOR PEDAL (Figure 23)	Page 41
B	
BATTERY DISCHARGE INDICATOR (Figure 32)	Page 55
BRAKE DRUM (Figure 24)	Page 42
BRAKE (Figure 18)	Page 36
BRAKE LINES (Figure 17)	Page 34
BYPASS CONTACTOR (Figure 29)	Page 52
C	
CARRIAGE (Figure 47) TWO STAGE LIMITED FREE LIFT	Page 81
CARRIAGE (Figure 55) THREE STAGE FULL FREE LIFT	Page 96
CARRIAGE (Figure 63) TWO STAGE FULL FREE LIFT	Page 109
CONTACTOR (Figure 28) FORWARD/REVERSE	Page 50
CONTROL PANEL (Figure 26)	Page 46
CONTROL VALVE (Figure 36) LAST USED ON S/N PENDING PER ECN 59123	Page 64
CONTROL VALVE (Figure 37) FIRST USED ON S/N PENDING PER ECN 59123	Page 66
E	
ELECTRICAL SYSTEM (Figure 25)	Page 44
F	
FIRE EXTINGUISHER (Figure 73)	Page 126
FORKS (Figure 65)	Page 114
FRAME (Figure 2)	Page 4

TABLE OF CONTENTS (CONTINUED)

<u>DESCRIPTION</u>	<u>PAGE</u>
F	
FREE-LIFT CYLINDER (Figure 54) THREE STAGE FULL FREE LIFT	Page 95
FREE-LIFT CYLINDER (Figure 62) TWO STAGE FULL FREE LIFT	Page 108
FREE-LIFT (Figure 52) THREE STAGE FULL FREE LIFT	Page 92
FREE-LIFT (Figure 59) TWO STAGE FULL FREE LIFT	Page 104
H	
HAND LEVER (Figure 34)	Page 60
HAND PUMP (Figure 14)	Page 29
HEADER HOSE (Figure 69) TWO STAGE LIMITED FREE LIFT	Page 119
HEADER HOSE (Figure 70) THREE STAGE FULL FREE LIFT	Page 121
HEADER HOSE (Figure 71) TWO STAGE FULL FREE LIFT	Page 123
HYDRAULIC FILTER (Figure 40) FIRST USED ON S/N A203A-2284	Page 70
HYDRAULIC MOTOR (Figure 15)	Page 30
HYDRAULIC MOTOR (Figure 42)	Page 72
HYDRAULIC OIL FILTER (Figure 39) LAST USED ON S/N A203A-2283	Page 69
HYDRAULIC PUMP (Figure 41)	Page 70
HYDRAULIC SYSTEM (Figure 33)	Page 58
I	
INNER MAST (Figure 44) TWO STAGE LIMITED FREE LIFT	Page 76
INNER MAST (Figure 50) THREE STAGE FULL FREE LIFT	Page 88
INNER MAST (Figure 57) TWO STAGE FULL FREE LIFT	Page 100

TABLE OF CONTENTS (CONTINUED)

DESCRIPTION	PAGE
I	
INTERMEDIATE MAST (Figure 49) THREE STAGE FULL FREE LIFT	Page 86
L	
LABELS & PAINT (Figure 3)	Page 6
LIFT CYLINDER (Figure 46) TWO STAGE LIMITED FREE LIFT	Page 80
LIFT (Figure 45) TWO STAGE LIMITED FREE LIFT	Page 78
LIGHTS (Figure 74)	Page 127
LOAD BACKREST EXTENSION (Figure 6)	Page 11
M	
MAIN LIFT CYLINDER (Figure 53) THREE STAGE FULL FREE LIFT	Page 94
MAIN LIFT CYLINDER (Figure 60) LEFT HAND TWO STAGE FULL FREE LIFT	Page 106
MAIN LIFT CYLINDER (Figure 61) RIGHT HAND TWO STAGE FULL FREE LIFT	Page 107
MAIN LIFT (Figure 51) THREE STAGE FULL FREE LIFT	Page 90
MAIN LIFT (Figure 58) TWO STAGE FULL FREE LIFT	Page 102
MASTER CYLINDER (Figure 19) LAST USED ON S/N A203A-3892	Page 37
MASTER CYLINDER (Figure 20) FIRST USED ON S/N A203A-3893	Page 38
MASTER DRIVE UNIT (Figure 7)	Page 14
MASTER DRIVE UNIT (Figure 8) SPETH: LAST USED ON S/N A203A-4936	Page 16
MASTER DRIVE UNIT (Figure 9) HURTH: FIRST USED ON S/N A203A-4937	Page 18

TABLE OF CONTENTS (CONTINUED)

<u>DESCRIPTION</u>	<u>PAGE</u>
O	
OUTER MAST (Figure 43) TWO STAGE LIMITED FREE LIFT	Page 74
OUTER MAST (Figure 48) THREE STAGE FULL FREE LIFT	Page 84
OUTER MAST (Figure 56) TWO STAGE FULL FREE LIFT	Page 98
OVERHEAD GUARD (Figure 5)	Page 10
P	
PARK BRAKE (Figure 21)	Page 39
PUMP CONTACTOR (Figure 30)	Page 53
S	
SCR CONTROL (Figure 27)	Page 48
SEAT (Figure 4)	Page 8
SIDESHIFT CARRIAGE (Figure 64) EARLY PRODUCTION	Page 112
SIDESHIFT CARRIAGE (Figure 67) LATE PRODUCTION	Page 116
SIDESHIFT CYLINDER (Figure 66) EARLY PRODUCTION	Page 115
SIDESHIFT CYLINDER (Figure 68) LATE PRODUCTION	Page 118
STEERING COLUMN (Figure 11)	Page 24
STEERING CONTACTOR (Figure 31)	Page 54
STEERING LINES (Figure 12)	Page 26
STEERING MOTOR (Figure 13)	Page 28
STEERING PUMP (Figure 16)	Page 31
STROBE LIGHT (Figure 75) MEDIUM INTENSITY	Page 129
STROBE LIGHT (Figure 76) HIGH INTENSITY	Page 131

TABLE OF CONTENTS (CONTINUED)

DESCRIPTION **PAGE**

T

TILT CYLINDER (Figure 38)	Page 68
TIRE & WHEEL (Figure 72)	Page 125
TRACTION MOTOR (Figure 10)	Page 20

V

VALVE ATTACHING PARTS (Figure 35)	Page 62
---	---------

WHEN THE PART NUMBER AND THE NEXT HIGHER ASSEMBLY IS NOT KNOWN:

1. Determine the function and application of the part required. Turn to the Illustrated Contents page immediately behind the front cover, and select the most appropriate area.
2. Use the Section Index to determine the assembly which would normally contain the part required. Proceed then to locate the part on the assembly breakdown page.

WHEN THE PART NUMBER IS NOT KNOWN AND THE NEXT HIGHER ASSEMBLY IS KNOWN:

3. Determine the assembly the required part is used on. Turn to the Table of Contents pages immediately following the Illustrated Contents.
4. Locate the assembly the required part is used on and turn to the page indicated for that assembly. Proceed then to locate the part on the assembly breakdown page.

WHEN THE PART NUMBER IS KNOWN:

5. Use the Numerical Index to find the part number. Turn to the Figure listed and locate the part as indicated by the reference number.

GENERAL:

The Assembly Breakdowns include part numbers, description, quantities required, keys and footnotes to help in selecting the correct parts.

6. Keys are used to show effective serial numbers for two or more similar assemblies, RH and LH assembly parts, etc. Select the appropriate key, "A", "B", "C", or "D" and the corresponding quantity column to find the required parts.
7. Indented descriptions under "Name of Part" are used to indicate subparts of assemblies. A major assembly is not indented. Parts under the first, second, or third indent are sub-parts of the major assembly shown above them.
8. Quantities shown are for one assembly. Note that two assemblies are shown, but the quantities of the subparts are indicated as three and three. This means three per assembly.
9. Engineering Change Notice (ECN) numbers for pending serial numbers are shown to allow for the inclusion of the most current parts information. Contact your local Dealer for Hyster Lift Trucks for serial number information listed by ECN number.

ORDERING PARTS:

When ordering replacement parts, give the unit serial number, part number, name of part and quantity required.

For any further information on parts, service, or ordering, consult your local Dealer for Hyster Lift Trucks.

UNIT IDENTIFICATION UNIT S/N

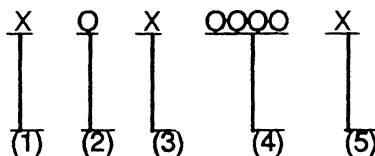

- (1) & (2) The first letter and number denote the design series and model of the unit
- (3) The second letter denotes the Plant at which the unit was manufactured
- (4) The number series denotes the serial number of the unit
- (5) The final letter denotes the year of manufacture starting with "A" in 1957 and 1980 The letters "I", "O", and "Q" will not be used

For pending serial numbers contact your local Hyster Dealer

Parts referred to in this book as right or left hand parts are in accordance with the illustration below

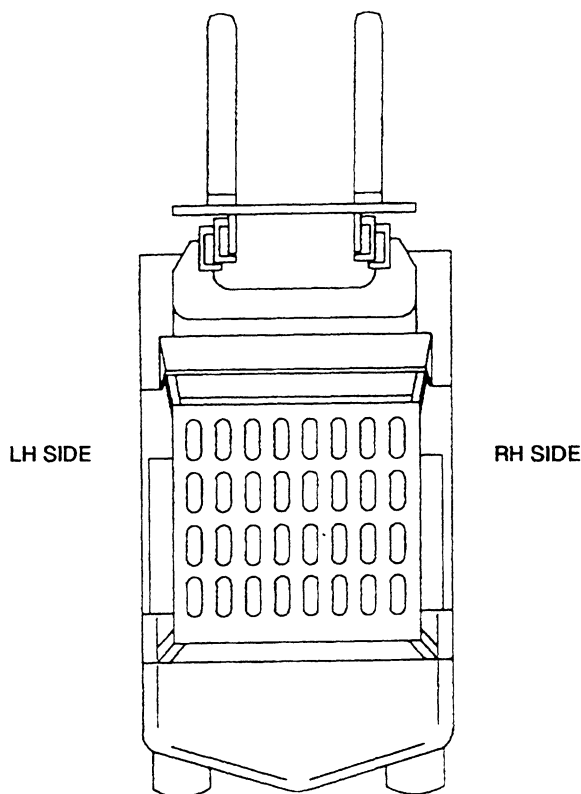

LIFT EQUIPMENT IDENTIFICATION

1. Mast group numbers and total lift heights are stamped on the right hand outer mast approximately four feet from the bottom of the fork. The group numbers include the inner and outer masts, lift cylinder, lift chain and bleeder hoses or pipes.
2. The carriage and tilt cylinder numbers are located as shown. Lift cylinder numbers are stamped on the cylinder shell near the bleeder screw or on the chain anchor. Fork part number, capacity rating, plant code letter and date of manufacture are stamped approximately six inches below the top RH side of forks. Always refer to these group and part numbers when ordering service parts.

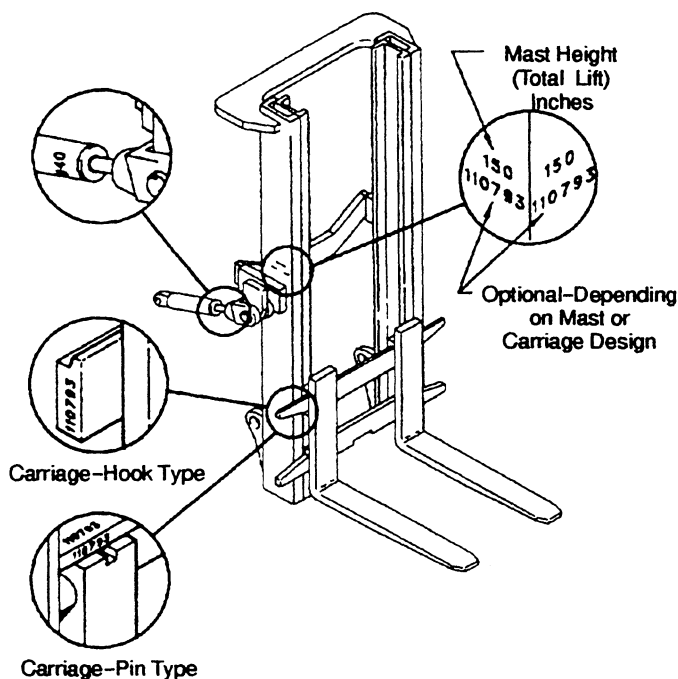

Please Click Here To Download The Complete Manual
Download Other Manuals
If Having Any Questions Feel Free To Contact us

admin@servicemanualbit.com